

DISCLAIMER: This standard is governed by the Texas Engineering Practices Act. No warranty of any kind is made by TxDOT for any purpose whatsoever. TxDOT assumes no responsibility for the condition of this standard or for incorrect formats or for incorrect results or damages resulting from its use.

DATE: FILE:

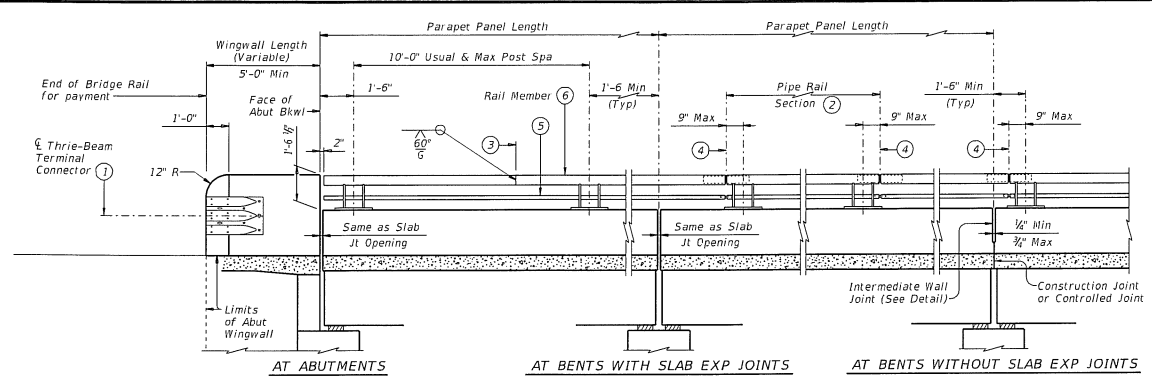

ROADWAY ELEVATION OF RAIL

(Rail Member showing Elliptical Tube Option, Rectangular Tube Option similar)

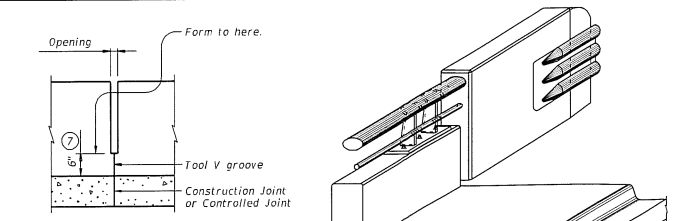

INTERMEDIATE WALL JOINT DETAIL

(Showing without raised sidewalk) Provide at all interior bents without slab expansion joints. Space equally in between at 3' Max, 10' Min. Location independent of rail member splices.

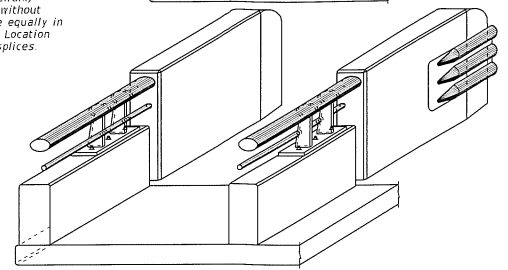

ISOMETRIC VIEWS AT END OF BRIDGE

(Rail Member showing Elliptical Tube Option, Rectangular Tube Option similar)

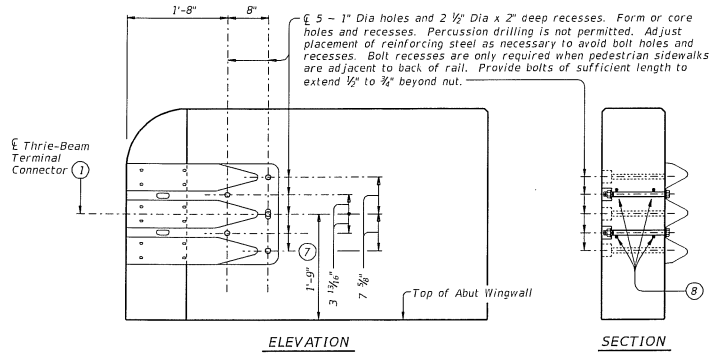

TERMINAL CONNECTION DETAILS

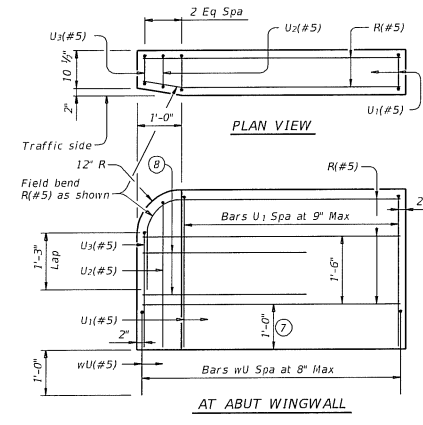

ELEVATION SHOWING TYPICAL REINFORCING PLACEMENT

(Showing without raised sidewalk)

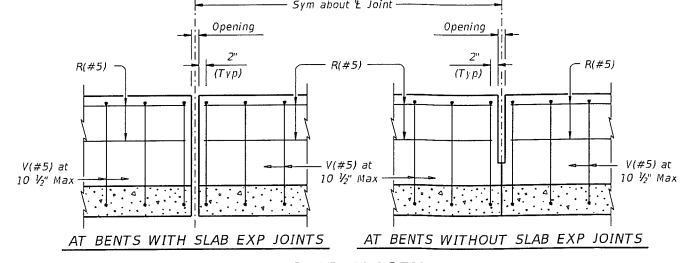

AT BENTS WITH SLAB EXP JOINTS AT BENTS WITHOUT SLAB EXP JOINTS

- ① Terminal Connectors and associated hardware are to be paid for under the Item "Metal Beam Guard Fence". Attach Metal Beam Guard Fence Transitions to the bridge rail and extend along the embankment unless otherwise shown in the plans.
- ② Pipe rail sections must have at least two posts but not more than four.
- ③ One shop splice per pipe rail section is permitted with minimum 85 percent penetration. The weld may be square groove or single vee groove. Grind smooth.
- ④ Exp Jt or Splice Jt as required.
- ⑤ 2" Dia Std Pipe (2.375" O.D., 0.154" wall thickness) (ASTM A53 Gr B, A1085 or A500 Gr B). Placed on sidewalk side of rail.
- ⑥ Unless directed otherwise by the Engineer, the Fabricator may use the rectangular tube in lieu of the elliptical tube for the rail member.
- ⑦ Increase 2" for structures with overlay.
- ⑧ Place 4 additional Bars R(#5) 3'-8" in length inside Bars U(#5) and centered 2'-0" from end of rail when Terminal Connections are required. Field bend as needed.

		Bridge Division Standard		
				COMBINATION RAIL TYPE C402
FILE: r13rd020-18.2.gpr	ENR: TxDOT	CR: TxDOT	DR: JTR	DT: JHM
©TxDOT March 2018	CONF	SECT	108	HW&L&L
REVIS	COUNTY	SHEET NO.		

DISCONTINUED
 The use of this standard is governed by the Texas Engineering Practice Act. No warranty of any kind is made by TxDOT for any purpose whatsoever. TxDOT assumes no responsibility for the conversion of this standard to other formats or for incorrect results or damages resulting from its use.

DATE: _____
 FILE: _____

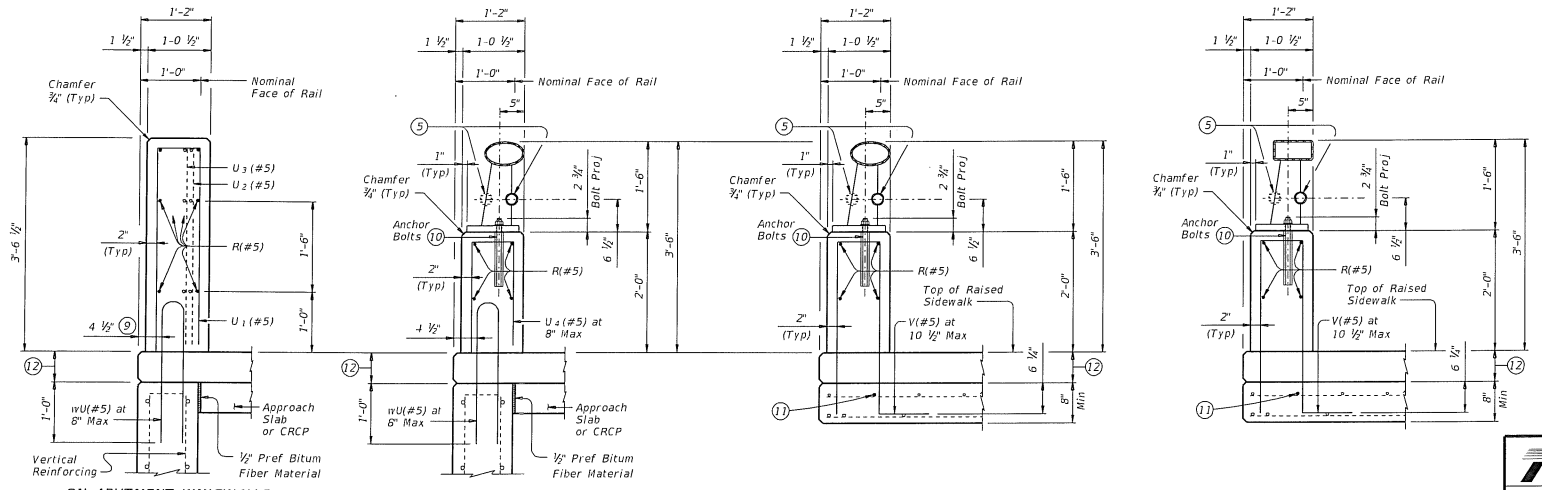
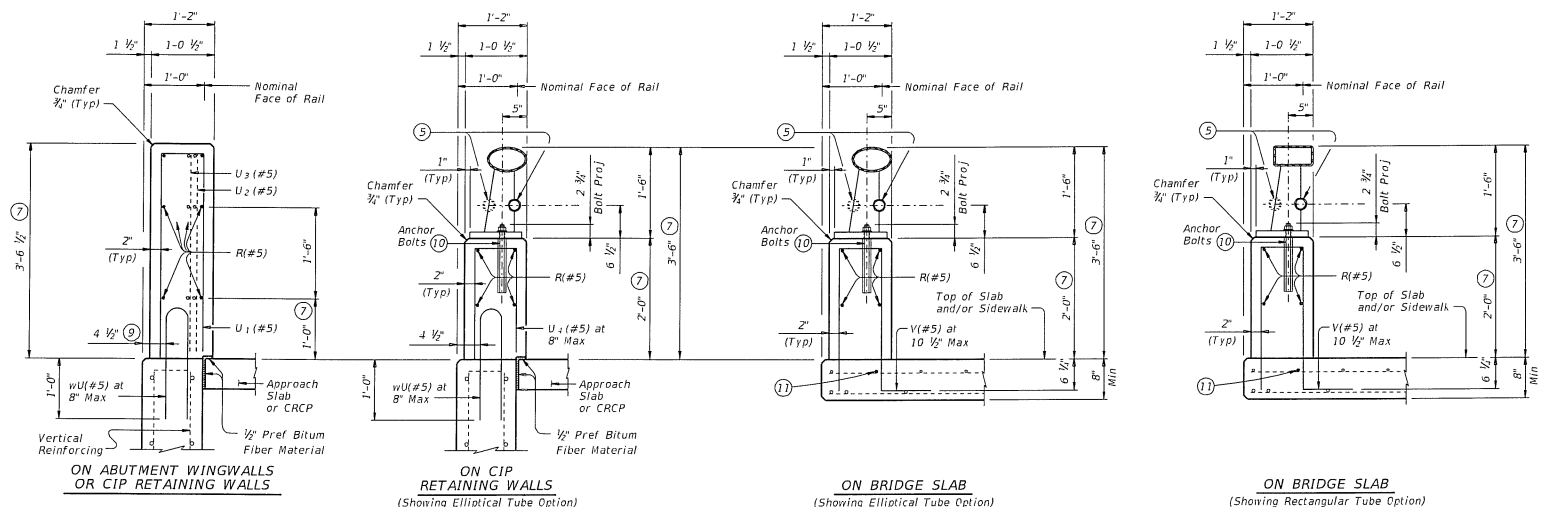

SECTIONS THRU RAIL WITHOUT RAISED SIDEWALK ⑥

SECTIONS THRU RAIL WITH RAISED SIDEWALK ⑥

- ⑤ 2" Dia Std Pipe (2.375" O.D., 0.154" wall thickness) (ASTM A53 Gr B, A1085 or A500 Gr B). Placed on sidewalk side of rail.
- ⑥ Unless directed otherwise by the Engineer, the Fabricator may use the rectangular tube in lieu of the elliptical tube for the rail member.
- ⑦ Increase 2" for structures with overlay.
- ⑧ 5 1/2" when vertical reinforcing has closer clear cover over horizontal reinforcing in abutment wingwalls or retaining walls on traffic side of wall.
- ⑩ See "Material Notes" for anchor bolt information.
- ⑪ Top longitudinal slab bar may be adjusted laterally 3" plus or minus to tie reinforcing.
- ⑫ Raised Sidewalk

		Bridge Division Standard	
<h2 style="margin: 0;">COMBINATION RAIL</h2>			
<h3 style="margin: 0;">TYPE C402</h3>			
FILE: 1134020-18.dgn DATE: March 2018	DESIGNED BY: JTR CHECKED BY: JTR	DRAWN BY: JTR APPROVED BY: JTR	SHEET NO.

DISCLAIMER: The use of this standard is governed by the Texas Engineering Practice Act. No warranty of any kind is made by TxDOT for any purpose whatsoever. TxDOT assumes no responsibility for the conversion of this standard to other formats or for incorrect results or damages resulting from its use.

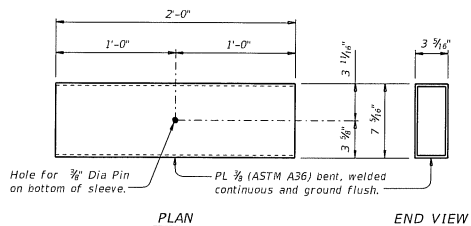

PLAN END VIEW

RECTANGULAR TUBE SLEEVE MEMBER DETAIL

(See Tube Fabrication Detail)

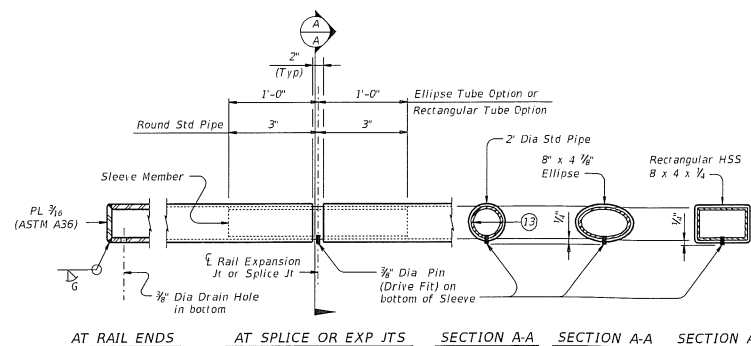

AT RAIL ENDS AT SPLICE OR EXP JTS SECTION A-A SECTION A-A SECTION A-A

TUBE FABRICATION DETAILS ⑥

ELLIPTICAL TUBE & ELLIPTICAL SLEEVE MEMBER

8" x 4 1/4" Ellipse		Elliptical Sleeve Member	
Material	Material	Material	Thickness
6" Dia Std Pipe	ASTM A53 Gr B	ASTM A53 Gr B	0.353"
ASTM A53 E or S Gr B)	ASTM A36 or A500 Gr B	API-5LX52	0.339"
6 3/4" O.D. Pipe x 0.188" API-5LX52	ASTM A53 Gr B	ASTM A36 or A500 Gr B	0.325"
	ASTM A36 or A500 Gr B	API-5LX52	0.188"

Notes: Other sections of equal or greater strength are acceptable for elliptical sleeves. The major and minor diameters of the rail member may vary +/- 0.1875" from plan dimension. However, the difference between the outside diameters of the elliptical sleeve and the inside diameters of the rail member must not exceed 0.25 inches.

- ⑤ 2" Dia Std Pipe (2.375" O.D., 0.154" wall thickness) (ASTM A53 Gr B, A1085 or A500 Gr B). Placed on sidewalk side of rail.
- ⑥ Unless directed otherwise by the Engineer, the fabricator may use the rectangular tube in lieu of the elliptical tube for the rail member.
- ⑬ Sleeve Member 1 1/2" Dia Std Pipe (1.90" O.D., 0.145" wall thickness) (ASTM A53 Gr B or A500 Gr B).

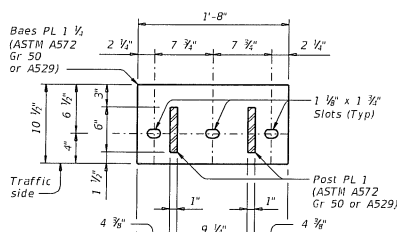

SECTION THRU POST

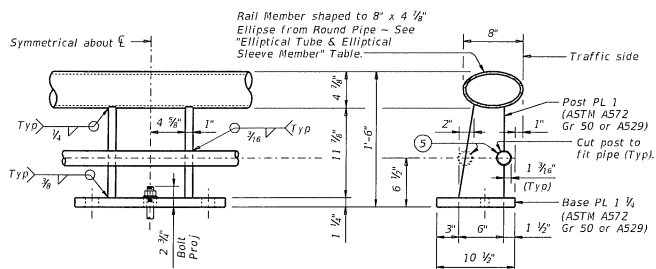

ELEVATION

SECTION THRU RAIL

ELLIPTICAL TUBE WITH RAIL POST & ANCHORAGE DETAILS

(Showing Elliptical Tube Option)

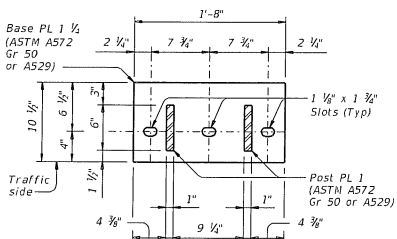

SECTION THRU POST

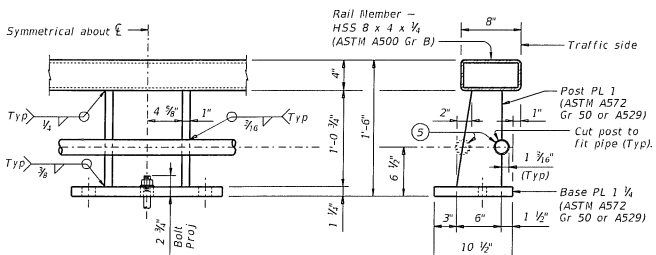

ELEVATION

SECTION THRU RAIL

RECTANGULAR TUBE WITH RAIL POST & ANCHORAGE DETAILS ⑥

(Showing Rectangular Tube Option)

DATE: FILE:

		Bridge Division Standard	
COMBINATION RAIL			
TYPE C402			
FILE: 11st020-18.020	REV: TxDOT	CHK: TxDOT	ENR: JTR
DATE: March 2018	DESIGN: SECT	NO: 108	REVISION: 1
DISP:	COUNTY:	SHEET NO.:	

DISCLAIMER: This standard is approved by the Texas Engineers' Practice Act. No warranty of any kind is made by TxDOT for any purpose whatsoever. TxDOT assumes no responsibility for the use of this standard or for incorrect results or damages resulting from its use.

DATE: _____
PAGE: _____

RAIL DATA FOR HORIZONTAL CURVES			
	RADIUS TO FACE OF RAIL	MAX CHORD LENGTH	CONSTRUCT OR FABRICATE
Rail Members	Over 2800'	29'-0"	Straight rail sections
	Over 1400' thru 2800'	14'-6"	To required radius or to chords shown
	Over 700' thru 1400'	7'-3"	To required radius
	Thru 700'	Zero	To required radius

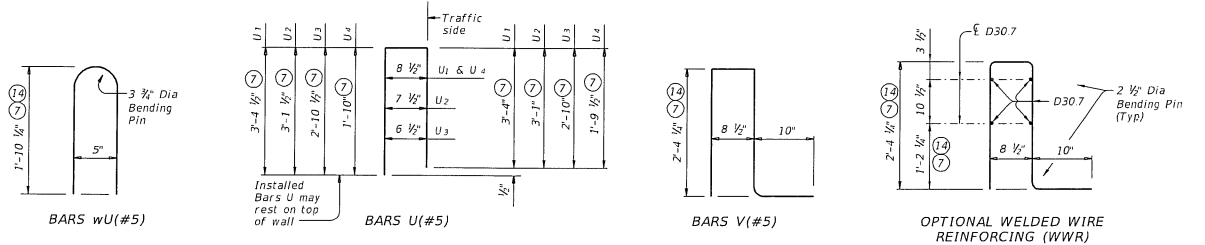

- ⑦ Increase Z" for structures with overlay.
- ⑩ See "Material Notes" for anchor bolt information.
- ⑭ For raised sidewalks, add sidewalk height to total bar height. Use sidewalk height at rail's location.
- ⑮ Slots are not allowed in areas where there is a joint in the concrete parapet between rail posts.
- ⑯ Shop drawings for approval required for tubular steel sections.

CONSTRUCTION NOTES:
 This rail may be slip-formed if approved by the Engineer when epoxy adhesive anchor bolts are used.
 Cap all open ends of tubular steel sections.
 At the Contractor's option anchor bolts may be cast with the parapet. See "Material Notes". Slip-forming parapet is not allowed if anchor bolts are cast with parapet wall.
 Test adhesive anchors in accordance with Item 450.3.3, "Tests". Test 3 anchors per 100 anchors installed. Perform corrective measures to provide adequate capacity if any of the tests do not meet the required test load. Repair damage from testing as directed.
 Rail parapet must be plumb unless otherwise approved. Steel posts must be square to the top of parapet. Use Type VIII epoxy mortar under post base plates if gaps larger than 1/4" exist.
 Pipe rail sections must have at least two posts but not more than four.
 Round or chamfer all exposed edges of steel components 1/8" by grinding prior to galvanizing.
 Chamfer all exposed concrete corners.

MATERIAL NOTES:
 Galvanize all metal components of steel rail system. Apply additional coatings when shown elsewhere on the plans. When plans require paint over galvanizing, follow the requirements for painting galvanized steel in Item 445, "Galvanizing" and when field painting, Item 446, "Field Cleaning and Painting Steel". Sleeve members and anchor bolts must receive galvanization prior to installation and only field paint after installation unless directed otherwise by Engineer.
 Anchor bolts must be 3/8" Dia ASTM A193 Gr B7 fully threaded rods with heavy hex nuts, one hardened steel washer ASTM F436, and one (2 1/2" O.D.) steel washer each. Nuts must conform to ASTM A563 requirements. Embed fully threaded rods into parapet wall with a Type III, Class C, D, E, or F anchor adhesive. Minimum adhesive anchor embedment depth is 8". Anchor adhesive chosen must be able to achieve a nominal bond strength in tension of a single anchor, R_a , of 17 kips (edge distance must be accounted for). Submit signed and sealed calculations or the manufacturer's published literature showing the proposed anchor adhesive's ability to develop this load to the Engineer for approval prior to use. Anchor installation, including hole size, drilling, and clean out, must be in accordance with Item 450, "Railings".
 Optional cast-in-place anchor bolts must be 1/2" Dia ASTM F3125 Gr A325 or A449 bolts (or A193 Gr B7 or F1554 Gr 105 threaded rods with one tack welded heavy hex nut each) with one heavy hex nut and one hardened steel washer ASTM F436 plus one (2 1/2" O.D.) steel washer at each bolt. Nuts must conform to ASTM A563 requirements.
 Provide Class "C" concrete. Provide Class "C" (HPC) if required elsewhere.
 Provide Grade 60 reinforcing steel.
 Epoxy coat or galvanize all reinforcing steel if slab bars are epoxy coated or galvanized. Deformed Welded Wire Reinforcement (WWR) ASTM A1064 may be substituted for Bars R, and V, as shown. Provide the same laps as required for reinforcing bars.
 Provide bar laps, where required, as follows: Uncoated or galvanized - #5 = 2'-0" Epoxy coated - #5 = 3'-0"

GENERAL NOTES:
 This rail has been evaluated and accepted to be of equal strength to railings with like geometry, which have been crash tested to meet NCHRP Report 350 TL-3 criteria. This rail can be used for speeds of 50 mph and greater when a TL-3 rated guard fence transition is used. When a TL-2 rated guard fence transition is used, this rail can only be used for speeds of 45 mph and less.
 Do not use this railing on bridges with expansion joints providing more than 5" movement.
 Rail anchorage details shown on this standard may require modification for select structure types. See appropriate details elsewhere in plans for these modifications.
 Submit erection drawings showing panel lengths, rail post spacing, and anchor bolt setting, to the Engineer for approval.
 Average weight of railing with no overlay: 347 plf total
 313 plf (Conc)
 34 plf (Steel).

Cover dimensions are clear dimensions, unless noted otherwise.
 Reinforcing bar dimensions shown are out-to-out of bar.

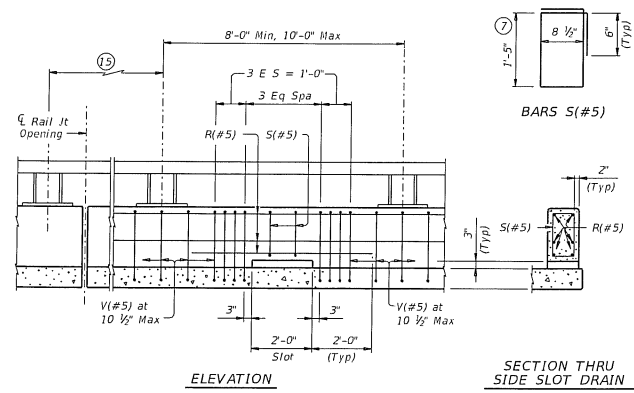

OPTIONAL SIDE SLOT DRAIN DETAILS

Note: Center Side Slot Drains between rail posts within the limits shown. Side Slot Drains may be used where shown elsewhere on the plans or as directed by the Engineer. Do not place drains over railroad tracks, lower roadways, or sidewalks. When this rail is used as a separator between a roadway surface and a sidewalk surface, side drain slots will not be permitted.

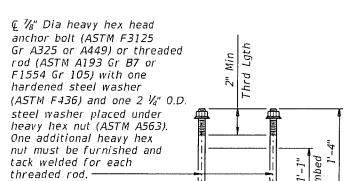

CAST-IN-PLACE ANCHOR BOLT OPTIONS

Texas Department of Transportation		Bridge Division Standard	
COMBINATION RAIL			
TYPE C402			
FILE: r15e020-18.dgn	DW: TADOT	CK: TADOT	DR: JTR
DATE: March 2018	CONST: SECT	NOB: 000	REVISION: 000
REV: 000	CONV: 000	SHEET NO.	