

SS90™ HD TMA

Product Description Assembly Manual

Part No. 618542B

Created April 2012



SS90TMHD TMA

Product Description Assembly Manual



2525 Stemmons Freeway
Dallas, Texas 75207



IMPORTANT: These instructions are to be used only in conjunction with the assembly, maintenance, and repair of the SS90TMHD TMA. These instructions are for standard assemblies specified by the appropriate highway authority only. In the event the specified system assembly, maintenance, or repair would require a deviation from standard assembly parameters, contact the appropriate highway authority engineer. This system has been accepted by the Federal Highway Administration for use on the national highway system under strict criteria utilized by that agency. Energy Absorption Systems representatives are available for consultation if required.

This Manual must be available to the worker overseeing and/or assembling the product at all times. For additional copies, contact Energy Absorption Systems at (888) 323-6374 or download from websites below.

The instructions contained in this Manual supersede all previous information and Manuals. All information, illustrations, and specifications in this Manual are based on the latest SS90TMHD TMA information available to Energy Absorption Systems at the time of printing. We reserve the right to make changes at any time. Please contact Energy Absorption Systems to confirm that you are referring to the most current instructions.

Table of Contents

Customer Service Contacts	3
Important Introductory Notes	3
Return Goods Policy	4
Recommended Safety Rules for Assembly	4
Safety Symbols	4
Warnings and Cautions.....	5
Limitations and Warnings.....	7
Safety Instructions	8
Attachment Instructions	14
Operation Instructions.....	27
Maintenance	29
Repair Instructions	37
Troubleshooting Guide.....	42
Test Equipment	42
Hydraulic Fluid.....	43
Pump Priming.....	44
Reservoirs	44
Filters.....	45
Hydraulic Cylinders	45
Electrical Problems.....	46
Hydraulic Quick Troubleshooting Guide	49
Underride Assembly, Receiver, TMA	51
Pre-Assembly, Frame, 8292.....	52
Pre-Assembly, Frame, 8292, EUG	54
Miscellaneous Hardware, 8292	56
Hydraulic/Electrical Assembly, 8292	57
Lighting Assembly, LED, 12V, 8292.....	60
Lighting Assembly, Incandescent, 12V, 8292	63
Lighting Assembly, Incandescent, 24V, 8292	66
Rear Plate Assembly, w/Striping, 8292	69

Customer Service Contacts

Energy Absorption Systems (a Trinity Highway Products company) is committed to the highest level of customer service. Feedback regarding the SS90^{TMHD} TMA, its assembly procedures, supporting documentation, and performance is always welcome. Additional information can be obtained from contact information below:

Energy Absorption Systems:

Telephone:	(888) 323-6374 (USA Only) (312) 467-6750 (USA or International)
E-mail:	customerservice@energyabsorption.com
Internet: Energy Absorption Systems Trinity Highway Products, LLC Trinity Industries, Inc.	http://www.energyabsorption.com http://www.highwayguardrail.com http://www.trin.net

Important Introductory Notes

Proper assembly, deployment and future maintenance of the SS90^{TMHD} TMA are critical to achieve tested performance under accepted criteria. Take the time to review this Manual thoroughly before performing all necessary work. These instructions should be read in their entirety and understood before assembling the SS90^{TMHD} TMA. These instructions are to be used only in conjunction with the assembly of the SS90^{TMHD} TMA system and are for standard assemblies only as specified by the applicable highway authority.

In the event your system assembly requires or involves deviation from standard parameters or, during the assembly process a question arises, please contact the appropriate highway authority that specified this system at this particular location for guidance. Energy Absorption Systems is available for consultation with that agency. These instructions are intended for an individual who is qualified to both read and accurately interpret them as written. They are intended for the individual who is experienced and skilled in the assembly of highway products which are specified and selected by the highway authority.

Do not attempt to assemble any TMA without the proper plans and specifications from the highway authority and instructional Manual from the manufacturer. If you need additional information, or have questions about the SS90^{TMHD} TMA, please contact the highway authority that has planned and specified this assembly. This product must be assembled by the appropriate highway authority just as it was tested. If there are deviations, alterations, or departures from the assembly protocol specified in this Manual, the device may not perform as it was tested and accepted.

Return Goods Policy

Before returning any goods for credit, please contact Energy Absorption Systems Customer Service Department at 1-888-323-6374 or your local distributor for proper instructions.



Important: Read safety instructions thoroughly and follow the assembly directions and suggested safe practices before assembling, maintaining, or repairing the SS90^{TMHD} TMA. Failure to follow this warning can result in serious injury or death to the worker and/or bystanders. Further, it could render the product unacceptable for use by the FHWA. Please keep these instructions for later use.



Warning: Ensure that all of the SS90^{TMHD} TMA Warnings, Cautions, and Important Statements within the SS90^{TMHD} TMA Manual are completely followed. Failure to follow these warnings could result in serious injury or death in the event of a collision.

Recommended Safety Rules for Assembly

*** Important Safety Instructions ***

This Manual must be kept in a location where it is readily available to persons who assemble, maintain, or repair the SS90^{TMHD} TMA. Additional copies of this Manual are immediately available from Energy Absorption Systems by calling (888) 323-6374 or by e-mail at customerservice@energyabsorption.com. Please contact Energy Absorption Systems if you have any questions concerning the information in this Manual or about the SS90^{TMHD} TMA. This Manual may also be downloaded directly from the websites indicated above.

Always use appropriate safety precautions when operating power equipment, mixing chemicals, and when moving heavy equipment or the SS90^{TMHD} TMA components. Gloves, safety goggles, and back protection should be used.

Safety measures incorporating traffic control devices must be used to provide safety for personnel while at the assembly, maintenance, or repair site.

Safety Symbols

This section describes safety symbols that may appear in the SS90^{TMHD} TMA Manual. Read the Manual for complete safety, assembly, operating, maintenance, repair, and service information.

Symbol

Meaning



Safety Alert Symbol Indicates Danger, Warning, or Caution. Failure to read and follow the Danger, Warning, Safety, or Caution indicators could result in serious injury or death to the workers and/or bystanders.

Warnings and Cautions

Read all instructions before assembling, maintaining, or repairing the SS90^{TMHD} TMA



Warning: Read the instructions carefully. Be familiar with the complete instructions for the SS90^{TMHD} TMA before assembling, maintaining, or repairing the SS90^{TMHD} TMA. Failure to follow this warning could result in serious injury or death in the event of a collision.



Warning: Do not assemble, maintain, or repair the SS90^{TMHD} TMA until you have read this Manual thoroughly and completely understand it. Ensure that all Warnings, Cautions, and Important Statements within the Manual are completely followed. Please call Energy Absorption Systems at (888) 323-6374 if you do not understand these instructions. Failure to follow this warning could result in serious injury or death in the event of a collision.



Warning: Safety measures incorporating traffic control devices must be used to protect all personnel while at the assembly, maintenance, or repair site. Failure to follow this warning could result in serious injury or death in the event of a collision.



Warning: Be sure adequate time is available for complete assembly, maintenance, or repair before beginning the assembly, maintenance, or repair process. Failure to follow this warning could result in serious injury or death in the event of a collision.



Warning: Use only specified Energy Absorption Systems parts for assembling, maintaining, or repairing the SS90^{TMHD} TMA. Assembly, maintenance, or repairs using unauthorized accessories or those not specifically dedicated to the SS90^{TMHD} TMA is strictly prohibited, even if they have been manufactured and/or sold by Energy Absorption Systems or Trinity Industries. Such configurations have not been tested, nor have they been accepted for use. Assembly, maintenance, or repairs using unspecified parts or accessories is strictly prohibited. Failure to follow this warning could result in serious injury or death in the event of a vehicle impact with an UNACCEPTED system.



Warning: Do NOT modify the SS90^{TMHD} TMA in any way. Failure to follow this warning could result in serious injury or death in the event of a collision.



Warning: Ensure that the SS90^{TMHD} TMA and delineation used meet all federal, state, specifying agency, and local specifications. Failure to follow this warning could result in serious injury or death in the event of a collision.



Warning: Ensure that your assembly meets all appropriate Manual on Uniform Traffic Control Devices (MUTCD) and local standards. Failure to follow this warning could result in serious injury or death in the event of a collision.



Warning: Ensure that all warnings, cautions, and important statements within the SS90^{TMHD} TMA Manual are completely followed. Failure to follow this warning could result in serious injury or death in the event of a collision.



Warning: Failure to follow these warnings and cautions could result in serious injury or death.

Limitations and Warnings

Energy Absorption Systems, in compliance with the National Cooperative Research Highway Program 350 (NCHRP Report 350) "Recommended Procedures for the Safety Performance of Highway Safety Features", contracts with FHWA approved testing facilities to perform crash tests, evaluation of tests, and submittal of results to the Federal Highway Administration for review.

The SS90^{TMHD} TMA system was tested to meet the impact criteria, requirements, and guidelines of NCHRP Report 350. These tests, specifically set forth by FHWA, evaluate product performance by simulating those impacts outlined by NCHRP Report 350 involving a typical range of vehicles on our roadways, from lightweight cars (approx. 820kg [1800 lb.]) to full size pickup trucks (approx. 2000 kg [4400 lb.]) as specified by the FHWA. A product can be certified for multiple Test Levels. The SS90^{TMHD} TMA is certified to the Test Level(s) as shown in Test Level III: 100 km/h [62.13 mph].

Additionally, the SS90^{TMHD} TMA was tested to meet the impact criteria, requirements, and guidelines of TD 49. These tests are specifically set forth by The UK Highway Authority. The SS90^{TMHD} TMA is certified for various speed levels as shown in TL3.UK: 110 km/h [68 mph]

These specified tests are not intended to represent the performance of systems when impacted by every vehicle type or every impact condition existing on the roadway. This system is tested only to the test matrix criteria of NCHRP 350 as approved by FHWA or TD 49 as approved by The UK Highway Authority.

Energy Absorption Systems does not represent nor warrant that the results of these controlled tests show that vehicle impacts with the products in other conditions would necessarily avoid injury to person(s) or property. Impacts that exceed the specifications of the system may not result in acceptable crash performance as outlined in NCHRP Report 350, relative to structural adequacy, occupant risk, and vehicle trajectory. Energy Absorption Systems expressly disclaims any warrant or liability for injury or damage to persons or property resulting from any impact, collision, or harmful contact with products, other vehicles, or nearby hazards or objects by any vehicle, object or person, whether or not the products were installed by third parties.

SS90^{TMHD} TMA system is intended to be assembled, delineated, and maintained in accordance with specific State and Federal guidelines. Energy Absorption Systems offers a reflective delineator panel for its TMA line of products. However, the material is only intended to supplement delineation required by the Department of Transportation's "Manual on Uniform Traffic Control Devices" (MUTCD). The appropriate highway authority approved engineer should be careful to properly select, assemble, and maintain the product. Careful evaluation of the speed, traffic direction, and visibility are some of the elements that require evaluation in the proper selection of a safety appurtenance by the appropriate specifying highway authority.

After an impact occurs, the product must be repaired to its original condition as soon as possible. When a safety product is impacted, it is mandatory that the highway authority inspect all the components for damage and repair and/or replace components as necessary. If the system is not repairable, a complete system replacement is required.

Safety Instructions

For maximum safety, the operator should stand at the rear of the truck, on the curb side, (see Figure 2). When tilting the TMA, care should be taken to stay clear of all moving parts.

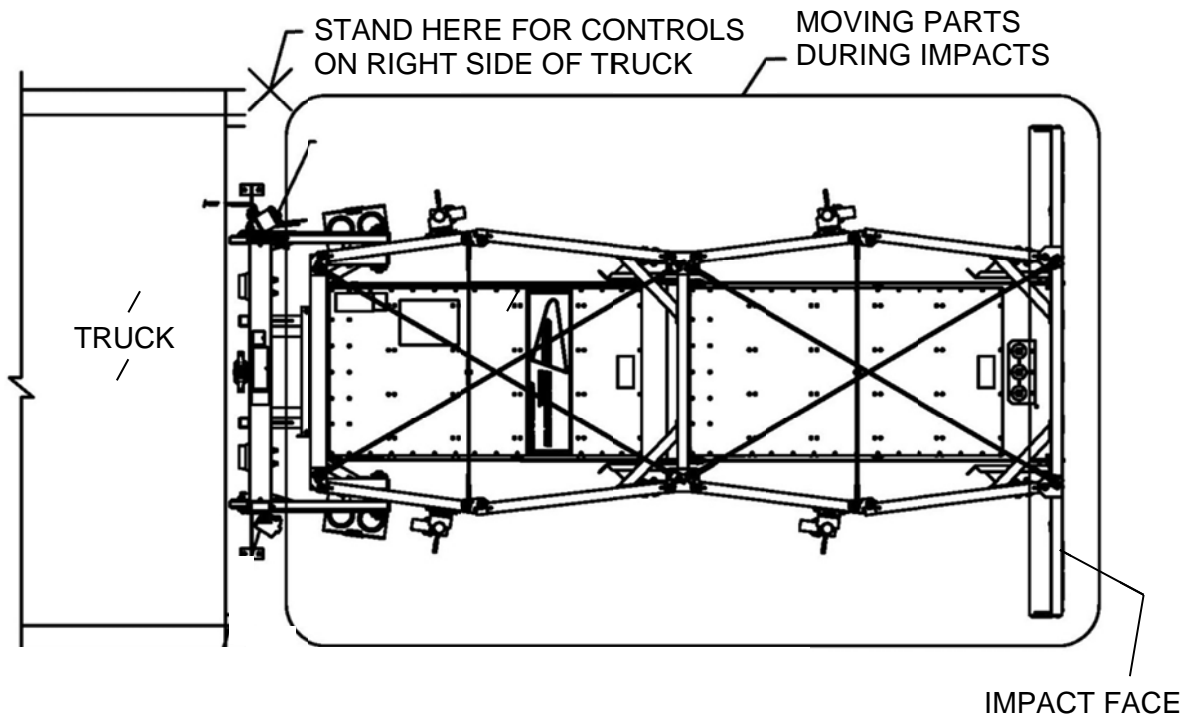
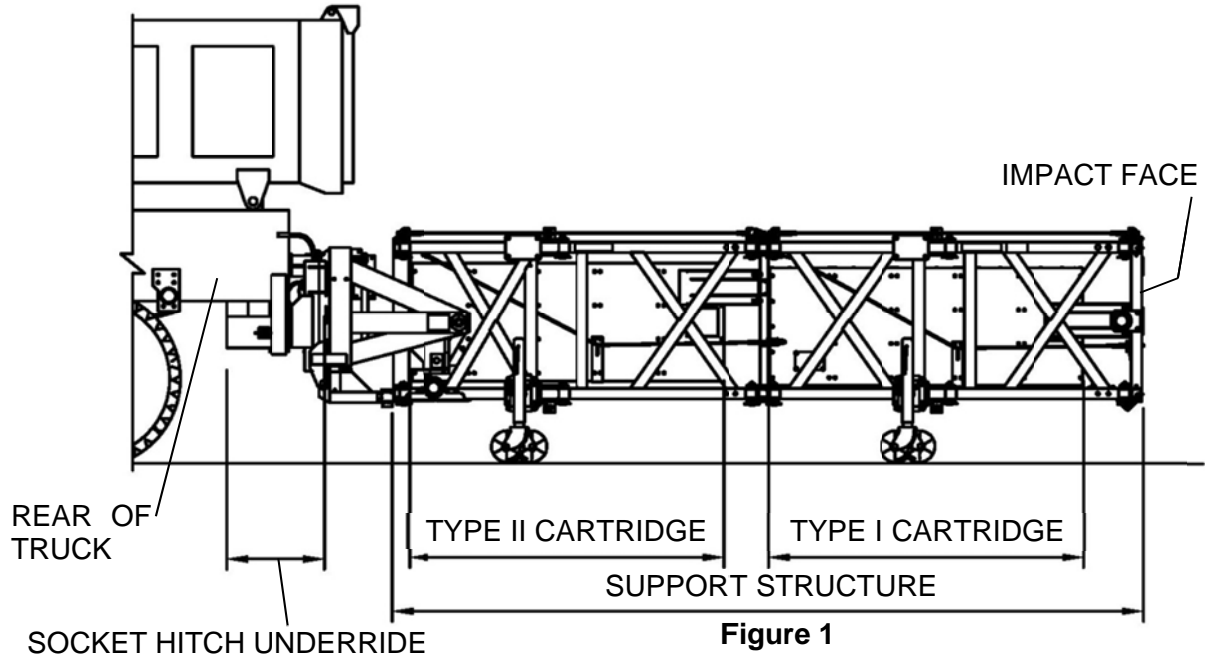

1. The TMA should be rigidly fastened to the truck. In the horizontal position, the bottom of the TMA should be 280 to 330 mm [11" to 13"] from the ground and level (see Figure 3). The TMA must be left in the down position whenever possible. The TMA can only absorb the energy of an impacting vehicle within NCHRP criteria in the down position.

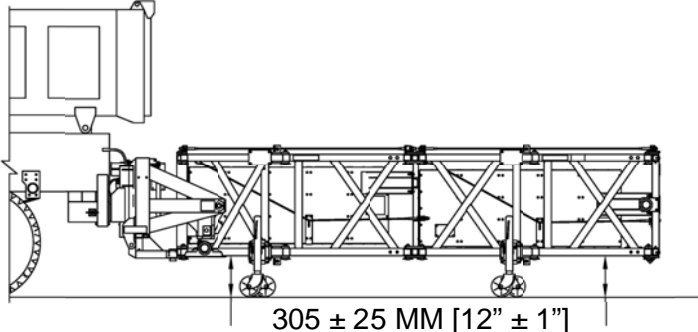

Figure 3

2. Jacks may be used to support the TMA when it is off the truck (See Figure 3). The Jacks must be stored while the TMA is attached to the truck (See Figure 4).

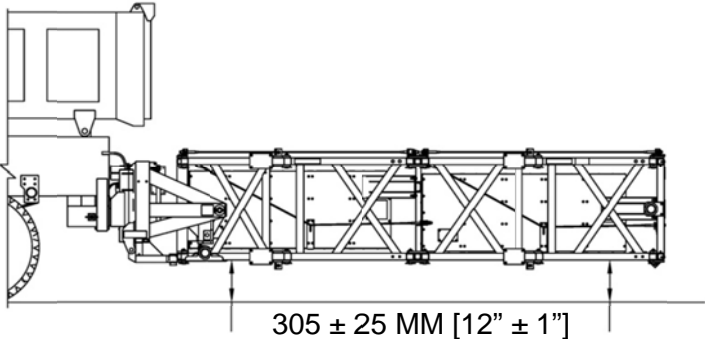

Figure 4

3. Make sure all pivot pins are in position and that all retaining pins are installed correctly. (See Figures 5 and 29)

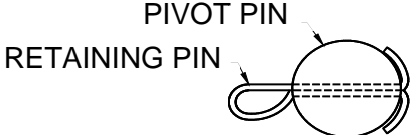

Figure 5

4. SS90™HD TMA has been shown to absorb an impact within the criteria of NCHRP-350 testing, and to support its own weight. Do not drag the TMA or place anything on its top: damage may result (See Figure 6). Do not sit, stand, or lean on any part of the TMA.

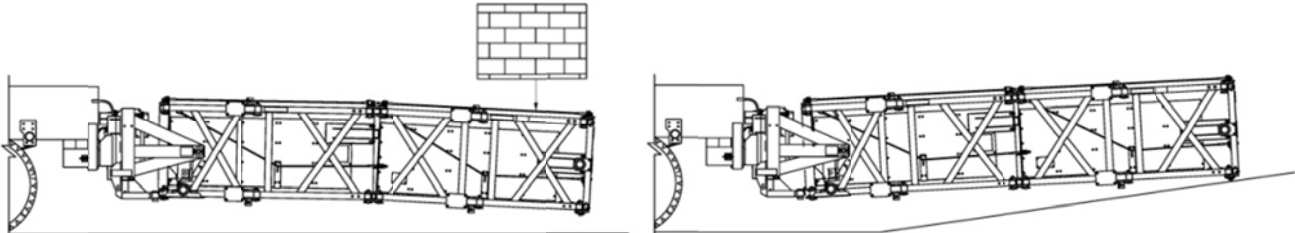

Figure 6

5. Before raising or lowering the TMA, the operator should be trained as to its proper operation. Refer to the Operation Instructions in this Manual.
6. When traveling long distances or storing the TMA in the 90 degree (vertical) position, secure the Frame with the Retaining Chain to guard against hydraulic system bleed-down (see Figures 7 & 8b).
7. Be sure all persons are standing clear before raising or lowering the TMA. No one should be below the system when lowering it, or removing any retaining chain. Be sure the system is stopped and locked in full up position before allowing anyone directly behind the elevated system (see Figures 7, 8a & 8b).



Danger: No one shall be allowed to stand behind or in the path of a moving or unlocked TMA. Failure to follow this warning could result in serious injury or death.

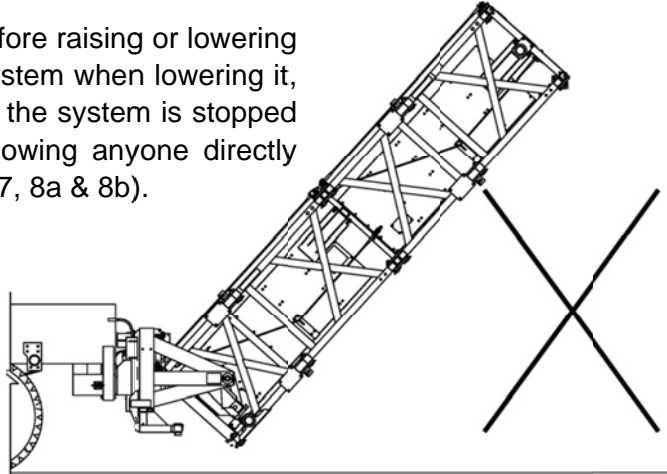
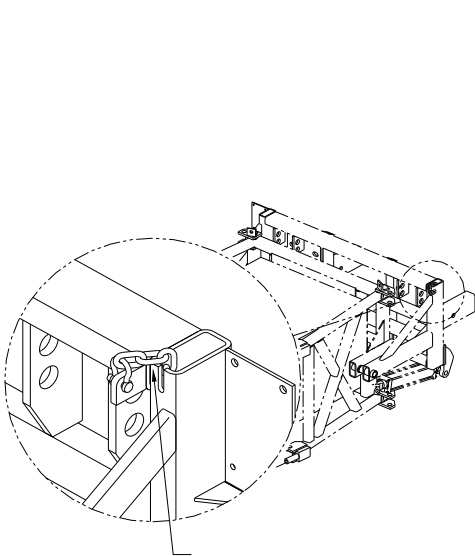
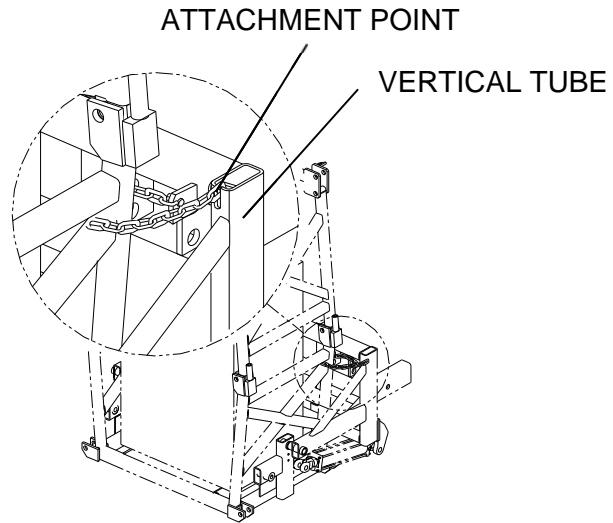

Figure 7



PLACE THE RETAINING CHAIN INTO THE VERTICAL TUBE FOR STORAGE WITH THE TMA IN THE DOWN POSITION

Figure 8a



WHEN THE TMA IS IN THE UP POSITION, PULL THE RETAINING CHAIN OUT OF THE VERTICAL TUBE, WRAP THE CHAIN AROUND THE FRAME ARM AND SECURE IT TO THE ATTACHMENT POINT

Figure 8b

- Ballast and other heavy objects **MUST BE ADEQUATELY ANCHORED** to the truck to prevent shifting during an impact (See Figure 9). (The force on the tie-down straps could be 20 times the weight of the ballast.)

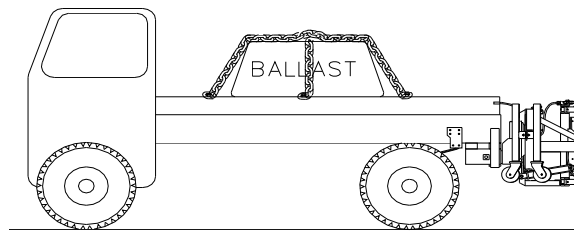

Figure 9

- The agency or authority responsible for the truck should inspect it for adequate operator safety equipment (e.g., seat belts, head rests, etc.).
- It is recommended that the SS90^{TMHD} TMA be mounted to trucks between 7300 kg [16,090 lbs.] and 9000 kg [19,845 lbs.] for tested impact performance.
- Make sure that the performance and safety of the TMA is not impaired by damage or corrosion.



Warning: Failure to comply with these instructions can result in improper TMA performance and possible personal injury. This TMA is intended to be used as a crash attenuator on the rear of trucks which meet the design specifications for this system. The TMA should not be used for any other purpose.

- Regular maintenance of the TMA is important for safe use. Refer to the Maintenance section of this Manual for additional information.
 - Regular inspection of Frame members, Cartridges and pins is necessary to ensure proper system performance.
 - Regular maintenance of hoses is important. A broken or damaged hose may cause the system to lower at a faster and unsafe rate.
 - Keep electrical connections at the pump motor/solenoid clean to prevent arcing. Clean any hydraulic spills or leakage to prevent bodily injury, fire, etc.
- The driver should be extra cautious while backing the truck with the TMA in the up or down position, so that injury and/or damage will not result.
- The driver should be extra cautious while making turns with the TMA in the down position. The TMA extends beyond the end of the truck and will swing wide at corners.
- When traveling long distances or storing the TMA in the 70-90° (vertical) position, secure the frame with the retaining chain to guard against hydraulic system bleed-down (See Figure 8b).
- This system is a crash cushion and is therefore used in high traffic risk areas. Stay clear of traffic whenever possible. If an accident is to occur, even during an impact, within NCHRP 350 criteria there may be fragments from the truck or impacting vehicle that could cause injury.

17. The hydraulic assembly was designed to lift and lower the TMA system as described. Any other use may be hazardous to people or equipment.
- Do not use the system to push a load.
 - Do not use the raised end of the system to support any load.
 - Do not use any part of the TMA for towing or hauling a load. This could cause the lift mechanism to malfunction and may reduce the impact performance.
 - Do not use the TMA as a ladder.
18. The system must be in the horizontal position to perform properly during an impact. Do not leave the system raised, even slightly, when on the job.
19. Be sure the truck is appropriate for attaching a TMA. See the Assembly instructions for further details.

Definitions:

A BARRIER VEHICLE is a truck on which a TMA is mounted, while positioned upstream (towards the direction that traffic is approaching) of a work zone.

A SHADOW VEHICLE is a truck on which a TMA is mounted, which is following behind a moving operation such as striping, spraying, etc.

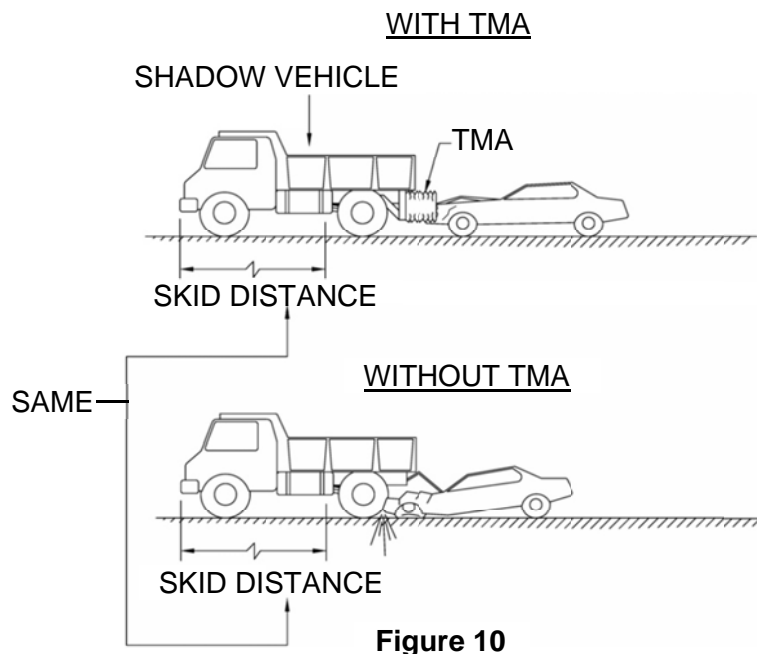

THE USE OF A TMA ON THE BACK OF A TRUCK, WHEN IMPACTED WITHIN NCHRP 350 CRITERIA, HAS BEEN SHOWN TO:

- Gradually stop the impacting vehicle*
- Protect the occupants of the impacting vehicle*
- Protect the shadow vehicle occupants*
- Reduce damage to the shadow vehicle*

WILL NOT:

- Affect the skid (roll ahead) distance of an impacted truck. **KEEP WORK CREWS CLEAR!**

REDUCING SKID DISTANCE (ROLL AHEAD):

- Skid distance is significantly increased and is less predictable for lightweight shadow vehicles
- Skid distance is reduced and is more consistent when heavier shadow vehicles are used.
- Preferred truck GVW rating is:
7300 kg [16,090 lbs.] to 12 000 kg [26,460 lbs.]
- Recommended Curb Weight is:
7300 kg [16,090 lbs.] to 9000 kg [19,845 lbs.]

***TMA'S HAVE BEEN TESTED UNDER THE FOLLOWING NCHRP-350 CRITERIA:**

- 100 km/h [62 mph] for 820 and 2000 kg [1808 and 4410 lbs.] vehicles.

***TMA'S HAVE ALSO BEEN TESTED UNDER THE FOLLOWING UK TD 49 CRITERIA:**

- 110 km/h for 900 and 1500 kg vehicles.

Attachment Instructions

Read and understand all instructions before beginning assembly.

The truck rating (GVW) should be 7300 [16,090 lbs.] min. The weight of the vehicle should be between 7300 and 9000 kg [16,090 and 19,845 lbs.] to achieve impact performance under state and federal guidelines.

The system must be attached to the truck by welding parts to the frame. Do not weld forward of the rear leaf spring hangers to ensure structural integrity of frame. Use AWS qualified welders to ensure durable attachment of the TMA system. Disconnect the truck battery before any welding on truck or TMA.

The truck frame must be suitable and accessible for mounting a TMA system. If there are any questions regarding the suitability, contact the agency that specified this System. Energy Absorption Systems is available for consultation through that agency.

1) Shipping list

Check the shipping list against the actual parts to make sure all items were received. Review the drawing package and familiarize yourself with the assembly and part numbers.

2) Assemble Necessary Tools

Recommended Tools:

- | | |
|---|---|
| 1. Welding equipment (for 1/2" plate)
GMAW or SMAW | 10. Work gloves and other personal
protection equipment as required. |
| 2. Hammer | 11. Cutting torch |
| 3. Tape measure | 12. Drift pin or alignment pin (12" long) |
| 4. 1/2" drive sockets (9/16", 1-1/8",
1-1/2", 9/16" deep well) | 13. 1/2" drive socket wrench w/6" extension |
| 5. 12" crescent wrenches - (2) | 14. Open end wrenches (9/16", 1-1/8", 1-1/2") |
| 6. Floor jack | 15. Marking implement (pencil, soapstone) |
| 7. 13/16" diameter bit with pilot drill | 16. Drill motor for 13/16" diameter bit |
| 8. Torque wrench - 120 Nm [90 ft-lbs.] | 17. Center punch |
| 9. Forklift | 18. Hydraulic fluid (use Dexron® III fluid only,
shipped with system.) |
| | 19. Bubble level |

Note: The above list of tools is a general recommendation. Depending on specific site conditions and the complexity of the assembly specified by the appropriate highway authority, additional or fewer tools may be required. Decisions as to what tools are needed to perform the job are entirely within the discretion of the specifying highway authority and the authority's selected contractor performing the assembly of the system at the authority's specified site.

Preparation

3A) Attachment Must Be Performed On a Level Surface

The system's framework is very heavy and pivots in several areas. Until the framework is secured with the alignment cables and release cables, it can swing out in an approximate 4 m [13'] radius from either side of the truck. A level surface is required to maintain control of the framework when it is being extended to its full length.

3B) Truck Ballast

Use a bubble level to verify that the truck is parked on a level surface. The truck should be as close to the final driving weight as possible. If ballast must be added to achieve the 7300 kg [16,090 lbs] minimum weight, add it at this time. Ballast must be properly anchored to the truck to keep it in place during an impact. Ideally, an adequately sized truck, that requires no ballast, should be used. Because the 910 kg [2000 lb] weight of the rearward protruding TMA is supported by the back of the shadow vehicle, care must be taken not to exceed the manufacturer's published maximum axle loads. To ensure that the driving characteristics of the vehicle are maintained, the manufacturer's recommended center-of-gravity zone should also be adhered to.

4) Check for Interference

Before attempting to attach the Underride, check for interference problems.

The system rotates very close to the mounting location (See Figure 38 on Page 36). If you are using something other than a standard socket receiver hitch underride, refer to special instructions supplied with your assembly, then skip to step 8.

Temporarily position the Underride Socket Receiver under truck frame as shown (refer to Figure 12) and check for interference problems. Interference problems with tail lights, springs, dump bodies (in the up or down positions), etc., should be corrected before proceeding.

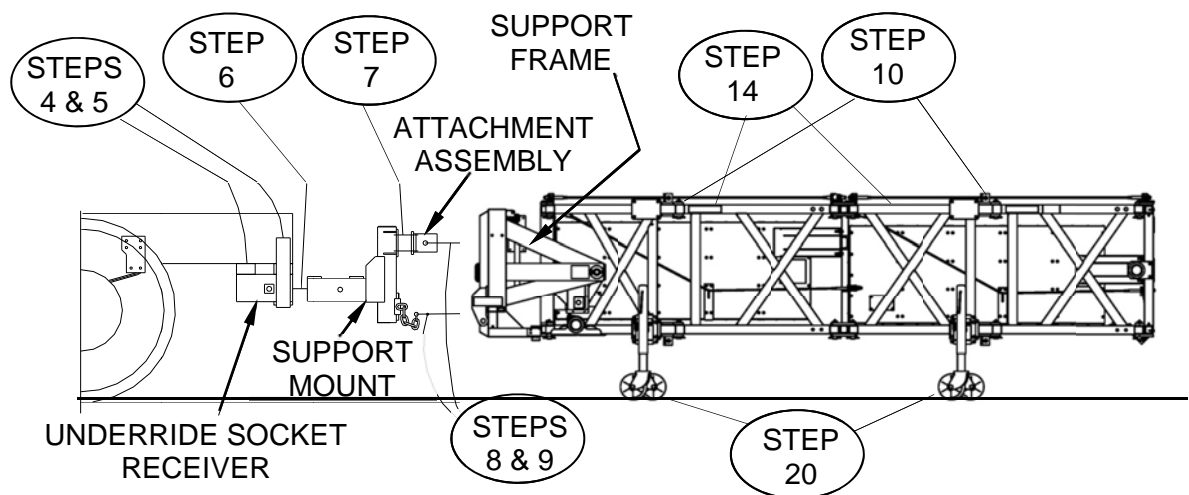

Figure 11

5) Underride Assembly

Park the truck on a level surface. Make sure the truck is at its actual driving weight. Measure the distance from the ground to the bottom of the truck frame. A distance of 711 ± 25 mm [28 ± 1 "] is required. Spacers may be added to the bottom of the frame to achieve this height (See Underride Assembly drawing).



Important: The truck's springs may settle with the weight of the TMA, sometimes, as much as 50 mm [2"]. Adjust the height to compensate for anticipated settling.

Measure from the back end of the frame forward to the rear-most leaf spring hanger, or any other obstruction on the bottom of the frame that may interfere with the Socket Receiver. A minimum of 305 mm [12"] is required (See Underride Assembly drawing).

Position the Socket Receiver at the rear end of the frame so that the 76 x 387 mm [3" x 15 1/4"] flat bar is along the outside of the frame member and the Socket Receiver Tube is flush with the end of frame. If Spacers are required, weld them to the Receiver Tube and lap the Spacer Splices (pieces of 10 x 51 x 103 mm [3/8 x 2 x 4"] flat bar) across the Socket Receiver Tube and Spacer at the rear-most location (See Underride Assembly drawing). The top of the Socket Receiver Tubes to be 711 ± 25 mm [28 ± 1 "] from the level ground for proper system height (See Figure 13).

Weld the Socket Receiver Tube to the bottom of the truck frame with the 76 x 387 mm [3 x 15 1/4"] flat bar on the outer side of the frame (See Figure 12).



Important: All welding must be performed by a welder certified to AWS D14.3-82 or AWS D1.1 in accordance with the Underride Assembly drawing. Disconnect truck battery before welding.



Warning: The truck frame is high carbon steel. To avoid cracking, do not weld or apply excessive heat to the bottom flange, forward of rear-most leaf spring hangers.

Prime and paint all welded areas.

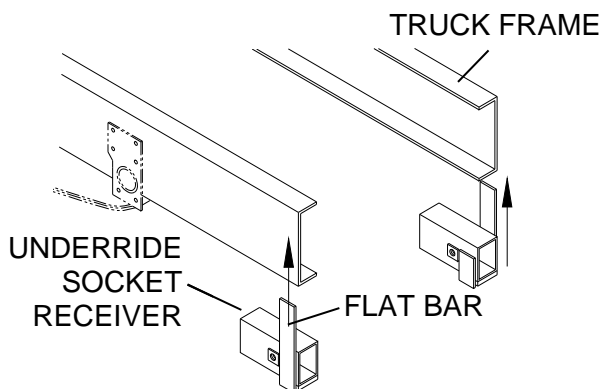

Figure 12

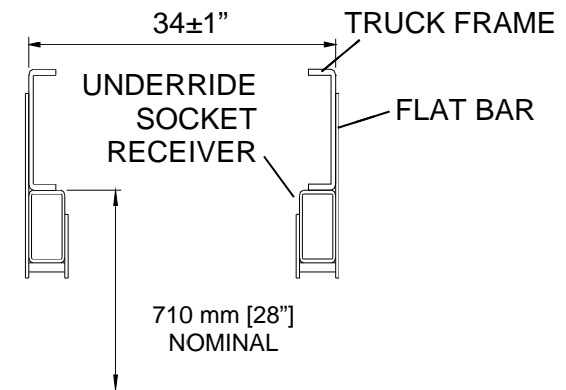
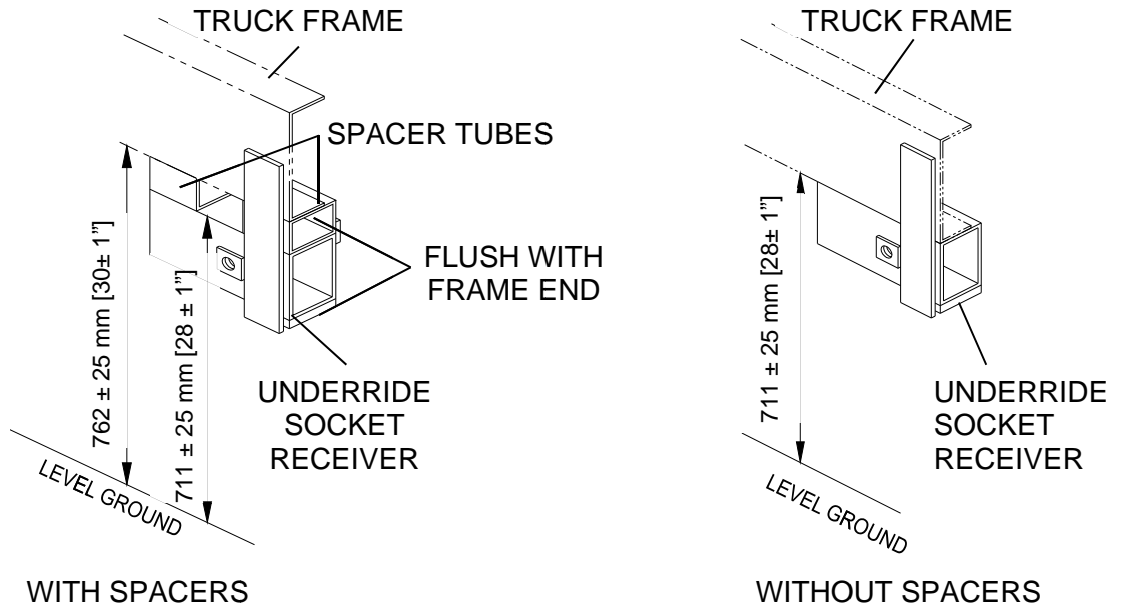

Figure 13



Important: Left and right Underride Socket Receivers must be parallel with each other and level.



**Figure 12 – Socket Hitch
Left Side Shown**

6. Socket Hitch Assembly

Inset the Socket Hitches and pin them into place using the 1 x 6 1/4" Hitch Pins and Retainer Pins shipped with the system.

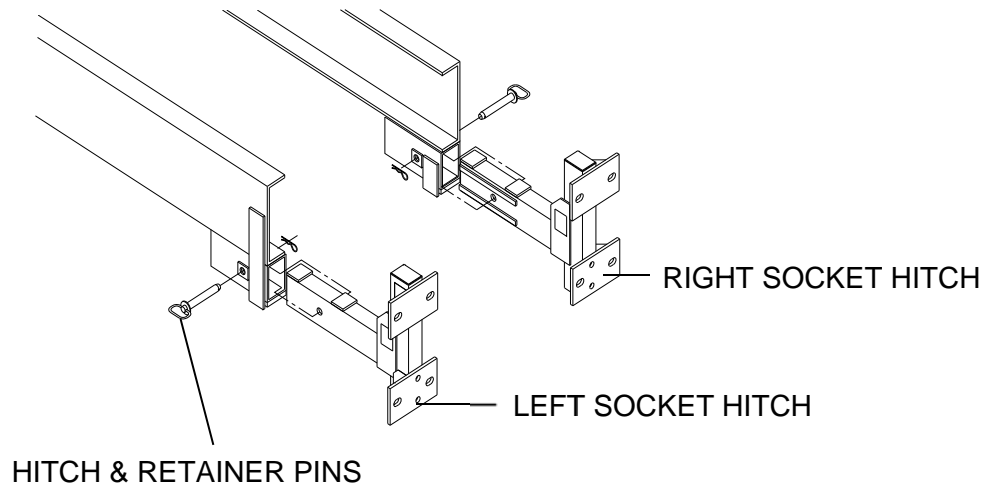

Figure 15

7. Mount the Attachment Assembly to Socket Receivers

Mount the Attachment Assembly to the Socket Hitches as shown in Figure 16. Shims are used to level the system. It is recommended that 1/2" Shims be used initially. This may be adjusted once the system is assembled.

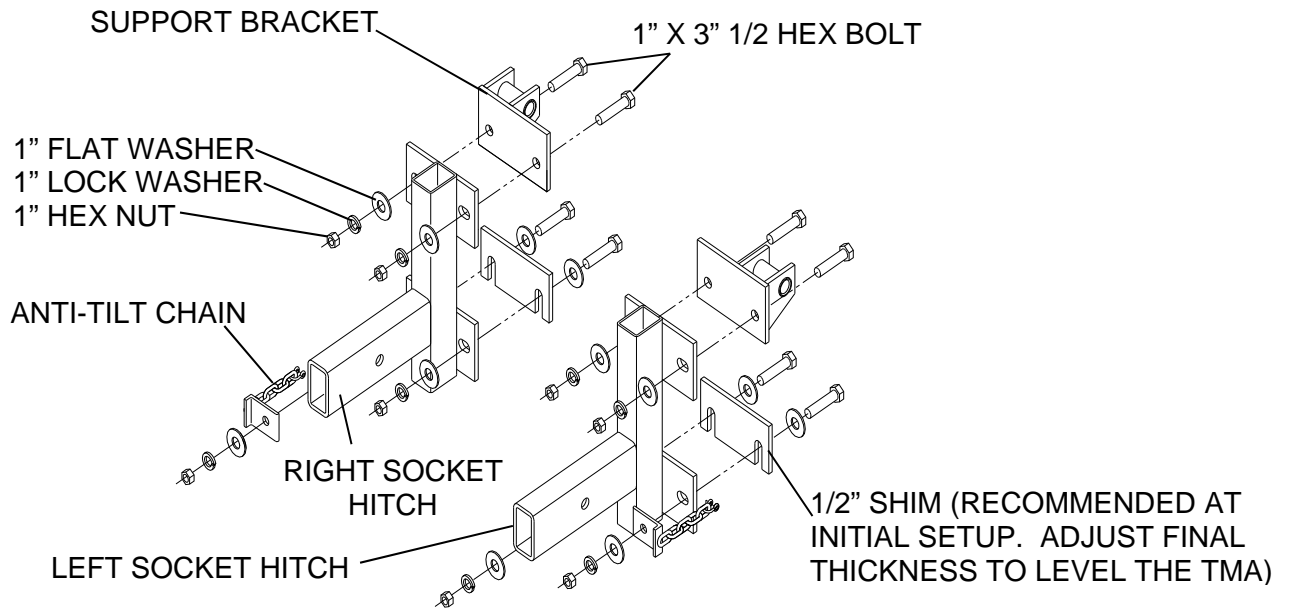

Figure 16

8. Attach the Support Frame/Backup to the Attachment Assembly

Move the Support Frame/Backup Assembly to the truck and pin it to the Attachment Assembly, as shown in Figure 17. The Support Frame/Backup Assembly is to be attached while frame is still collapsed, with forklift slings supporting the system. Use the upper set of mounting holes for the attachment. Electrical Box is temporarily held by zip ties and may need to be removed for clearance issues.

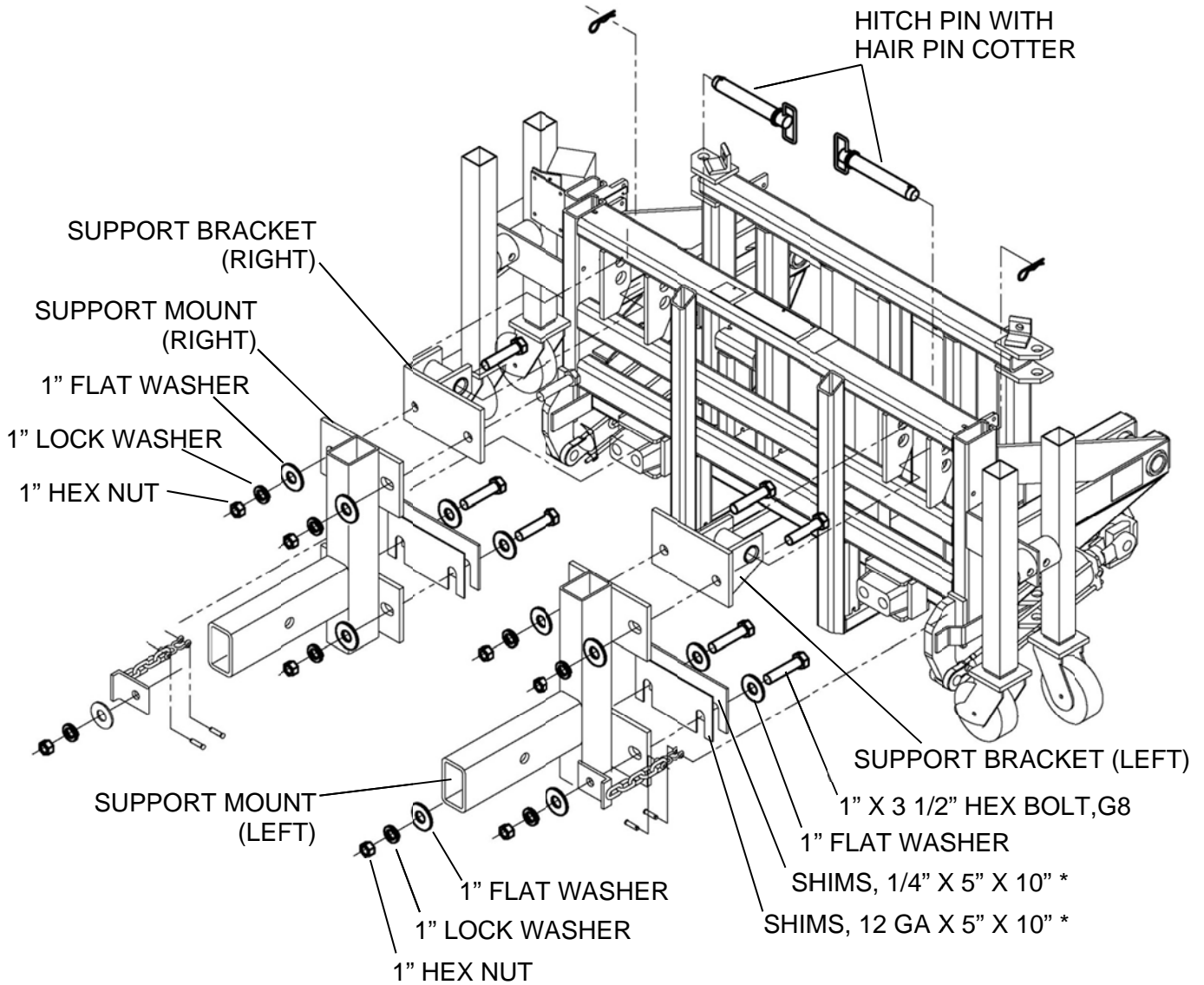

Figure 17

9. Extend the Support Frame

With the TMA pinned to the Attachment Assembly, slowly and evenly pull the Frame Assembly out to its full extent.



Warning: Even when supported by the forklift, the frame can be unwieldy. Use extreme care. Failure to heed this warning could cause serious injury or death.



Warning: Until the cables are attached, the system could shift to one side.

10. Attach Corner Gussets

Using 1/2" bolts, nuts, flat washers and lock washers, attach Corner Gussets four places as shown in Figure 18.



Warning: When installing Corner Gussets, be careful of pinch points.

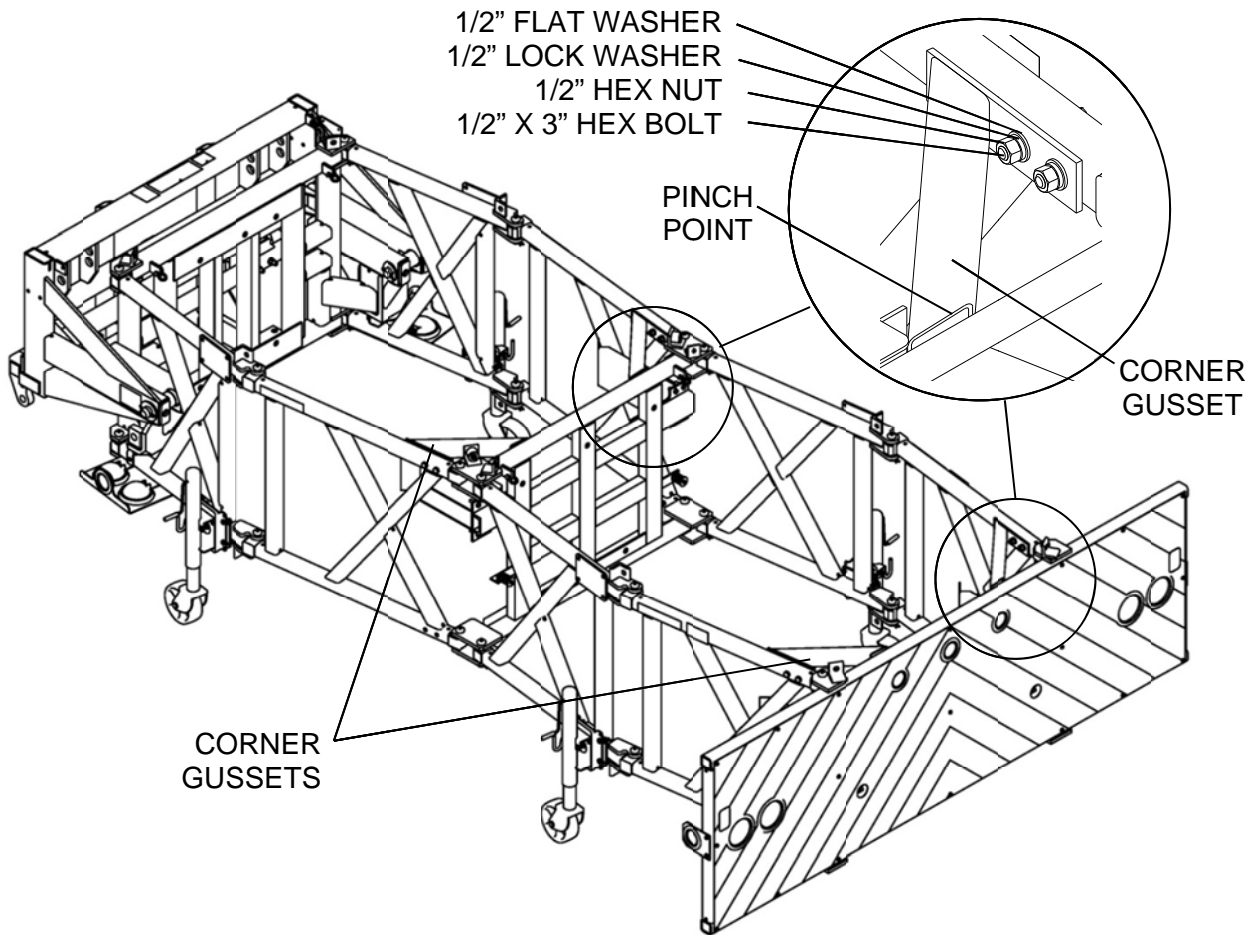

Figure 18

11. Attach the Bottom Release Cables across the Arm Assemblies.



Warning: For proper system performance, use only Release Cables supplied by Energy Absorption Systems. Failure to use the correct equipment could lead to fatigue or result in unpredictable system performance.

Verify that the Frame is extended as far as it will go. Attach the Bottom Release Cables across Arm Assemblies (See Figure 19). Torque the nuts to 34 -0/+3 Nm [25 - 0/+2 ft-lbs], making sure that roughly an equal amount of threads protrude from nuts on both ends of cable. Lock cable in place using remaining fasteners as "jam" nuts.

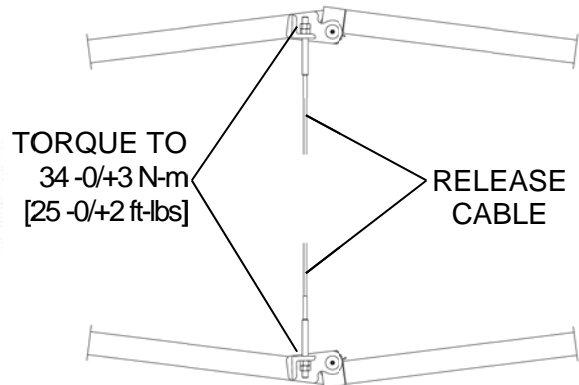

Figure 19

12. Attach Cartridges

(If Alignment Cables are already attached, remove one end of each Alignment Cable from the TMA and set aside to clear the top side of each bay.) Using a forklift and sling, place Cartridge I in position and secure it using the flat washers, lock washers, and nuts provided. Torque the nuts to 120 ± 7 N-m [90 ± 5 ft-lbs.] Repeat procedure for Cartridge II (See Figure 20).

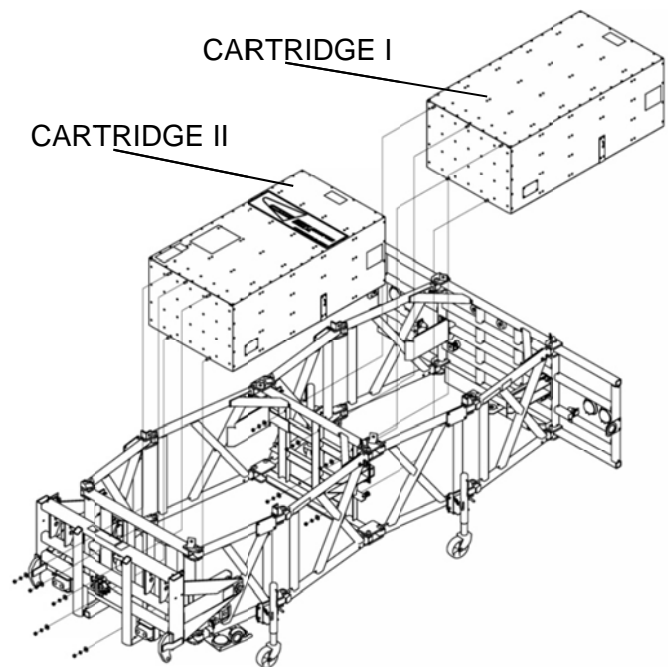

Figure 20

13. Attach the Top Release Cables across the Arm Assemblies

Attach the Top Release Cables across the Arm Assemblies (See Figure 19). Torque the nuts to 34 N-m (25 ft-lbs), making sure that roughly an equal amount of threads protrude from nuts on both ends of cable. Lock Release Cables in place using the remaining fasteners as "jam" nuts.

14. Attach and adjust Alignment Cables.

There are four Alignment Cables (two for each bay). Attach the Alignment Cables as shown in Figure 21. Measure the diagonals of each bay and adjust the cables so that the diagonal measurements in each bay are the same within the given tolerance ($A = B \pm 5$ mm [3/16"], $C = D \pm 5$ mm [3/16"]) and taut. Cables are "taut" when they deflect 38 mm - 50mm [1 1/2" - 2"] when pressed by hand at the center.



Important: The Die Springs, Spring Spacers, and flat washers (see Figure 21 and Detail B) are only used at mid-frame, on the front two Top Cables, i.e. the two cables closest to the truck.

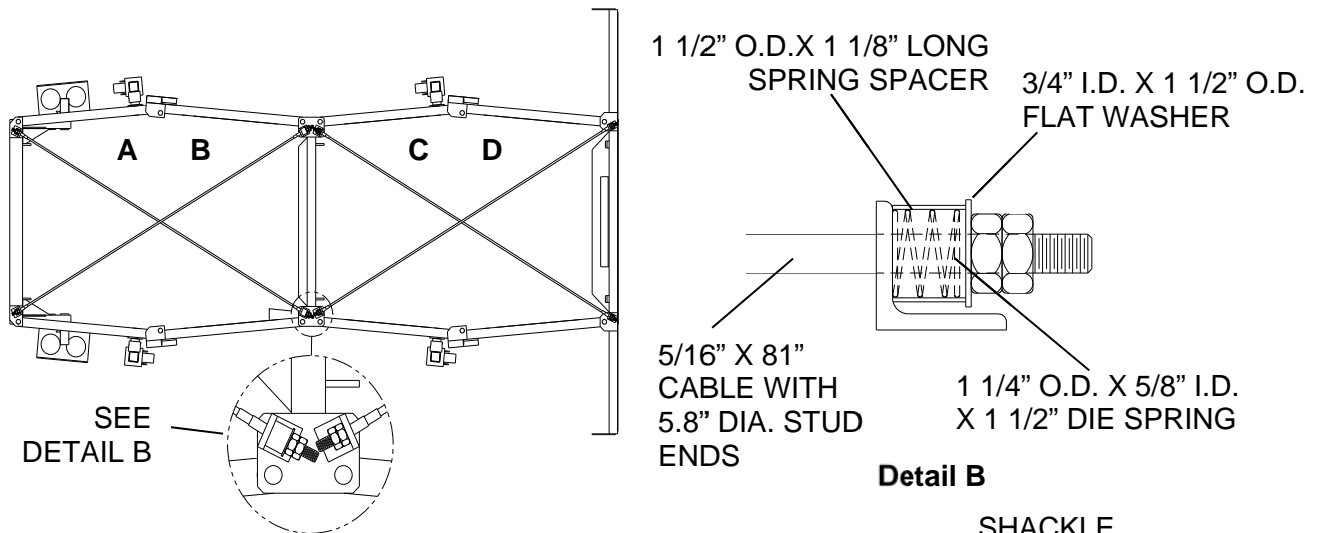

Figure 21 (Support Frame not shown for clarity)

15. Attach and adjust Cartridge Support Cables.

There are four Cartridge Support Cables. Attach thimble end of all Cartridge Support Cables to the Frame as shown using the provided shackles. Pass the stud end of the cable through the corresponding cartridge chain loop and attach as shown in Figure 22 using a die spring, washer, and nuts.

To properly tension the Cartridge Support Cables, tighten the first nut on one cable until all slack is removed, then tighten it until the Tensioning Spring has been compressed to 32 ± 2 mm [$1 \frac{1}{4} \pm 1/16$ "]. Lock this nut in place with the second "jam" nut. Repeat this procedure with other cables.

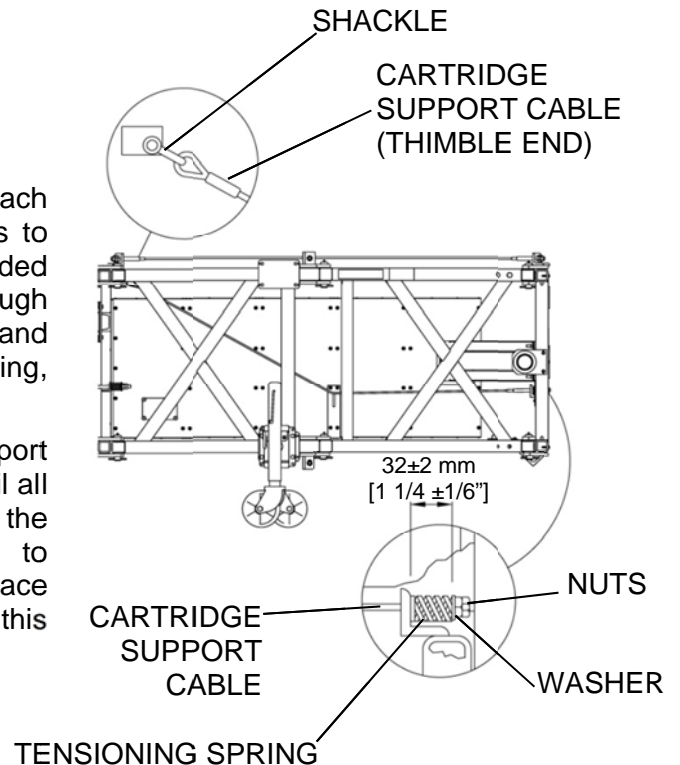

Figure 22

Created April 2012

All rights in copyright reserved

16. Attach Side Guides.

There are four Side Guides, two for Bay 1 and two for Bay 2. Attach Side Guides as shown in Figure 23 and tighten bolts.

17. Adjust height and levelness of the System Frame.

Verify that the system Frame is 305 ± 25 mm [12 ± 1]” from the ground at the front and rear of the system. It may be necessary to add or remove Shims from the Socket Hitch in order to adjust the levelness of the cartridge (See Figures 24 & 24a).

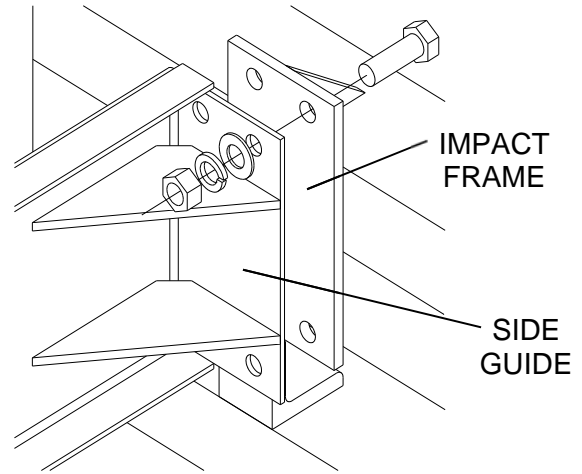
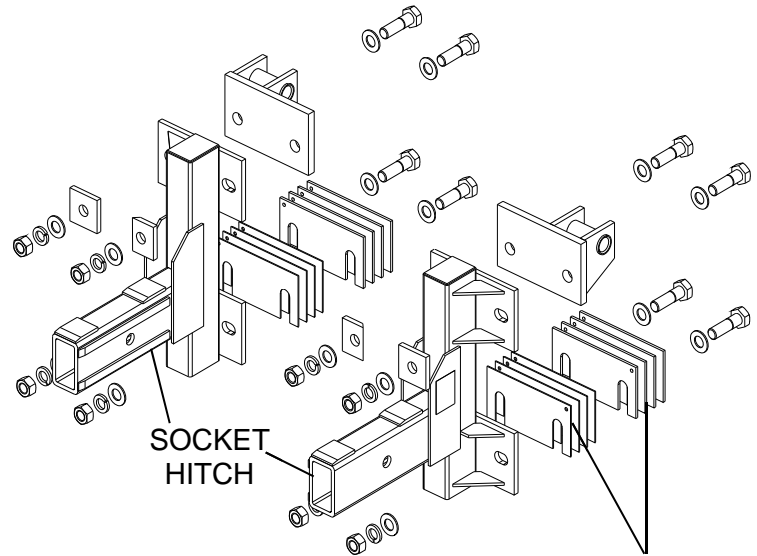

Figure 23



SHIMS MAY BE ADDED OR REMOVED HERE AS NECESSARY TO ACHIEVE LEVELNESS OF SYSTEM

Detail 24a

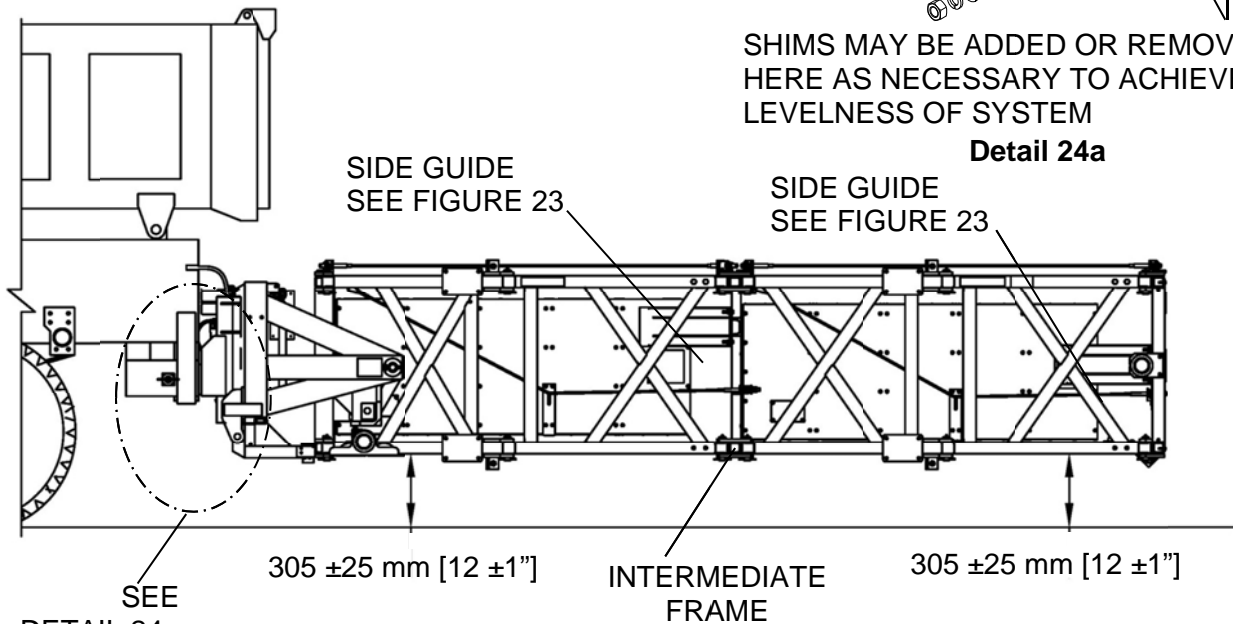

Figure 24

18. Connect the Lights and Controls.

Locate the female TMA socket connector in a convenient location on the truck, so that lifting or lowering the TMA will not damage the electrical cable. Make sure that the electrical cord on the TMA can reach this location.

For support vehicles with combined tail and clearance lights, connect a jumper between pins 2 and 6 on the backside of the male TMA plug connector (see VIEW A-A Figure 25.)

Install the Electrical Box to Plate mounted next to Pump (See Drawing 618586 on page 67) with the 4 bolts, washers and nuts on the Electrical Box. The truck battery must be of the proper voltage. The SS90^{TMHD} is available in 12 volt and 24 volt systems. Be sure the system and truck are compatible. Be sure to use standard safety practices when attaching the battery cables (e.g. do not let the ends of the cables touch, etc.) Do not run the battery cables around sharp corners or metal work, or in other areas that would pinch or cut the cables. Connect the battery cable to the pump motor (see the hydraulic assembly in drawing package).



Important: A 2 gauge battery cable is good up to 7.6 m [25 ft.] for a 12V system. If longer cable is needed use 1/0 gauge up to 12.5 m [44 ft.]. (A 2 gauge Battery Cable Kit with fusible link is available from Energy Absorption Systems, Part No. 618356B.) Both Power and Ground Cables should be connected directly to the battery.

The controls at the rear of the truck should be mounted to the Support Frame, on the non-traffic side (side closest to the curb). If they are not, remove the fasteners and move the controls to the other side. Securely fasten the controls to the existing mounting bracket. Mount the cab switch box inside the cab within easy reach of the driver.

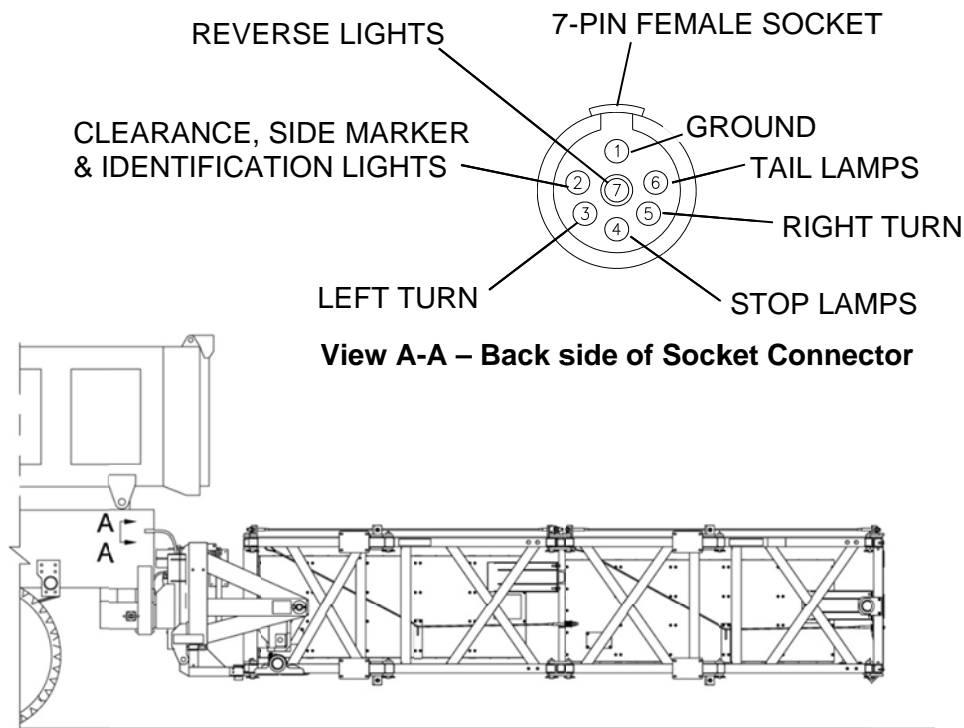

Figure 25

19. Check the Hydraulic System

The Hydraulic System is pre-assembled and tested for operation and leaks before shipping. The pump is wired as shown on the Hydraulic Assembly drawing. Before operating the system, remove the cap from the fill port of the hydraulic reservoir and check to see if the reservoir is full. Add only Dexron® III fluid if it is not. Do not overfill. Replace the vent plug in the filler port.

Read Operation Instructions. Making sure all electrical and hydraulic lines will not be damaged, use the switch at the rear of the truck, power the system up and down twice. This purges air from the system. Also cycle the system using the Cab Switches to verify proper operation.

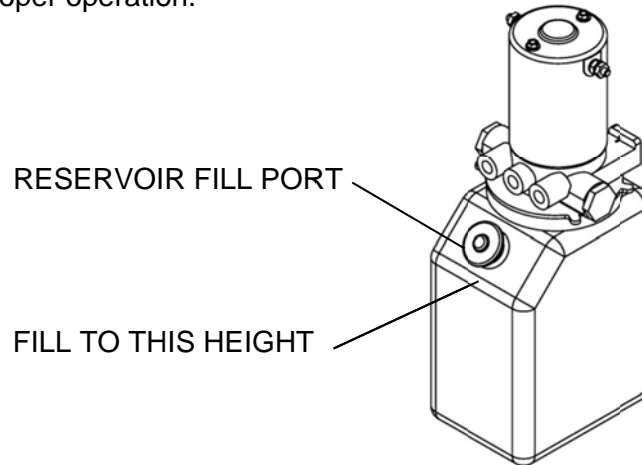

Figure 26



Important: Continuous operation may run down truck battery.

20. Remove and store Jacks

The Jacks are provided to facilitate attachment and removal of the system from the truck. Remove all four jacks and place them in storage.

21. Verify Turn-Stop-Tail Light Operation

Plug in the light cable. Verify that all the turn/stop/tail lights are working properly.

22. Check position of the Hydraulic/Electrical lines

Check the location of all the hydraulic and electrical lines to be sure they will not be damaged during turning or tilting of the system up or down.

23. Verify Hydraulic Locking in the Up Position

If the system is tilted from horizontal, the TMA's Hydraulic system will automatically lock when the switch is released. The pump is used to raise and lower the system.



Caution: Each time the TMA is raised, the operator should verify that the system is hydraulically locked and chained before allowing anyone behind the system.

24. Grease Friction Points

Follow directions in the maintenance section IV parts 2 & 3 before first use of TMA.

25. Final Check of System

Check the tightness of all of the fasteners. Double check the height and levelness of the system.

26. Ready for Use

The TMA system is now ready for use. To ensure proper and safe operation, all TMA users should be given operating and safety training, as given in this Manual and as specified by the owner and local regulations.

Operation Instructions

Before operating the SS90^{TMHD} TMA, thoroughly read and understand these instructions and the safety section of this Manual. Verify that the system is properly attached and in working order.

For impact performance per NCHRP-350 crash testing, the TMA must be equipped with one Cartridge I and one Cartridge II, in their proper positions as shown in Figure 20.

The SS90^{TMHD} TMA has been equipped with a Hydraulic Pump that can be used to tilt the TMA up from its horizontal position. The "tilting" feature may be used to prevent possible scraping of the rear end of the system as the truck travels in and out of sloped driveways. The operator simply activates the "up" button to tilt the TMA up. When he removes his finger from the button, the TMA will hydraulically lock. To lower the TMA, the operator simply activates the "Down" button. The Buzzer will continue to buzz (and rocker switch with flash on optional Cab Controller) until the TMA is either all the way up or down. (Optional In-Cab Controller is available, Part No. 618504B.)

The complete vertical "up" position allows the TMA equipped truck to be more easily driven and parked in congested areas. The driver must make sure everything is clear before lowering the TMA from the vertical (up) position.

The system can only perform as a crash cushion when the system is in the down position.

While raising or lowering the TMA from outside the cab, the operator is to stand on the non-traffic side of the truck. Always stay clear of moving parts. Never stand behind or below a lowering TMA, or allow others to be positioned there.

The controls are located on one side of the Support Frame. An optional set of controls can be located in the truck cab (Cab Controller Part No. 618504B).

Raise and Lower the System



DANGER: Make sure the top of the system is clear of all objects before proceeding. **Under no circumstances should anyone be allowed behind or in the path of the system when it is being raised or lowered.**

When operating from the cab, always be aware of objects behind or below the TMA.

Raising the system

To tilt the system up: Press and hold the "Raise" side of the Rocker Switch until the system reaches the 90-degree position. The hydraulics automatically locks the system when the Rocker Switch is released. In the 90 degree position, the Restraining Chain should be used to ensure that the system stays in the 90 degree position for long term storage and for maintenance.



Caution: If someone will be doing maintenance behind the raised system, or if the system is to be stored in the "up" position, be sure to secure the system with the Retaining Chain as shown in Figure 27.



DANGER: NEVER REMOVE RETAINING CHAINS WHILE WORK IS BEING PERFORMED.

WHEN THE TMA IS IN THE "UP" POSITION, STAND TO THE SIDE AND PULL THE RETAINING CHAIN OUT OF THE VERTICAL TUBE, WRAP THE CHAIN AROUND THE FRAME ARM AND SECURE IT INTO THE SLOT.

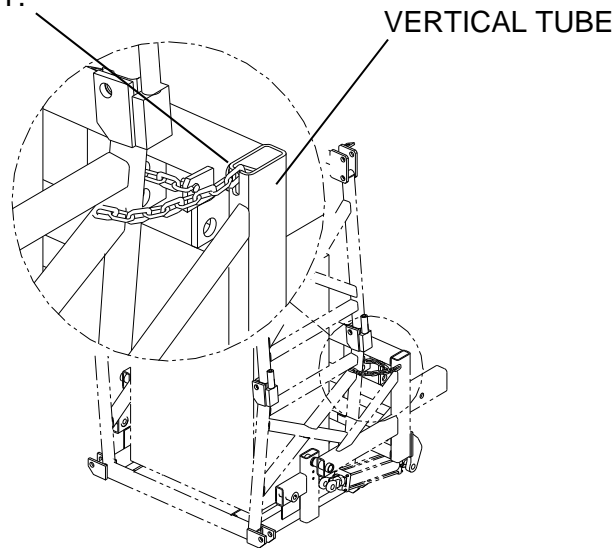

Figure 27

Lowering the system

When lowering the system, be sure that the Restraining Chain is placed in the "unlocked" position and that no person is behind the system. Then, press and hold the "Lower" side of the Rocker Switch.

Maintenance

Before performing any Maintenance on the SS90^{TMHD} TMA, thoroughly read and understand the Maintenance Section and the Safety Section of this Manual. If maintenance is to be performed with the system in the vertical ("up") position, be sure to secure the system with the Retaining Chain.

I. Routine Maintenance

Description	Interval
-------------	----------

<p>1. Height and Levelness - The height and levelness of the system is important to its impact performance. Check regularly and adjust as necessary (See Figure 28).</p>	<p>A/R*</p>
---	-------------

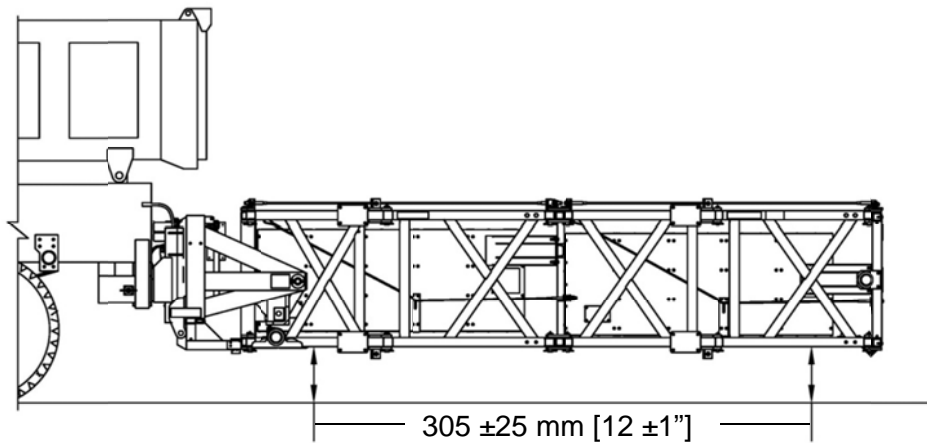

Figure 28

<p>2. Fasteners - Check the tightness of the fasteners monthly. See the drawings for the locations of the fasteners. Be sure to check bolts attaching the Cartridges to the Support Structure. Lock washers should be fully compressed.</p>	<p>1 Month</p>
--	----------------

<p>3. Hydraulic Cylinders, Hoses and Fittings - Inspect all hydraulic lines and connections for leaks. If the TMA sits overnight, check the ground underneath for fluid drip spots.</p>	<p>Each use</p>
--	-----------------

<p>4. Cables - Check the tension in the Cartridge Support Cables. With the system in the horizontal position, tighten the first nut on one cable until all the slack has been removed. Then tighten until the tension springs have been compressed to 1 1/4 ± 1/16 " in height. Lock this nut in place with the second jam nut. Repeat this procedure with the other cables. Check and adjust monthly or when loose (See Figure 22 on Page 22).</p>	<p>1 Month or when loose</p>
--	------------------------------

<p>5. Jacks - Check the condition of the wheels on the Jacks monthly or as required.</p>	<p>1 Month</p>
---	----------------

<p>6. Light Bulbs - Replace the light bulbs as required.</p>	<p>A/R*</p>
---	-------------

*A/R = as required

Description

7. Pins - Check all pins. Prior to each use, check all pins to make sure they are held in position by a retaining pin as required (See Figure 29).(34 places)

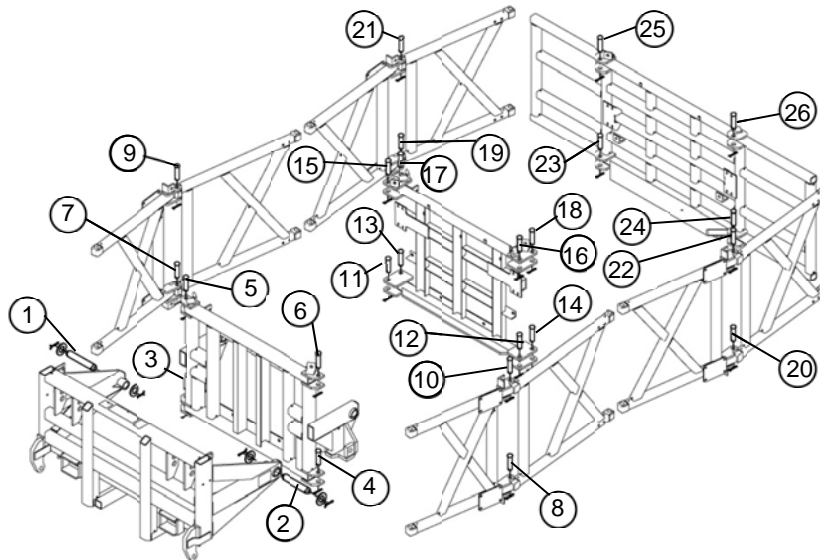

**Figure 29
(34 Pin Locations)**

Interval

Each use

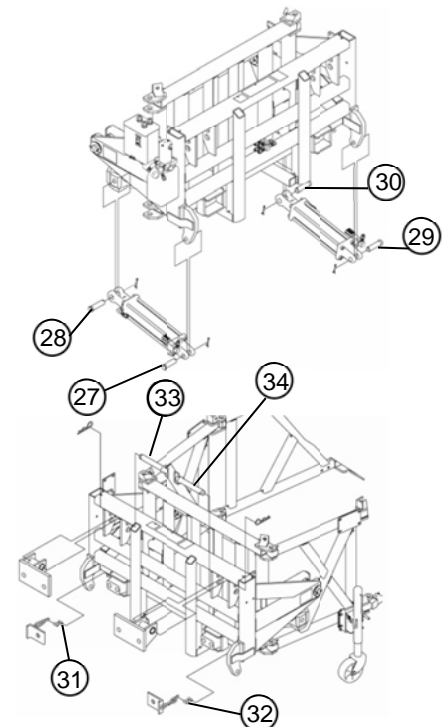

9. Clean System - Clean the Frame Assembly, Cartridges and Support Structure and Impact Face from dirt and salt as required. Check monthly. The system can be cleaned with mild soap solution. Always check lubrication after cleaning.

Varies— see Section IV

10 Hydraulic Pump - Clean the Hydraulic Pump as required. Check fluid level and electrical connections monthly. Remove all residue or debris on or around the Pump.

1 Month

11. Hydraulic Rams - Clean the Hydraulic Rams as required. Check monthly. Remove all residue or debris on or around the Rams.

1 Month

12. Lubrication - Lubricate as described in the Lubrication Section (Maintenance Section - IV) of this Manual.

1 Month

13. Grease Pins – Grease as described in the Grease Section (Maintenance Section – IV) of this Manual.

6 Months

14. System Check – Run the Hydraulic System up and down to make sure the Cylinder locks and buzzer is working.

Each Use

II. Hydraulic System Operation

Introduction

The SS90^{TMHD} TMA is equipped with a Hydraulic Locking system to allow the TMA to be locked in any position. This simplifies the design and operation of the TMA by eliminating the need for complex mechanical locking and unlocking mechanisms. It also makes raising and lowering of the system from the cab of the support vehicle much easier. The system works via two Hydraulic Solenoid Valves, one on each of the two Hydraulic Cylinders. These Solenoid Valves are electrically operated. When the TMA system is raised or lowered, these Valves are opened, allowing the hydraulic fluid to flow. At all other times, these Valves are closed, locking the TMA in place.



Warning: Never use the TMA as a crash cushion in any orientation that is not fully down. This can be dangerous because an errant vehicle may not properly engage the TMA. The system can only perform as a crash cushion when the system is in the all-the-way-down position. The SS90^{TMHD} TMA has an alarm which sounds when the TMA is not fully raised or lowered. Failure to follow this warning may result in damage, injury, or death.

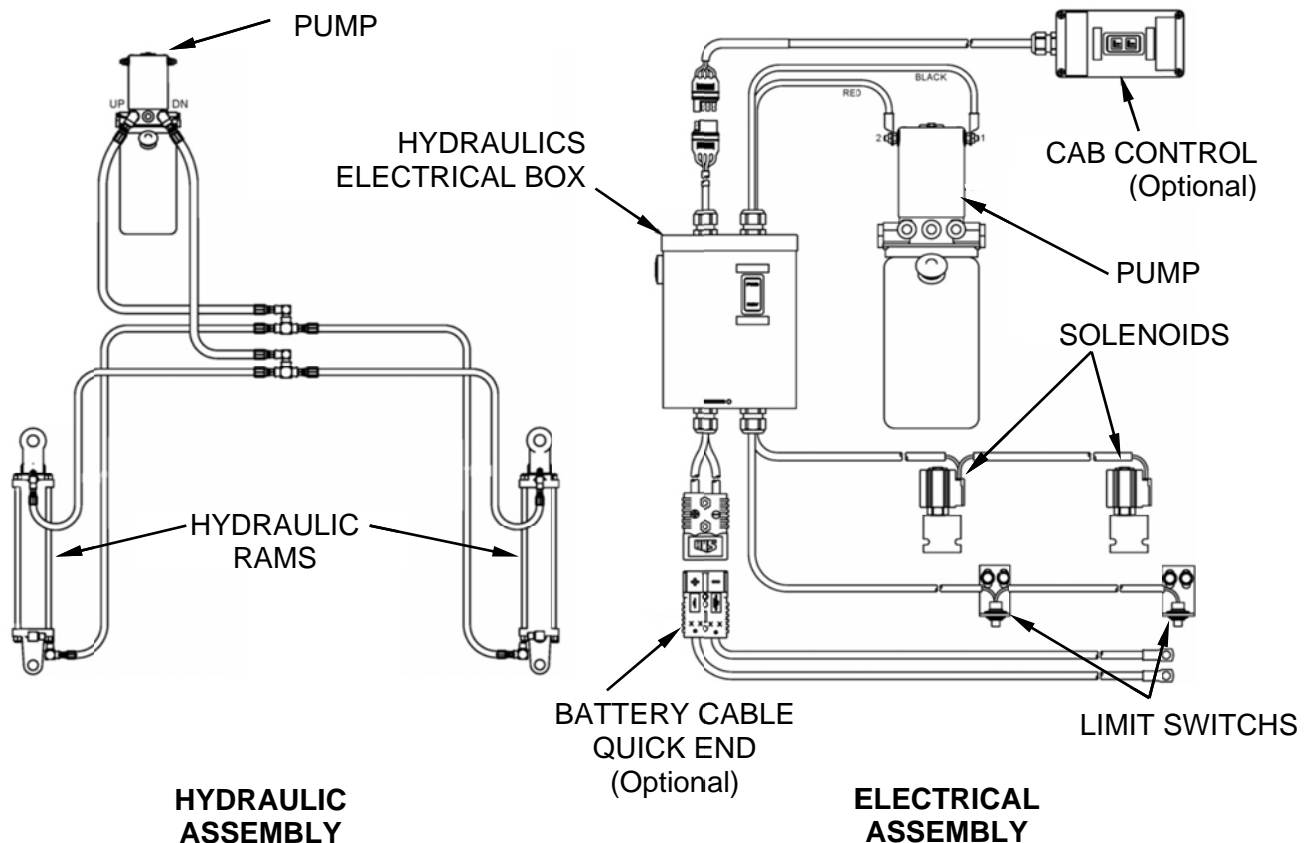

Figure 30

III. Detaching and Attaching the System to the Truck

1. Detaching the system from the truck

- A. Lower the system to the horizontal position.
- B. Remove the Jacks from the storage location and attach them to the system as shown in Figure 31.

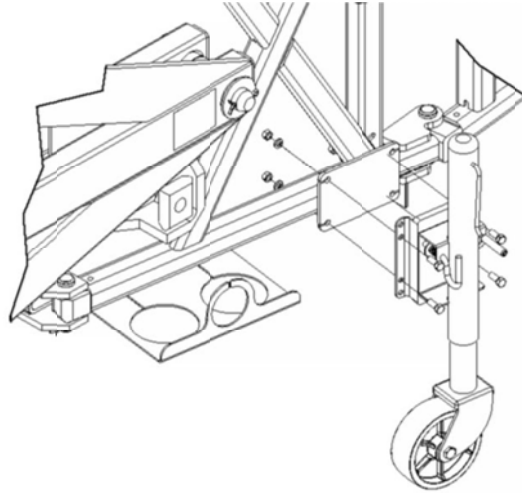

Figure 31

- C. Extend the Jacks until the system is supported.
- D. Unplug the Light Harness and disconnect the Positive Power and Ground Cables from the Pump. Remove the Cab Switch wires (optional) from the Control Box.
- E. Remove the Socket Hitches from the Underride Socket Receivers by removing 1 x 6 1/4" Hitch Pins and Retainer Pins*(See Figure 32).

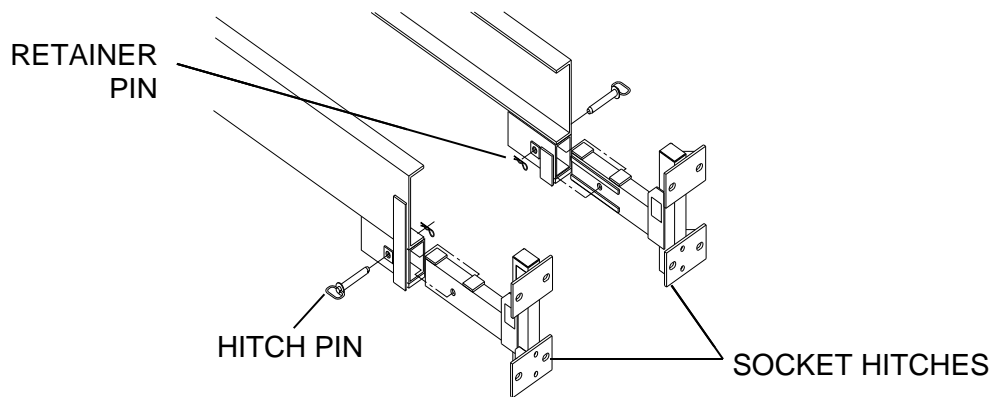

Figure 32

Note: If the alignment is off, making removal difficult, it may be necessary to adjust Jacks or temporarily disassemble the Attachment Brackets from the Socket Hitches. This can be done by removing the two 1 1/4 x 7" Hitch Pins and Retainer Pins and removing Anti-tilt Chains as shown in Figure 33 and 27.

***Reinsert Pins with Retainer Pins in Socket Hitches so they will not be lost.**

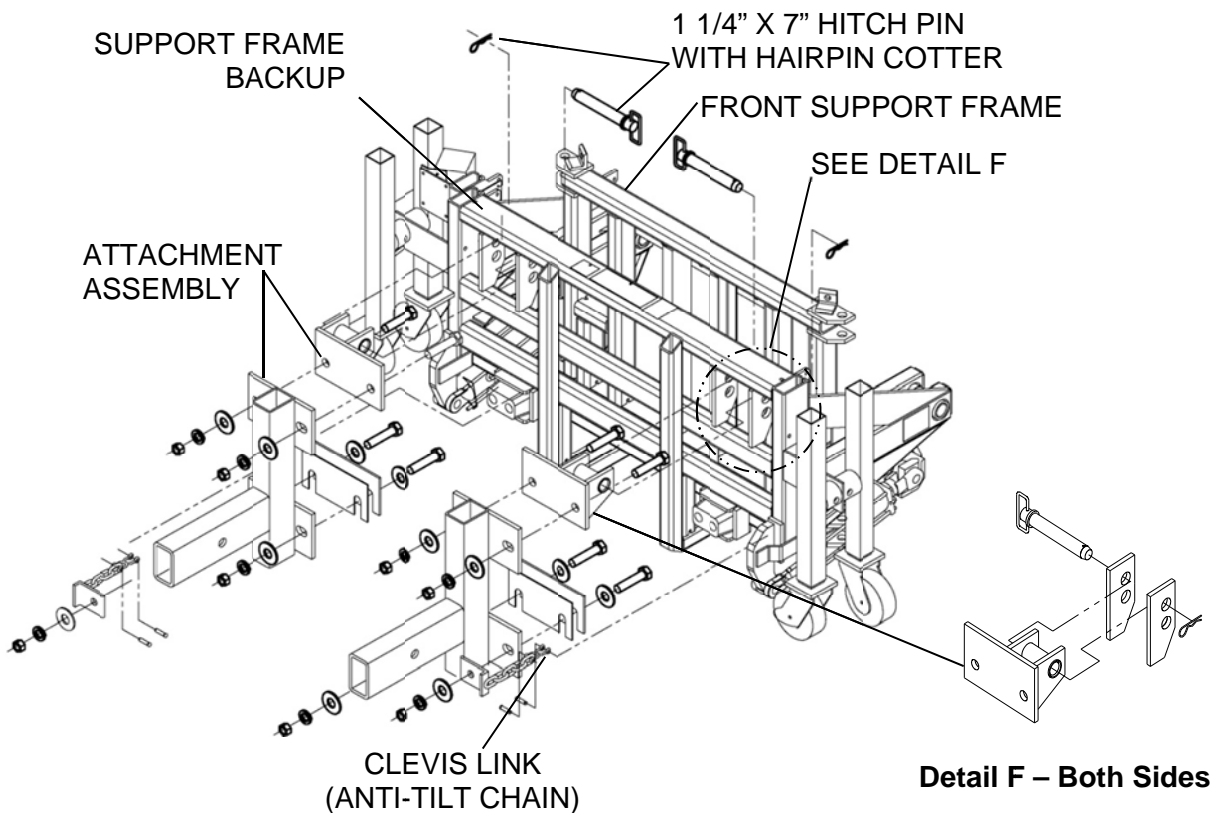

Figure 33

F. Move the TMA away from the truck.

2. Attaching the system to the truck

A. Move the TMA to the truck.

B. Insert the Socket Hitches into the Underride Socket Receivers and pin them into place using 1 X 6 1/4" Pin and Retainer Pin. If alignment is off, making the assembly difficult, it may be necessary to adjust Jacks or temporarily disassemble the Attachment Brackets from the Support Frame. Be sure the Retainer Pins are inserted correctly and cannot fall out.

C. Plug in the Light Harness and connect the Positive Power and Ground Cables to the Pump, and the Cab Switch wires (optional) to the Control Box.

D. Retract the Jacks completely and remove them to the storage position.

E. Check the Hydraulic/Electrical system for proper operation.

F. Verify that the system is level and 280-330 mm [11-13"] above the ground.

IV. Lubrication

1. Add Hydraulic Fluid

Add hydraulic fluid as required and check the fluid level monthly. The reservoir is full when the fluid level is close to the fill port. Use only Dexron® III Hydraulic fluid. Figure 34 shows the location of the hydraulic fluid fill port.



Caution: When handling hydraulic fluid, use appropriate measures to prevent spillage. Clean up spillage immediately.

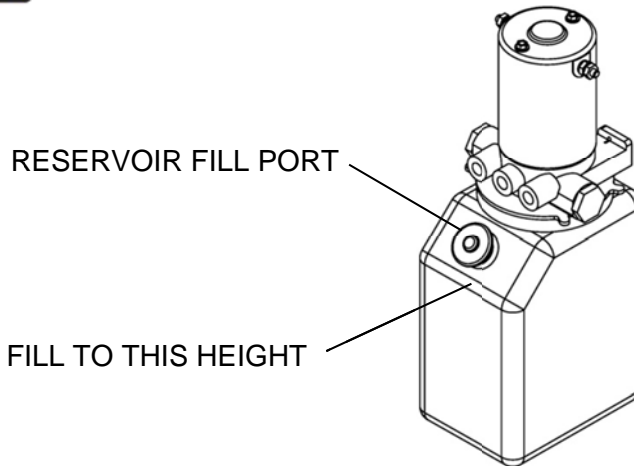
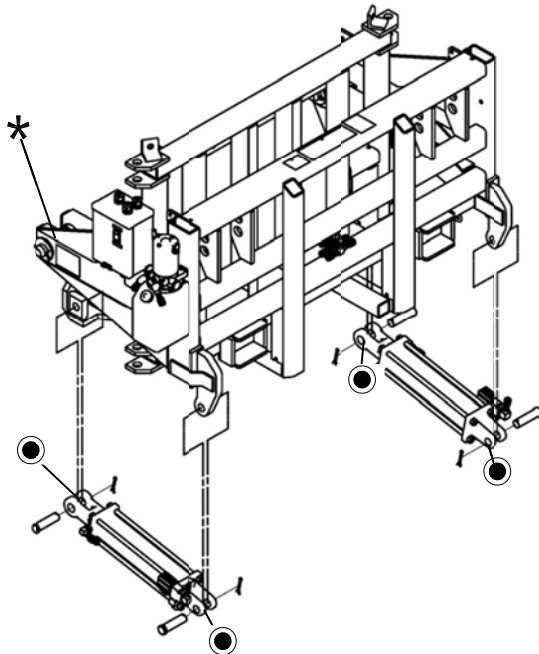

Figure 34

2. Grease Friction Points

Grease friction points (moving steel parts) every 6 months (See Figure 35).



- * GREASE THESE FRICTION POINTS USING BEARING GREASE
- GREASE THESE FRICTION POINTS USING LIGHT MACHINE OIL

Figure 35

3. Oil and Grease Swivel Jacks

Oil and grease the Swivel Jacks every six months as shown in Figure 36.

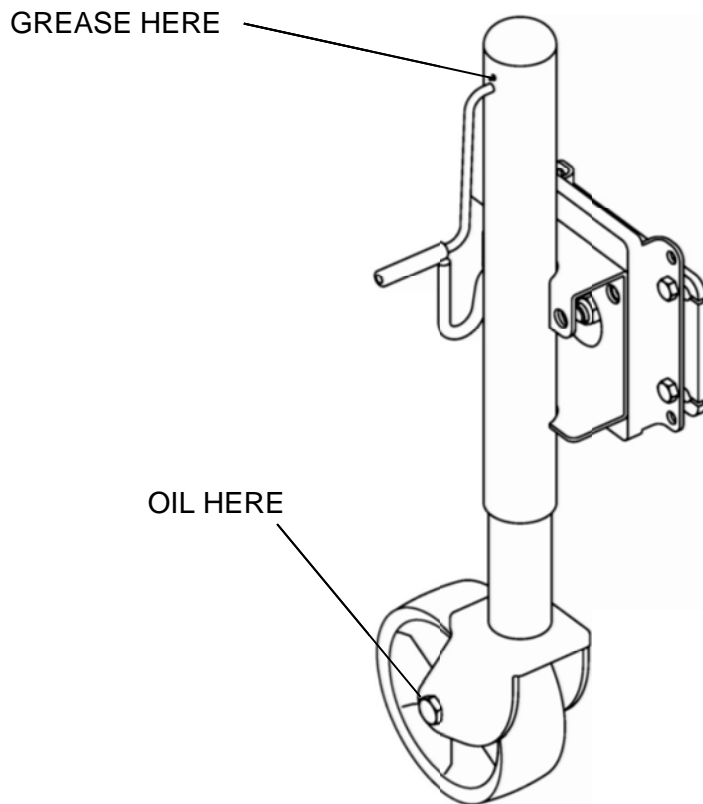

Figure 36

4. Change the Hydraulic Fluid

Change the hydraulic fluid every 2 years. Use only Dexron® III fluid. The Pump Reservoir capacity is 2 quarts.

The Pump Reservoir and system may need to be filled and cycled several times to remove air that may be trapped in the system. As the TMA is raised, the Pump will cavitate when the Reservoir is emptied. Add fluid until system rises to 90 degrees without cavitating. If this procedure is not followed, the Reservoir will overflow at the end of the bleed down cycle

V. Technical Specifications

1. Weight

Cartridge I	109 lbs	49 kg
Cartridge II	162 lbs	73 kg
Frame Components	1639 lbs	744 kg
Jacks	86 lbs	39 kg
Total	1996 lbs	905 kg

2. Dimensions (See Figures 37 & 38)

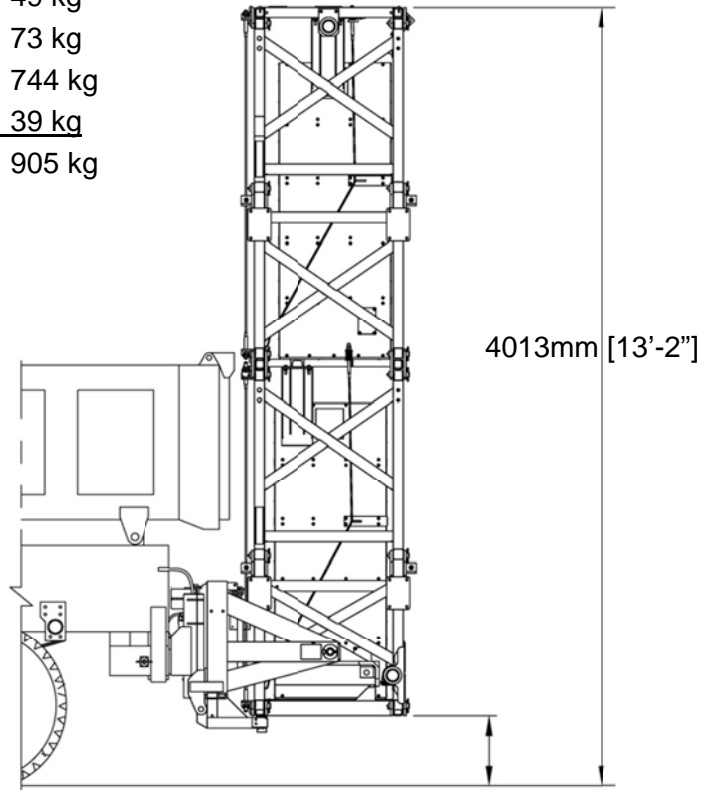

Figure 37

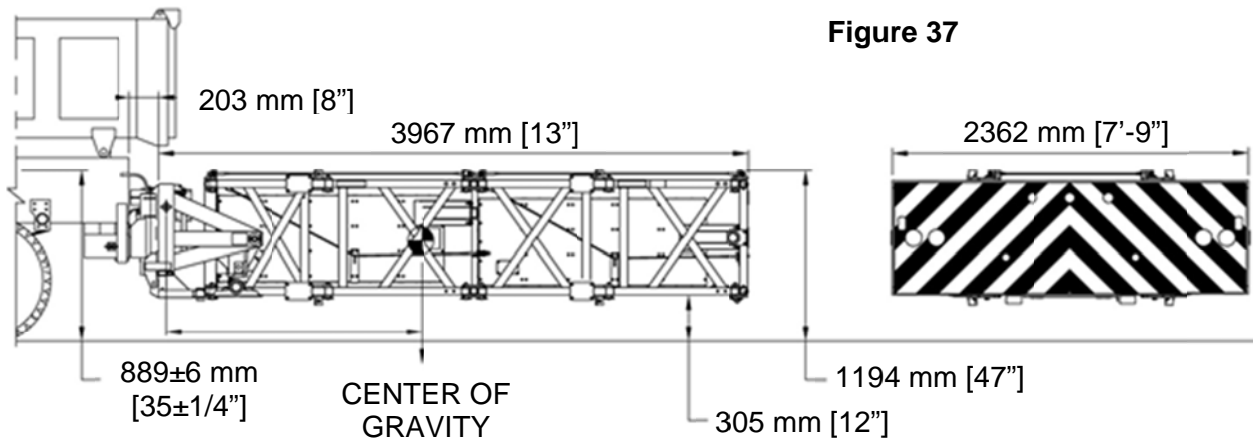

Figure 38

3. Replacement parts

For details on replacement parts, refer to the drawings at the end of the Manual. The drawings include the part numbers and descriptions. For replacement parts, call Customer Service (See Page 3).

4. Operating Rates

The system may be raised from the down to the up position in approximately 20 seconds. Lowering the system takes about 20 seconds as well.

Repair Instructions (Make a list of all damaged parts using part descriptions shown in Parts Lists, end of Troubleshooting section.)

IV. Post Impact



Important: Only the correct parts manufactured specifically for this product by Energy Absorption Systems may be used to repair a damaged system. Failure to comply may result in damage to the system and/or an untested effect on the impacting vehicle, to and including injury or death.



Caution: Be sure to use the Retaining Chain to lock the system while working behind or under the system in the raised position. Disconnect the power while work is being performed. Failure to comply may result in damage to the system, reduced safety, to and including injury or death.

1. Inspect the Frame for Bent Parts

Replace any Frame members that have been damaged. Do not attempt to weld or straighten parts. Replace the arms in pairs to ensure that the system collapses properly. Refer to the system drawings for the part numbers and descriptions of the parts.

2. Inspect Pins and Bolts for Damage

Replace all bolts and pins that have been damaged. Refer to the drawings at the end of the Manual for the part numbers and descriptions of the parts.

3. Expand the System and Loosen One End of the Top Cables

Extend the Frame and loosen one end of each of the four Top Cables.



Caution: Frames may swing side to side.

4. Remove Cartridges and Spent Release Cables



Important: Do not attempt to repair a damaged Cartridge. For full tested capacity, the Cartridges will need to be replaced even if they were only crushed slightly.

5. Inspect Corner Gussets for Damage

6. Attach the Bottom Release Cables Across the Arm Assemblies



Warning: For proper system performance, only use Release Cables supplied by Energy Absorption Systems. Failure to use the correct equipment could lead to fatigue or result in untested system performance.



Warning: Until the cables are inserted, the system may shift side to side.

Verify that the Frame is extended as far as it will go. Attach the Bottom Release Cable across Arm Assemblies (See Figure 39). Torque the nuts to $34 -0/+3$ N-m ($25 -0/+2$ ft-lbs) making sure that roughly an equal amount of threads protrude from nuts on both ends of Cable. Lock Cable in place using remaining fasteners as "jam" nuts.

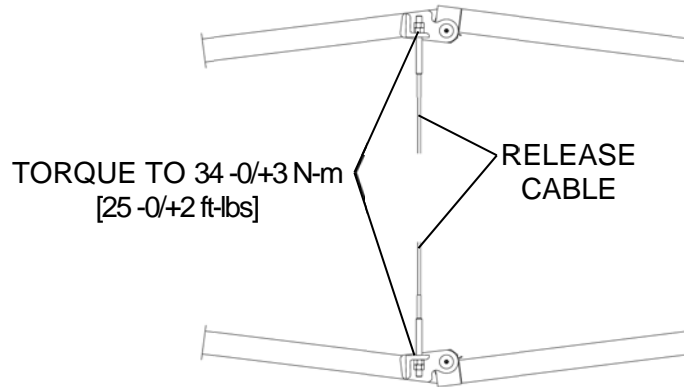

Figure 39

7. Attach Cartridges

Remove one end of each Alignment Cable from the TMA and set aside to clear the top side of each bay. Using a forklift and sling, place Cartridge I in position and secure it using the flat washers, lock washers, and nuts provided. Torque the nuts to 120 ± 7 N-m [90 ± 5 ft-lbs.] Repeat procedure for Cartridge II (See Figure 40).

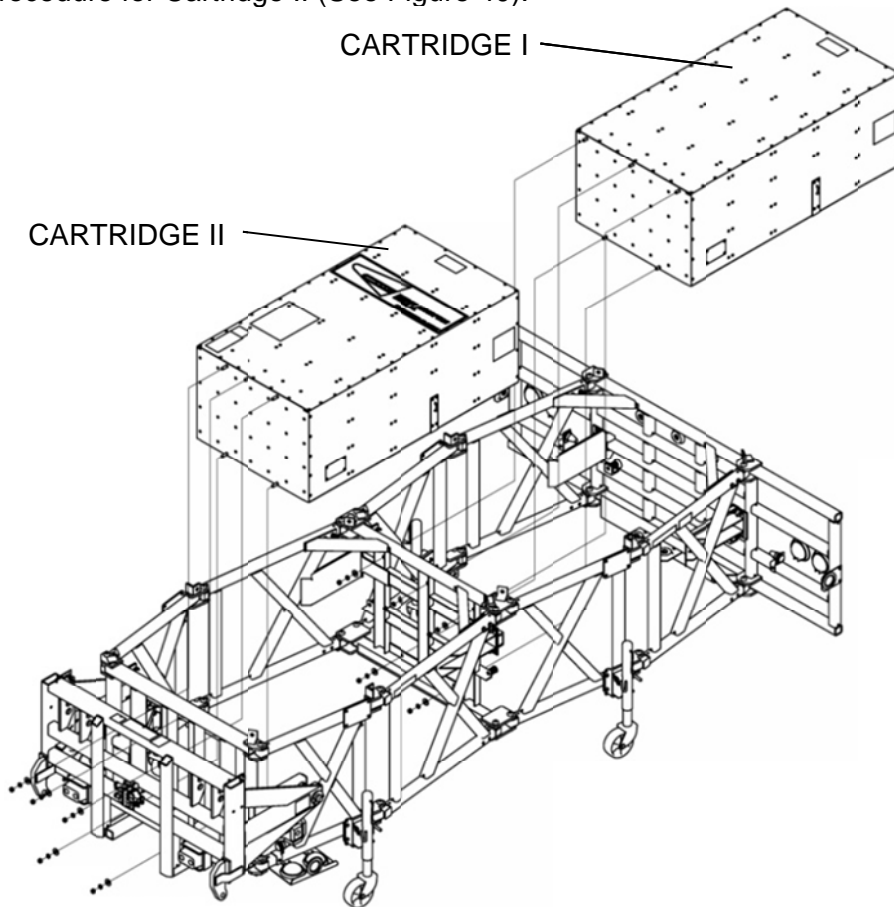

Figure 40

8. Attach the Top Release Cables across the Arm Assemblies

Attach the Top Release Cable across the Arm Assemblies (see Figure 39). Torque the nuts to 34 $-0/+3$ N-m (25 $-0/+2$ ft-lbs), making sure that roughly an equal amount of threads protrude from nuts on both ends of cable. Lock cable in place using remaining fasteners as "jam" nuts.

9. Reattach and Adjust the Alignment Cables

There are four Top Cables (two for each bay). Reattach the Alignment Cables as shown in Figure 41. Measure the diagonals of each bay and adjust the Cables so that the diagonal measurements in each bay are the same ($A = B \pm 5$ mm [$3/16$ "], $C = D \pm 5$ mm [$3/16$ "]). Lock each Cable in place using the second nut as a "jam nut" (See Detail 41A).

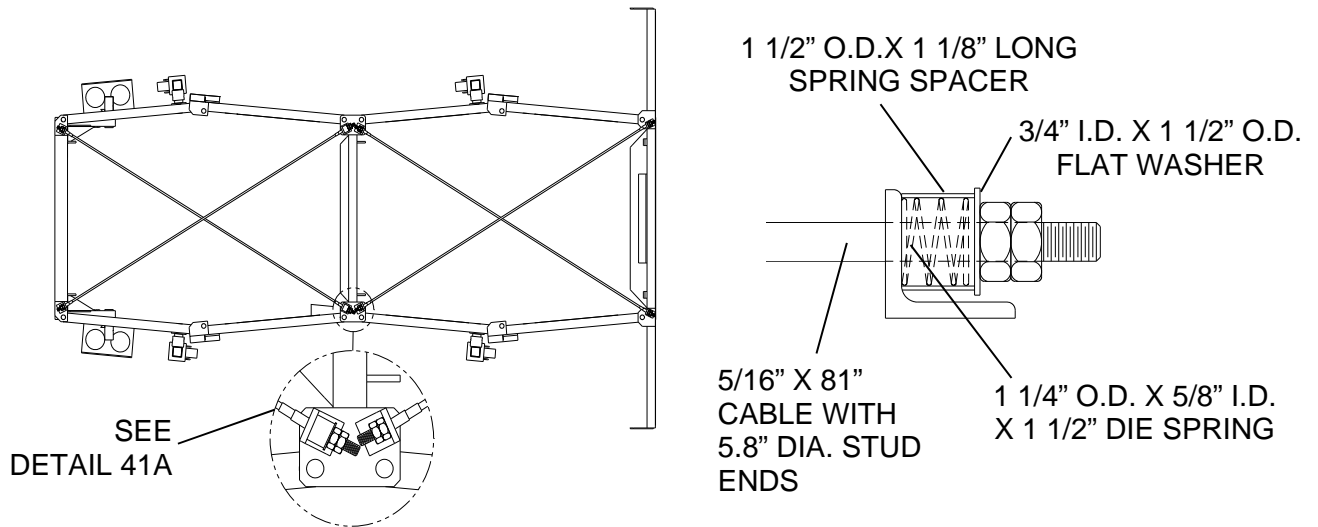

Figure 41 (Support Frame not shown for clarity)

Detail 41A

10. Replace Side Guides

The Side-Guides must be inspected and replaced if damaged. The Side-Guides are sacrificial and can be easily attached to their respective mounts. Side-Guides are necessary for proper system alignment during an impact and must be in place to ensure tested performance characteristics during system operation in an impact.

11. Attach and Tension the Cartridge Support Cables

There are four Cartridge Support Cables. Attach thimble end of all Cartridge Support Cables to the Frame as shown using the provided shackles. Pass the stud end of the cable through the corresponding Cartridge chain loop and attach as shown in Figure 42 using a die spring, washer, and nuts.

To properly tension the Cartridge Support Cables, lower the SS90™HD TMA to the horizontal position. Tighten the first nut on one Cable until all slack is removed, then tighten it until the Tensioning Springs have been compressed to 32±2 mm [1 1/4±1/16"]. Lock this nut in place with the second "jam" nut. Repeat this procedure with other Cables.

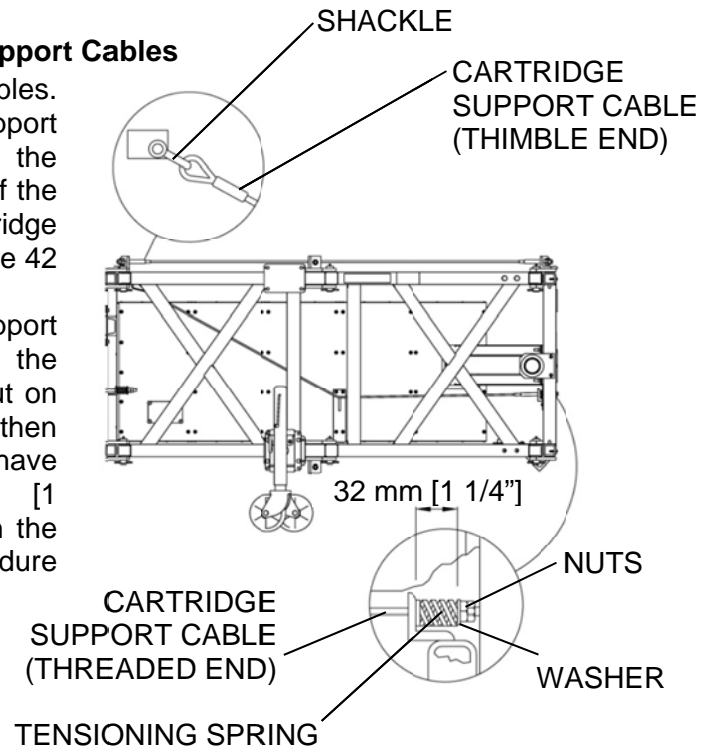

Figure 42

12. Adjust the Height and Levelness of the System Frame

Retract Jacks slightly off ground. Verify that the System Frame is 305 ± 25 mm [12" ± 1"] from the ground at the front and rear of the system. It may be necessary to place Shims under the Lower Attachment Bracket on the Frame Support in order to adjust the levelness of the Cartridge (See Figure 43).

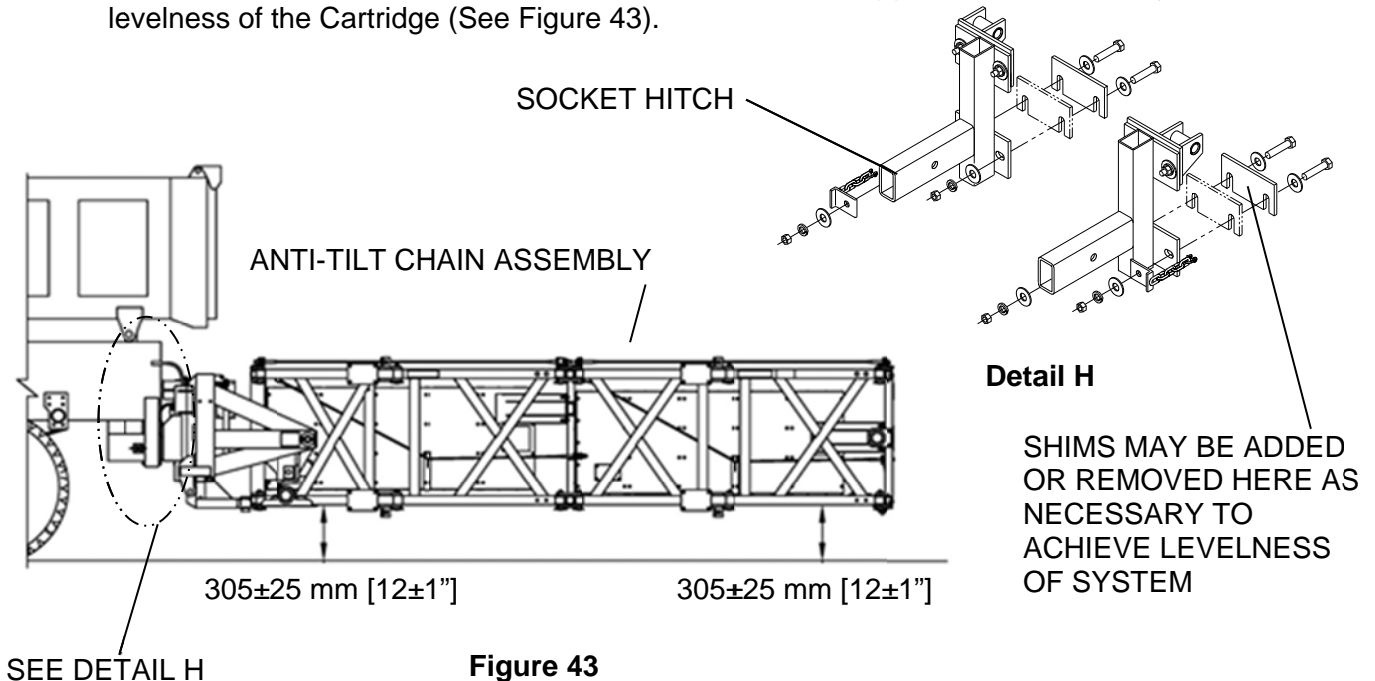

Figure 43

13. Reconnect Power Connections

Reconnect power and ground cables from battery.

14. Check System Lights for Proper Operation

Verify that all the turn/stop/tail lights are working properly. Replace any bulbs that are out.

15. Verify Position of Hydraulic/Electric Lines

Check the location of all the hydraulic and electrical lines to make sure they will not be damaged during the tilting of the system up or down.

16. Final Check

Check the tightness of all the fasteners. Check all steel cables to verify that they are properly attached and tightened.

17. Ready to Use

The system is now ready for use.

Troubleshooting Guide

(Make a list of all damaged parts using part descriptions shown in Parts Lists, end of Troubleshooting section.)



Caution: Always wear eye protection when working on or around machinery or power tools, and while working with hydraulics. Failure to follow these warnings and cautions could result in serious injury or death.



Danger: Do not attempt to control a hydraulic leak with your hand. High-pressure hydraulic fluid can puncture the skin and cause severe injury or death. Use extreme caution when working on hydraulic systems.

In general, consult Energy Absorption Systems Customer Service Department if problems associated with operating or repairing the TMA should arise. This guide is meant to be an aid for performing system maintenance, not a detailed repair manual. NOTE: For any problems not listed here, contact Energy Absorption Systems. If you suspect problems, **do not operate the system**. Diagnose and repair, or contact Energy Absorption Systems Customer Service Department for assistance.

Test Equipment

The following is a recommended list of test equipment required to troubleshoot D.C. powered hydraulic systems.

1. Pressure Gauge

A 34,450 kPa [5000 psi] pressure gage, preferably glycerin filled, is a valuable and relatively inexpensive tool for checking pressure in the various sections of the circuit.

2. D.C. Test Light

A test light is a light bulb with one lead wired to an alligator clip and the other lead connected to a metal probe. It is used to check for the presence of a voltage in the electrical circuit. With the alligator clip grounded, the light glows when the probe comes into contact with a hot electrical component.

3. Continuity Light

A continuity light is like a test light but contains its own battery. It is used for testing electrical circuits when the components are not connected to a power source.

4. Volt Meter

A D.C. voltmeter can be used to troubleshoot voltage problems. Two common uses are: 1) Ground one probe while using the other to probe hot leads in search of the available voltage at the point where the second probe is connected. 2) Measure a voltage drop in a wire or component by connecting one probe to one end and the remaining probe to the other end of the item in question.

5. Ohmmeter

An ohmmeter is used to measure resistance and is useful when working with solenoid coils. On some coils the wire resistance is large enough that a D.C. test light might not illuminate, falsely indicating an open circuit (infinite resistance). A successful coil test, however, should always show some non-infinite value of resistance.



Caution: All tests conducted with an Ohmmeter must be done with the power source disconnected from the system.

6. Assorted Hoses and Pressure Fittings

These can be used to connect and/or isolate certain parts of a hydraulic circuit for diagnosing hydraulic problems.

7. High Pressure Shutoff Valve

A shutoff valve can be used to choke off fluid flow so that a "false" load can be put on the pump and other components. With the valve attached, it can be slowly shut off while the equipment listed above records the data for making a proper diagnosis.

Hydraulic Fluid

1. THE PURPOSE OF HYDRAULIC FLUID

The main purpose of hydraulic fluid is to transfer power from the pump to the actuators but it must also perform many other tasks which are critical to a well-designed system.

First, the fluid must have good lubricity or be "slippery" so that the friction will be as low as possible to keep metal to metal wearing at a minimum. Second, the viscosity or "thickness" must be in the proper range at the operating temperature so that unwanted leakage will be at a minimum but will still allow the fluid to lubricate the close fitting parts in the system. (Fluid that is too thin will leak past seals, valve spools, and the gears; fluid that is too thick will not flow properly and cause the pump to cavitate or starve.) Third, the fluid must be compatible with the seals used in the system. Fourth, there should also be additives in the fluid to slow down the effects of rust, oxidation (oxygen in the air combining with the fluid to form sludge) foaming, and water settling to the bottom of the reservoir. Fifth, the fluid must be able to pour or flow at the lowest expected temperature so that the fluid can reach or get into the pump.

For all of the reasons listed above, automatic transmission fluid (ATF, Dexron III) was found in most cases to be the best readily available fluid for the job in most climate conditions.

2. SELECTING FLUIDS FOR APPLICATIONS OUTSIDE ATF'S TEMPERATURE RANGE

When looking for fluids that can be used in place of ATF or for applications where the operating temperature is outside the range of ATF, the following specs should be discussed with your local oil distributor:

- A. Fluid must be compatible with Buna-N sealing compounds.
- B. The Pour Point must be below the lowest anticipated temperature that will be encountered.
- C. It should contain Rust or Oxidation inhibitors as well as other detergent type inhibitors.
- D. The viscosity (SUS) should lie between 80 and 375 in the operating range, with the ideal viscosity near 200 SUS.
- E. The viscosity index should be as high as possible. As an example, ATF has the following specs as listed by most oil manufacturers:

[1] Viscosity (SUS)

37 deg. C [100 deg. F] 185 to 205

99 deg. C [210 deg. F] 45 to 55

[2] Pour Point

-44 deg. C [-45 deg. F] to -37 deg. C [-35 deg. F]

[3] Viscosity Index 145 to 165

NOTE: In an emergency, for cold weather applications, it is permissible to use SAE 10 W non-detergent oil mixed by volume with no more than 30% #1 fuel oil or kerosene. Afterward, flush system and add fluid as outlined above.

Pump Priming

1. New Assemblies

New system assemblies, as well as those that are disassembled for repair, require proper priming to avoid possible pump failure. A pump is said to be "primed" when the internal cavity is full of fluid and the air has been expelled.

A. Prime a pump as follows:

1. "Crack" or remove the high pressure line at or near the cylinder.
2. "Jog" the unit until fluid flow is clear.
3. Retighten or replace hose.

2. If a system fails to prime or loses its prime, check for the following:

- A. Partially clogged suction filter (see Filter section).
- B. A loose or improperly installed suction hose or pickup tube.
- C. Bad front pump seal (see Pump section).
- D. A solid fill plug in reservoir with no vent (see Reservoir section)
- E. Fluid that is too thick (see Hydraulic fluid section) or contaminated with water (see Reservoir section).
- F. Occasionally a pump will not prime itself because a check valve spring in the high pressure port is too "stiff" or the spring retainer is turned down too far. If this condition is suspected, loosen the spring retainer (found in the high pressure outlet port), energize the pump to prime it, and then turn the retainer back to the correct depth (see section on Check Valves).

Reservoirs

1. Use Recommended Fluid

Fill Reservoir with Dexron III ATF (See Hydraulic Fluid section on Page 43).

2. Filling and Operation

- A. Fill reservoir to within 12.5 mm [1/2"] with all the cylinders in the fully retracted position.
- B. Operate system several times starting with short cylinder strokes and increasing length of each successive stroke.
- C. Recheck fluid level often and add fluid as necessary to keep pump from picking up air.
- D. After system is completely "bled", collapse all cylinders, check fluid level in reservoir, and attach the filter/breather plug provided.



Caution: Do not use a solid plug or fill cap without a filter/breather element: damage will be caused to the pump and/or reservoir.

3. Reservoir Problems

- A. Clear fluid flowing out of fill hole usually means Cylinders were not fully collapsed when reservoir was filled.
- B. Foamy fluid flowing out of the fill hole points to the following:
 - 1. Air is present in the system; that is, cylinders and fluid lines. The response usually is "spongy" and the cylinder moves with a "jerking" motion.
 - 2. There is no drop tube or "down spout" on the return line so that the fluid is not returning to the bottom of the reservoir.
 - 3. Damage to pump seal (See Pump Priming Section on Page 44).
- C. Water in the fluid.

Water can enter the reservoir through the fill hole if the unit is left outdoors or washed with high pressure washers. Protect the unit, whenever possible, and change fluid regularly to minimize problems. In cold weather the water will freeze and the pump will not work until the ice melts.

Filters

Most pump systems have filters which must be cleaned periodically or whenever flow is slow or sluggish. Some filters may be washed in cleaning solvent and blown dry with compressed air. Those which cannot be cleaned sufficiently should be replaced. External high pressure filters may be added to the system for added protection and ease of cleaning.

Hydraulic Cylinders

1. DIAGNOSING AND TROUBLESHOOTING HYDRAULIC CYLINDERS

- A. Most ram type failures are caused by one of the following reasons:
 - 1. Excessive side load.
 - 2. Stroking the rod to full extension.
- B. Excessive side load can be diagnosed by observing the following:
 - 1. Cracked gland nut.
 - 2. Gouged rod.
 - 3. A cracked or bent rod that will not retract back into the tube.
- C. Over-stroking can be diagnosed by observing the following:
 - 1. Premature leakage past the V-rings.
 - 2. System filters that become prematurely clogged with pieces of rubber due to v-ring crushing (See section on Filters).
- D. It is also possible to have a piston seat failure. This feature will show up as a cylinder drift in the hold position. Troubleshoot in the following manner:
 - 1. Put the cylinder in the hold position.
 - 2. Place a jack under the load.
 - 3. Remove the high pressure hose from the cylinder port on the side opposite the holding end.
 - 4. Let the jack down slowly: If the piston seal is bad, fluid will escape from the port.



Warning: Do not use a solid plug or fill cap without a filter/breather element: damage will be caused to the pump and/or reservoir.

2. REPAIRING HYDRAULIC CYLINDERS

- A. Remove cylinder from the assembly, disconnect hose line(s), and drain fluid.
- B. Remove gland nut, rod, spreader, and packing assembly from the tube assembly.
- C. Clean internal tube and inspect chrome rod for gouges, scratches, or wear. Replace if necessary.
- D. Replace chrome rod back into tube assembly.
- E. Insert steel spreader.
- F. Grease the v-ring set on the inside and outside diameters.
- G. Reattach one V-ring at a time, making sure each V-ring lies flat on the ring prior to it.
- H. Replace the gland nut complete with a new wiper ring if worn. Thread it down until it makes contact with the V-rings, then tighten an additional 1 to 1 1/2 turns. The distance between the top of the threaded collar and the bottom of the large section on gland nut should be 6.35 to 7.94 mm [1/4" to 5/16"]. Do not over tighten.



Important: If it is possible to stroke the cylinder after repairing, turn gland nut until it contacts the V-rings and stroke the cylinder to allow the rings to seat and align, then retighten as described above.

- I. Double acting cylinders have two piston cups on the internal threaded end of the chrome rod. If these cups are worn they must be replaced to ensure a proper seal. It is also advisable to check the piston "O" ring and the stuffing box "O" ring and replace if signs of wear exist.



Important: When replacing pistons on the rod, have the "O" ring well-greased and screw the piston past the threads to prevent damage to the new "O" ring.

- J. Replace the V-rings, spreader, and gland nut as described in E, F, G, & H, above.

Electrical Problems



Caution: Remove all rings, watches, etc. prior to doing any electrical work.

1. Operating D.C. Power Systems

Operating D.C. (direct current) power systems efficiently requires proper voltage. Any attempt to operate below the minimum required voltage could cause system failure.

- A. Signals which point to low voltages are:
 1. Motor running at reduced speed.
 2. Solenoid valves not shifting.
- B. Minimum voltage readings are as follows:
 1. The minimum voltage required for the Pump Motor to operate is 9.5 volts.
 2. The minimum voltage required for the solenoid valves to work is 9.5 volts.

- C. Causes for low voltage are:
1. Battery capacity too small.
 2. Cable ends not electrically secure to battery cable. (Solder them if necessary)
 3. Battery cable size too small for load and length of run. Copper #2 automotive battery cable is the recommended minimum size. Larger copper battery cable (#1, #0, or #00) may be required for cable lengths over 25 feet to keep performance from deteriorating.
 4. Bad joints where cable ends are bolted to battery, motor solenoid, start switch, ground, etc.
 5. Burnt contacts on motor solenoid or start switch.
- D. Check for low voltage as follows: (A volt meter will be required.)
1. On vehicles equipped with an alternator, the voltage should be approximately 13.5 volts with no electrical accessories operating and the engine running - Check it.
 2. Operate pump under maximum conditions. Use the volt meter to probe each connection, cable end, and cable from the battery all the way back to the motor stud and note the voltage losses. Make necessary repairs. Increase the voltage above the minimum required.



Important: Check the ground side as well: paint, rust, and dirt are insulators - remove them.

2. D.C. Motors

Motors should be serviced periodically to ensure good performance. Service as follows:

- A. Remove head assembly from motor.
- B. Check sleeve bearing in head assembly for wear.
- C. Place a few drops of fluid on felt liner in head assembly
- D. Check brushes for wear, and replace if necessary.
- E. Blow dirt and dust out of motor housing and check for shorts, burnt wires, or open circuits in the field coil assembly.
- F. Check armature and commutator for shorts or open circuits.
- G. Check ball bearing on motor shaft: A "growling" motor can be caused by bad bearings.
- H. Check for excessive "end play" of armature and add thrust washers as necessary.
- I. If there is an excessive amount of water, condensation, or rust in the motor, a small drain hole may be drilled in the motor case on the low side of the motor depending on the mounting - consult with pump manufacturer for additional information.



Important: A motor which does not turn in freezing weather could be caused by water that has frozen inside the housing.

- J. Be sure to check orientation of motor before replacing.
- K. If motor fails to turn the pump, check the pump by turning drive shaft by hand – the motor or the pump may be "seized up".

3. Electrical Circuits

- A. Push button, toggle, rocker, or manual motor start switches: Defective switches are a common cause of electrical malfunction. What SEEMS to be a serious system defect can often be caused simply by a faulty switch, especially where the switch controls two functions (e.g. start the motor, and shift a valve). In those cases, one half the switch might be defective, while the other half operates correctly and the fault appears to be with some other component.

Troubleshooting can be done by any one of three methods.

1. Use a continuity light to test switch. (See Test Equipment section)
2. Use a circuit test light to test switch. (See Test Equipment section)
3. Remove the wires from the switch and touch them together in the proper order to operate them.



Important: Even though external switch is "waterproof", any switch controls subject to the weather should be mounted so that the cord exits from the bottom to prevent water from entering the box.

- B. Motor start solenoid switches:

Although there may be exceptions, most solenoid switches found on TMA pumps are the following type: Three Post Solenoid Switch (See Figure below).

1. This three post solenoid switch is wired and constructed as follows:
 - a. The large post marked "Bat" must be attached to the cable leading from the battery.
 - b. The small post connects to the control circuit. (Push button, rocker, or toggle, etc.)
 - c. The shared "hot" lead from the control circuit must also be attached to the large post marked "Bat".
 - d. The remaining large post attaches to the cable leading to the motor.

4. Shorts, "Grounding Faults" and "Open Circuits"

In control wiring, shorts can only occur when "hot" lines (lines connected directly to the battery) come in contact with a ground. A short will either cause a fuse to blow, if there is a fuse, or burn the wire off at its weakest point. Likely spots for shorts are switches, electrical strain reliefs, electrical junction boxes, and a control cord which has been pinched or cut.

Grounding faults are much like shorts except they occur on the opposite side of the electrical component. A "ground fault" will cause the coil in the motor solenoid switch to remain energized. This type of failure can happen because switching is done in the ground wire due to the construction of the motor solenoid switch (See "3 - Electrical Switches, C - 1). Likely spots for "faults" are the same as for shorts - See above.

An "open" circuit is simply a break which prohibits current flow. Likely spots for "open" circuits are the same as shorts - See above.

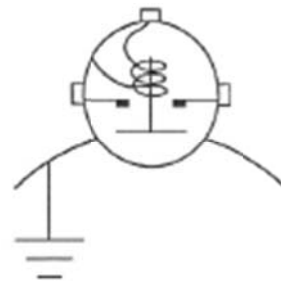

5. Solenoid Coils

Coils are used in solenoid operated valves and start switches. Failures can be caused by vibration, water, improper voltage, or corrosion. The best way to test a coil is with an ohmmeter. The meter should read some value of ohms. An infinite reading means that the coil has an open circuit. The reading between any lead on the coil and the "can" should be infinite unless there is only one lead wire and the coil is grounded to the "can".

6. Electrical Polarity

Pump motors supplied with TMA's can be used on either positive or negative ground systems.

Hydraulic Quick Troubleshooting Guide

Finding and Solving Problems:

Hydraulic system failures usually follow a similar pattern: A gradual or sudden loss of pressure or flow, followed by a loss of cylinder or motor power. Any of the systems components could be the cause. The problem may be solved by following a step by step procedure.

1. MOTOR FAILS TO START:

Failed motor starter solenoid: Replace if necessary.

Electrical switch inoperative: Repair or replace.

"Open" circuit/Insufficient grounding: Check and correct.

Motor inoperative: Repair or replace.

2. SYSTEM IS INOPERATIVE:

No fluid in system; insufficient fluid in system; pump losing prime: Fill system; Check for leaks.

Wrong fluid in system (Should be Dexron III): Change fluid.

Clogged or dirty filter: Drain fluid and replace filter or element.

Fluid line restricted: Line dirty or collapsed - Clean or replace fluid line.

Air leaks in pump suction line: Repair or replace as needed.

Worn or dirty pump: Clean, repair or replace; check alignment; check for contaminated fluid - drain, flush, and refill system with approved fluid

Badly worn components (valves, cylinders, etc.): Examine and test for internal or external leakage. Replace faulty components. Check for cause of wear.

Leakage: Check all components, especially the relief valve, for proper settings.

Excessive load: Check for binding. Do not allow extra weight on lowered Cartridge.

Broken pump drive: Repair or replace couplings, etc. Check for "Ground" fault.

3. SYSTEM OPERATES ERRATICALLY

Air in system: Check suction side for leaks. Repair.

Cold fluid: Allow system to warm up.

Damaged or dirty components: Clean or repair as needed.

Restricted lines or filters: Clean and /or replace lines or elements as necessary.

4. SYSTEM OPERATES SLOWLY

Fluid viscosity too high or cold fluid: Allow fluid to warm up before operating or replace fluid with proper specified fluid.

Low fluid level: Check reservoir & add fluid as necessary.

Air in system: Check suction side for leaks - repair; cycle system several times to relieve air from system.

Worn pump, valves, cylinders, etc: Replace or repair as necessary.

Restriction in lines or filters: Clean or replace elements or lines.

Improperly adjusted flow control valve: Replace or adjust as necessary.

Oil leaks: Tighten fittings; replace seals or damaged lines.

Low Voltage: Using volt meter and/or ohmmeter check system (See Electrical Problems section on Page 48). Check alternator; check connections.

5. FLUID IN SYSTEM OVERHEATS

Incorrect, low, or dirty fluid: Add or change fluid as necessary.

Excessive component internal leakage: Repair or replace as necessary.

Restriction in lines or filters: Clean or replace as needed.

Insufficient heat radiation: Clean dirt and mud from reservoir and components.

Malfunctioning component: Replace or repair.

6. FOAMING OF FLUID

Incorrect, low or dirty fluid: Replace or add fluid as needed.

Air leaks: Check suction lines & component seals for leaks. Replace.

7. NOISY PUMP

Low fluid level, incorrect or foamy fluid: Replace or add fluid as necessary.

Suction line or inlet screen plugged: Clean or replace.

Worn or damaged pump: Repair or replace.

8. LEAKY PUMP OR MOTOR

Damaged or worn shaft seal: Replace. Check for misalignment.

Loose or broken parts: Tighten or replace.

Incorrectly adjusted relief valve.

9. SYSTEM BLEEDS DOWN WHEN SYSTEM "LOCKED"

Leaking cylinder seals or fittings: Replace worn or damaged parts.

10. LEAKY CYLINDER(S)

Seals worn or damaged: Replace.

Rod damaged: Replace.



Danger: Never stand behind or in the path of the TMA when it is being raised, lowered, or someone is at the controls.

PARTS LIST		
ITEM	STOCK NO.	DESCRIPTION
1	614467B	SOCKET RECEIVER, UNDERRIDE, L
2	614472B	SOCKET RECEIVER, UNDERRIDE, R
3	611413B	MOUNT SUPPORT, TMA, L
4	611413B	MOUNT SUPPORT, TMA, R
5	116295G	PIN, HITCH, 1X6 1/4, W/SNAP PIN
6	617780B	TUBE, SPACER
7	614590B	SPLICE, SPACER
8	605506B	BRACKET, LOWER TRUCK, W/HOLES
9	116104B	PAINT BLACK, ENAMEL, GLOSS, SPRAY
10	115252B	INSTALL INST. RECEIVER UNDERRIDE
11	116505G	PRIMER, SPRAY CAN

USE AS RECD
USE AS RECD

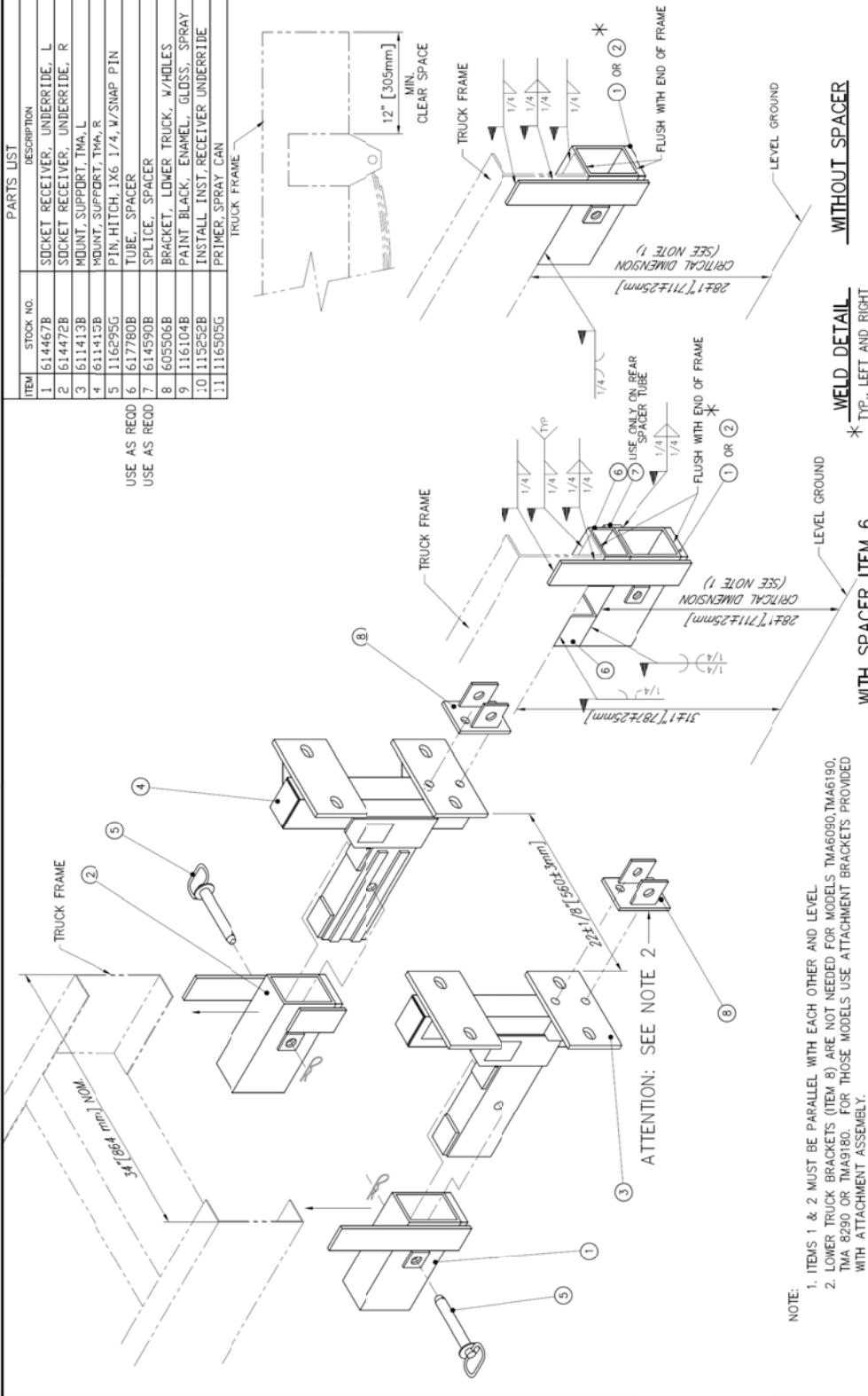

NOTE:
1. ITEMS 1 & 2 MUST BE PARALLEL WITH EACH OTHER AND LEVEL.
2. LOWER TRUCK BRACKETS (ITEM 8) ARE NOT NEEDED FOR MODELS TMA6090, TMA6190, TMA 8290 OR TMA9180. FOR THOSE MODELS USE ATTACHMENT BRACKETS PROVIDED WITH ATTACHMENT ASSEMBLY.

Revisions	Date	Rev. By	Des. By	Drawn	Checked	Appr.	DATE
ADDED NOTE 1	8/5/94	A	KM	STI	SP/ML	Bob Seebing	08/25/93
ADDED ITEM 10, 2159531-0000	10/01/94	B	STI	KM	SP/ML	Chris Seebing	09/30/93
REMOVED NOTE 2 AND ITEM 11	1/7/94	C	STI	KM	SP/ML	B. Jones	08/18/94
ADDED DIMENSIONS TO ITEMS 3 & 4	06/20/91	E	PCG	BB	SP/STI	O.C.	09/30/93
ADDED DIMENSIONS TO ITEMS 3 & 4	11/28/00	F	LWS	BK	KM/STI	J. M. Thompson	09/30/93
ITEM 5 WAS 2102221-0000	11/28/00	G	LWS	BK	KM/STI		
Added TMA8290 AND 9180 TO NOTE 2	11/01/02	H	LWS	PK	PK		
Removed TYP, weld callout, Item 1 to 6	8/15/08	H	WML	PK	PK		
Added ROMACS (Wm 3524420-0000)	11/11/11	H	STI	PK	PK		

REFERENCES

SEE PART DRAWINGS

WELD DETAIL

* TYP., LEFT AND RIGHT (LEFT SHOWN)

WITHOUT SPACER

ASSEMBLY NO. 616797B

ENERGY ABSORPTION SYSTEMS, INC. ENGINEERING AND RESEARCH DEPARTMENT	
UNDERRIDE ASSY, RECEIVER, TMA	
SCALE (1:8)	SIZE (1/8"=1")
DWG. NUMBER	616797
SHEET	1 OF 1
REV	H

DWG 616797

Underride Assembly, Receiver, TMA

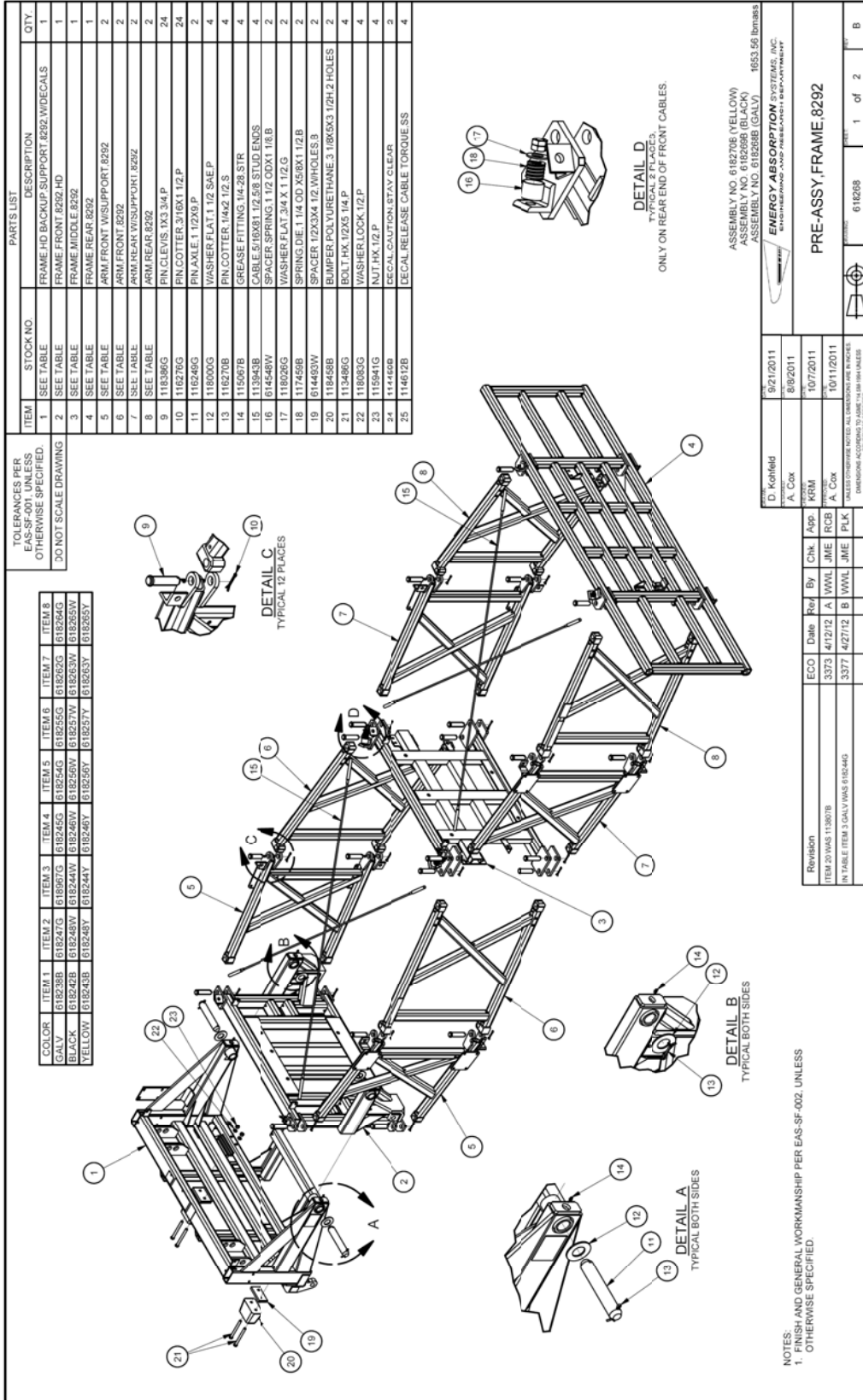

TOLERANCES PER
DRAWING UNLESS
OTHERWISE SPECIFIED.
DO NOT SCALE DRAWING

ITEM	STOCK NO.	DESCRIPTION	QTY
1	SEE TABLE	FRAME HD BACKUP SUPPORT 8292, W/DECALS	1
2	SEE TABLE	FRAME FRONT 8292, HD	1
3	SEE TABLE	FRAME MIDDLE 8292	1
4	SEE TABLE	FRAME REAR 8292	1
5	SEE TABLE	ARM FRONT W/SUPPORT 8292	2
6	SEE TABLE	ARM REAR W/SUPPORT 8292	2
7	SEE TABLE	ARM FRONT 8292	2
8	SEE TABLE	ARM REAR 8292	2
9	11836G	PIN CLEVIS 1X3 3/4 P	34
10	11627G	PIN COTTER 3/16X1 1/2 P	24
11	11624G	PIN AXLE 1 1/2X3 P	2
12	11800G	WASHER FLAT 1 1/2 SAE P	4
13	11627B	PIN COTTER 1/4X2 1/2 S	4
14	11507B	GREASE FITTING 1/4-28 STR	4
15	11394B	CABLE 6/16X81 1/2, 5/8 STUD ENDS	4
16	61454W	SPACER SPRING 1 1/2 ODX 1 1/8 B	2
17	11802G	WASHER FLAT 3/4 X 1 1/2 G	2
18	11745B	SPRING DIE 1 1/4 OD X 5/8X1 1/2 B	2
19	514403W	SPACER 1/2X3/4 1/2 WHOLE S B	2
20	11845B	BUMPER POLYURETHANE 3 1/8X5X3 1/2H 2 HOLES	2
21	11348G	BOLT THX 1/2X 1/4 P	4
22	11805G	WASHER LOCK 1/2 P	4
23	115941G	NUT THX 1/2 P	4
24	114460B	DECAL CAUTION STAY CLEAR	2
25	114612B	DECAL RELEASE CABLE TORQUE SS	4

COLOR	ITEM 1	ITEM 2	ITEM 3	ITEM 4	ITEM 5	ITEM 6	ITEM 7	ITEM 8
GALV	618238B	618247G	618957G	618245G	618254G	618255G	618262G	618264G
BLACK	618242B	618248W	618244W	618246W	618250W	618257W	618263W	618265W
YELLOW	618243B	618249Y	618244Y	618246Y	618250Y	618257Y	618263Y	618265Y

ASSEMBLY NO. 6182706 (YELLOW)
ASSEMBLY NO. 6182696 (BLACK)
ASSEMBLY NO. 6182686 (GALV) 1653 56 lbmats

ENERGY ABSORPTION SYSTEMS, INC.
1653 56 lbmats

PRE-ASSY, FRAME, 8292

DATE: 9/21/2011
BY: D. Kohfeld
APP: A. Cox

DATE: 8/9/2011
BY: KRM
APP: RCB

DATE: 10/7/2011
BY: A. Cox
APP: PLK

REVISIONS PER EAS-SF-002

REVISION: 1
DATE: 4/27/12
BY: WJM
APP: JME

REVISION: 2
DATE: 4/27/12
BY: WJM
APP: JME

REVISION: 3
DATE: 4/27/12
BY: WJM
APP: JME

REVISION: 4
DATE: 4/27/12
BY: WJM
APP: JME

REVISION: 5
DATE: 4/27/12
BY: WJM
APP: JME

REVISION: 6
DATE: 4/27/12
BY: WJM
APP: JME

REVISION: 7
DATE: 4/27/12
BY: WJM
APP: JME

REVISION: 8
DATE: 4/27/12
BY: WJM
APP: JME

REVISION: 9
DATE: 4/27/12
BY: WJM
APP: JME

REVISION: 10
DATE: 4/27/12
BY: WJM
APP: JME

REVISION: 11
DATE: 4/27/12
BY: WJM
APP: JME

REVISION: 12
DATE: 4/27/12
BY: WJM
APP: JME

REVISION: 13
DATE: 4/27/12
BY: WJM
APP: JME

REVISION: 14
DATE: 4/27/12
BY: WJM
APP: JME

REVISION: 15
DATE: 4/27/12
BY: WJM
APP: JME

REVISION: 16
DATE: 4/27/12
BY: WJM
APP: JME

REVISION: 17
DATE: 4/27/12
BY: WJM
APP: JME

REVISION: 18
DATE: 4/27/12
BY: WJM
APP: JME

REVISION: 19
DATE: 4/27/12
BY: WJM
APP: JME

REVISION: 20
DATE: 4/27/12
BY: WJM
APP: JME

REVISION: 21
DATE: 4/27/12
BY: WJM
APP: JME

REVISION: 22
DATE: 4/27/12
BY: WJM
APP: JME

REVISION: 23
DATE: 4/27/12
BY: WJM
APP: JME

REVISION: 24
DATE: 4/27/12
BY: WJM
APP: JME

REVISION: 25
DATE: 4/27/12
BY: WJM
APP: JME

DWG 618268 Sheet 1 of 2

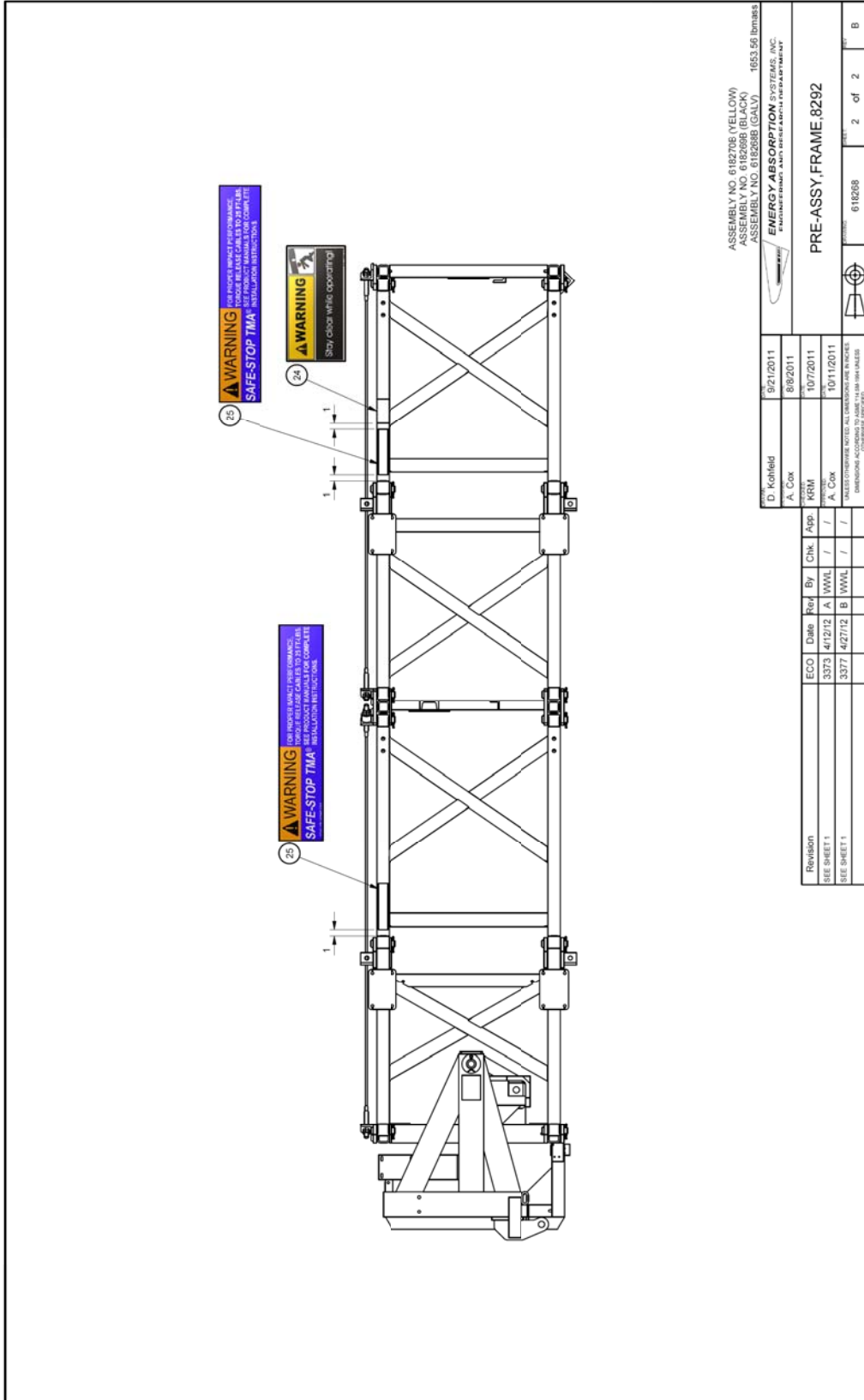

ASSEMBLY NO. 6182706 (YELLOW)
 ASSEMBLY NO. 6182698 (BLACK)
 ASSEMBLY NO. 6182688 (GALV) ... 1653.56 lbs/mats
ENERGY ABSORPTION SYSTEMS, INC.
 10000 Highway 100, Suite 100, Houston, TX 77060

DATE	9/21/2011	BY	D. Kohfeld
DATE	8/9/2011	BY	A. Cox
DATE	10/7/2011	BY	KRM
DATE	10/11/2011	BY	A. Cox

Revision	ECO	Date	Rev.	By	Chk.	App.
SEE SHEET 1	3373	4/12/12	A	WWL	/	/
SEE SHEET 1	3377	4/27/12	B	WWL	/	/

PRE-ASSY FRAME, 8292		618268	2 of 2	B
----------------------	--	--------	--------	---

DWG 618268 Sheet 2 of 2

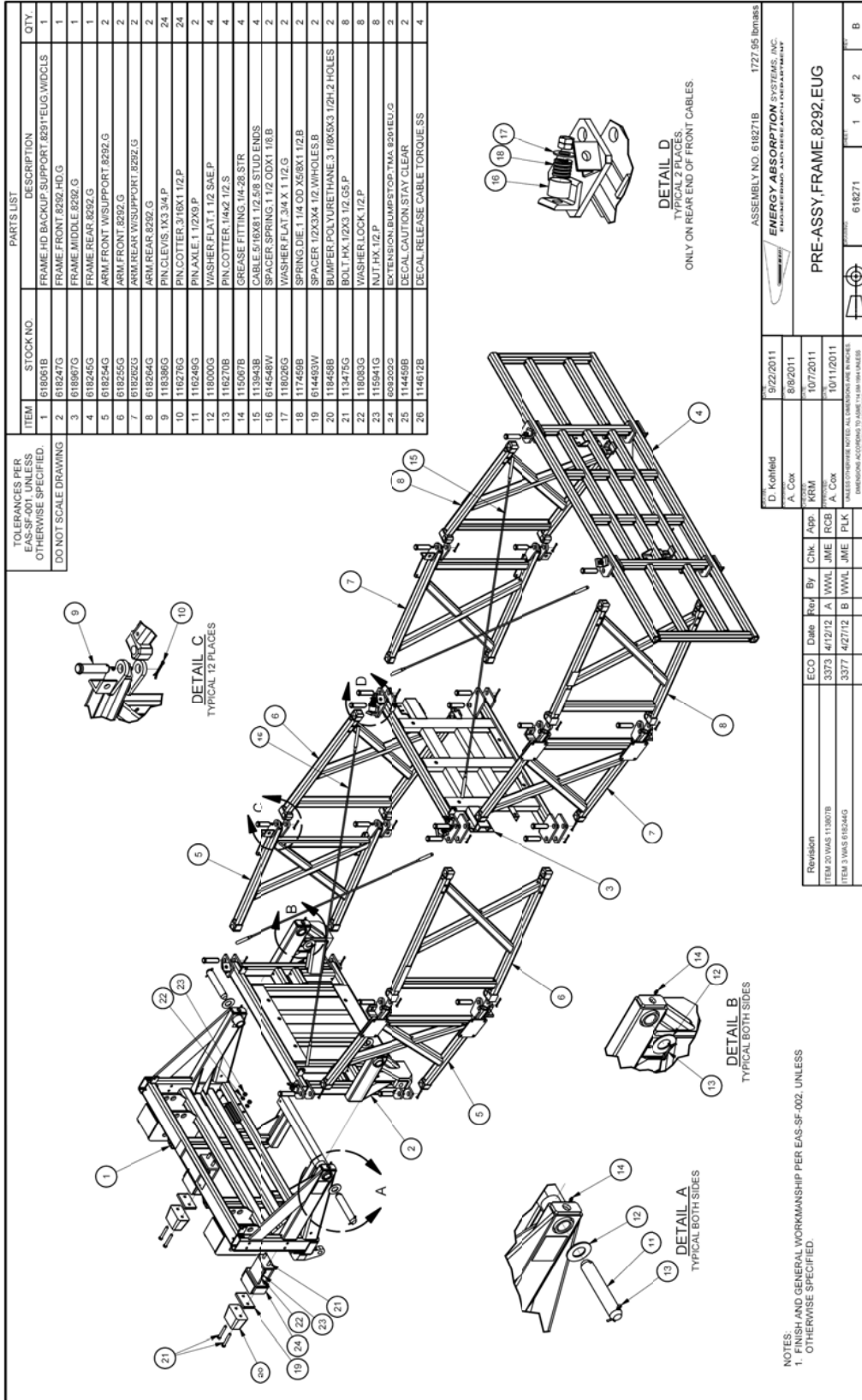

ITEM	STOCK NO.	DESCRIPTION	QTY
1	61806TB	FRAME HD BACKUP SUPPORT 8292/EUG.WDCLS	1
2	61824TG	FRAME FRONT 8292 HD.G	1
3	61896TG	FRAME MIDDLE 8292.G	1
4	618245G	FRAME REAR 8292.G	1
5	618254G	ARM FRONT WSUPPORT 8292.G	2
6	618255G	ARM FRONT 8292.G	2
7	618262G	ARM REAR WSUPPORT 8292.G	2
8	618264G	ARM REAR 8292.G	2
9	118396G	PIN,CLEVIS 1X3 3/4 P	34
10	116276G	PIN,COTTER,3/16X1 1/2 P	24
11	116276G	PIN,AXLE 1 1/2X3 P	2
12	118000G	WASHER FLAT, 1 1/2 SAE,P	4
13	116270B	PIN,COTTER, 1/4X2 1/2 S	4
14	115007B	GREASE FITTING,1/4-28,STR	4
15	113943B	CABLE,5/16X81 1/2,588 STUD ENDS	4
16	614548W	SPACER SPRING, 1 1/2 ODX1 1/8,B	2
17	118026G	WASHER FLAT,3/4 X 1 1/2,G	2
18	117456B	SPRING DIE,1 1/4 OD X5/8X1 1/2,B	2
19	614463W	SPACER 1/2X3/4 1/2,WHOLE S B	2
20	116458B	BUMPER POLYURETHANE,3 1/8X5X3 1/2H,2 HOLES	2
21	113475G	BOLT THX 1/2X3 1/2,G,P	8
22	118083G	WASHER LOCK,1/2,P	8
23	115941G	NUT,TK, 1/2,P	8
24	608202C	EXTENSION,BUMP STOP,TMA,8292/EUG	2
25	114456B	DECAL CAUTION,STAY CLEAR	2
26	114612B	DECAL RELEASE,CABLE TORQUE,SS	4

DATE	9/22/2011	ASSEMBLY NO. 618271B	172,06 lbmatts
BY	A. Cox	ENERGY ABSORPTION SYSTEMS, INC.	172,06 lbmatts
CHK	KRM	172,06 lbmatts	
APP	RCB	172,06 lbmatts	
DATE	10/17/2011	PRE-ASSY, FRAME, 8292, EUG	
BY	A. Cox		
CHK	PLK		
APP	PLK		
DATE	6/18/271		
BY			
CHK			
APP			

DATE	9/22/2011	ASSEMBLY NO. 618271B	172,06 lbmatts
BY	A. Cox	ENERGY ABSORPTION SYSTEMS, INC.	172,06 lbmatts
CHK	KRM	172,06 lbmatts	
APP	RCB	172,06 lbmatts	
DATE	10/17/2011	PRE-ASSY, FRAME, 8292, EUG	
BY	A. Cox		
CHK	PLK		
APP	PLK		
DATE	6/18/271		
BY			
CHK			
APP			

DATE	9/22/2011	ASSEMBLY NO. 618271B	172,06 lbmatts
BY	A. Cox	ENERGY ABSORPTION SYSTEMS, INC.	172,06 lbmatts
CHK	KRM	172,06 lbmatts	
APP	RCB	172,06 lbmatts	
DATE	10/17/2011	PRE-ASSY, FRAME, 8292, EUG	
BY	A. Cox		
CHK	PLK		
APP	PLK		
DATE	6/18/271		
BY			
CHK			
APP			

DWG 618271 Sheet 1 of 2

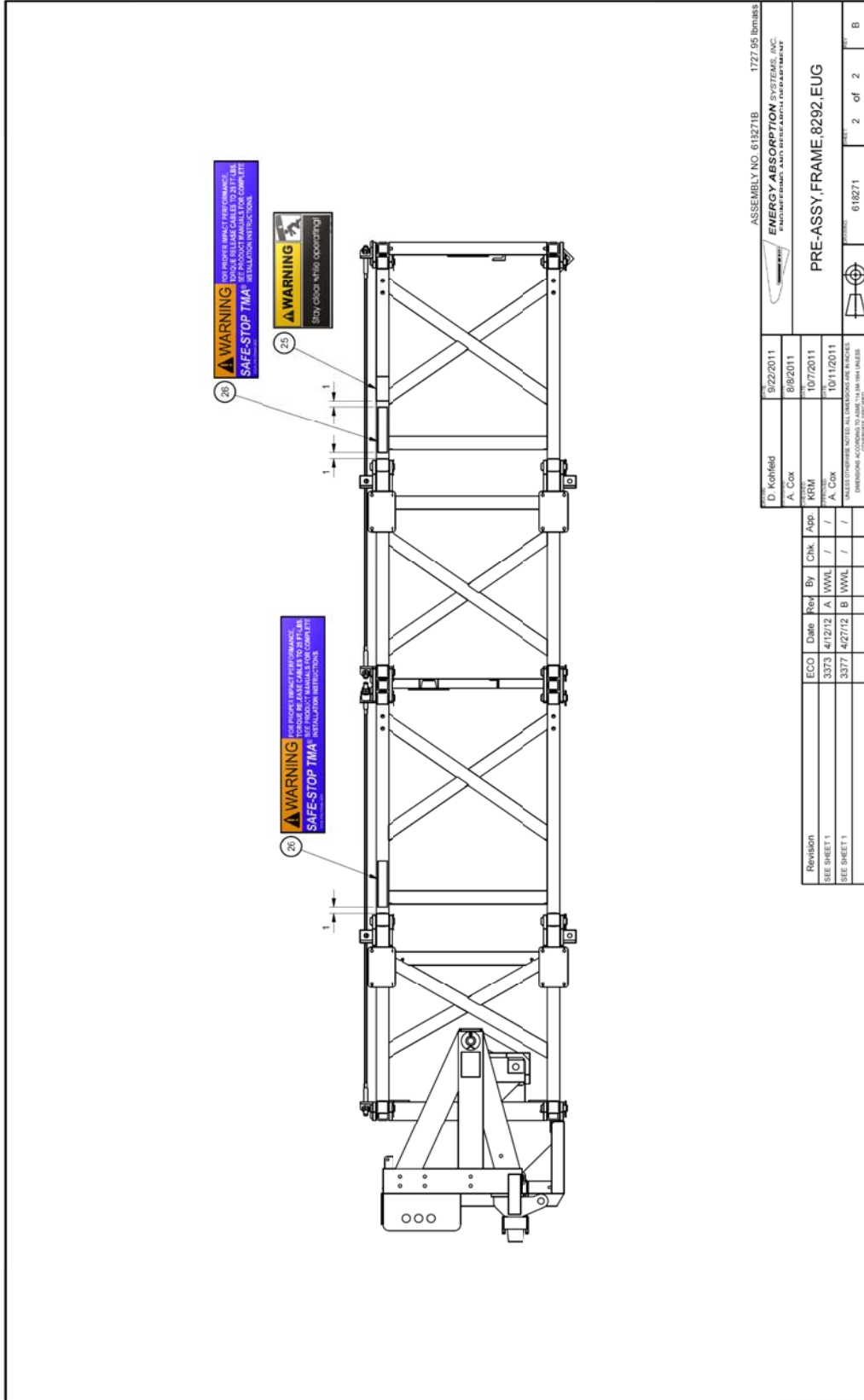

DWG 618271 Sheet 2 of 2

ASSEMBLY NO. 618271B		1727.95 lbs/mass												
ENERGY ABSORPTION SYSTEMS, INC. EQUIPMENT MODEL: 8292 PRE-ASSY FRAME														
DESIGNED BY	DATE	DESIGNED BY	DATE											
D. Kohfeld	9/22/2011	A. Cox	8/9/2011											
CHECKED BY	DATE	CHECKED BY	DATE											
A. Cox	10/7/2011	A. Cox	10/11/2011											
APPROVED BY	DATE	APPROVED BY	DATE											
A. Cox	10/11/2011	A. Cox	10/11/2011											
UNLESS OTHERWISE NOTED, ALL DIMENSIONS ON THIS DRAWING ARE IN INCHES DIMENSIONS ACCORDING TO ANSI Y14.5M-1994 UNLESS OTHERWISE SPECIFIED														
Revision	ECC	Date	Rev	By	Chk	App								
SEE SHEET 1	3373	4/12/12	A	WWL	/	/								
SEE SHEET 1	3377	4/27/12	B	WWL	/	/								
<table border="1"> <tr> <td>FIGURE NO.</td> <td>618271</td> <td>SHEET</td> <td>2</td> <td>OF</td> <td>2</td> <td>REV</td> <td>B</td> </tr> </table>							FIGURE NO.	618271	SHEET	2	OF	2	REV	B
FIGURE NO.	618271	SHEET	2	OF	2	REV	B							

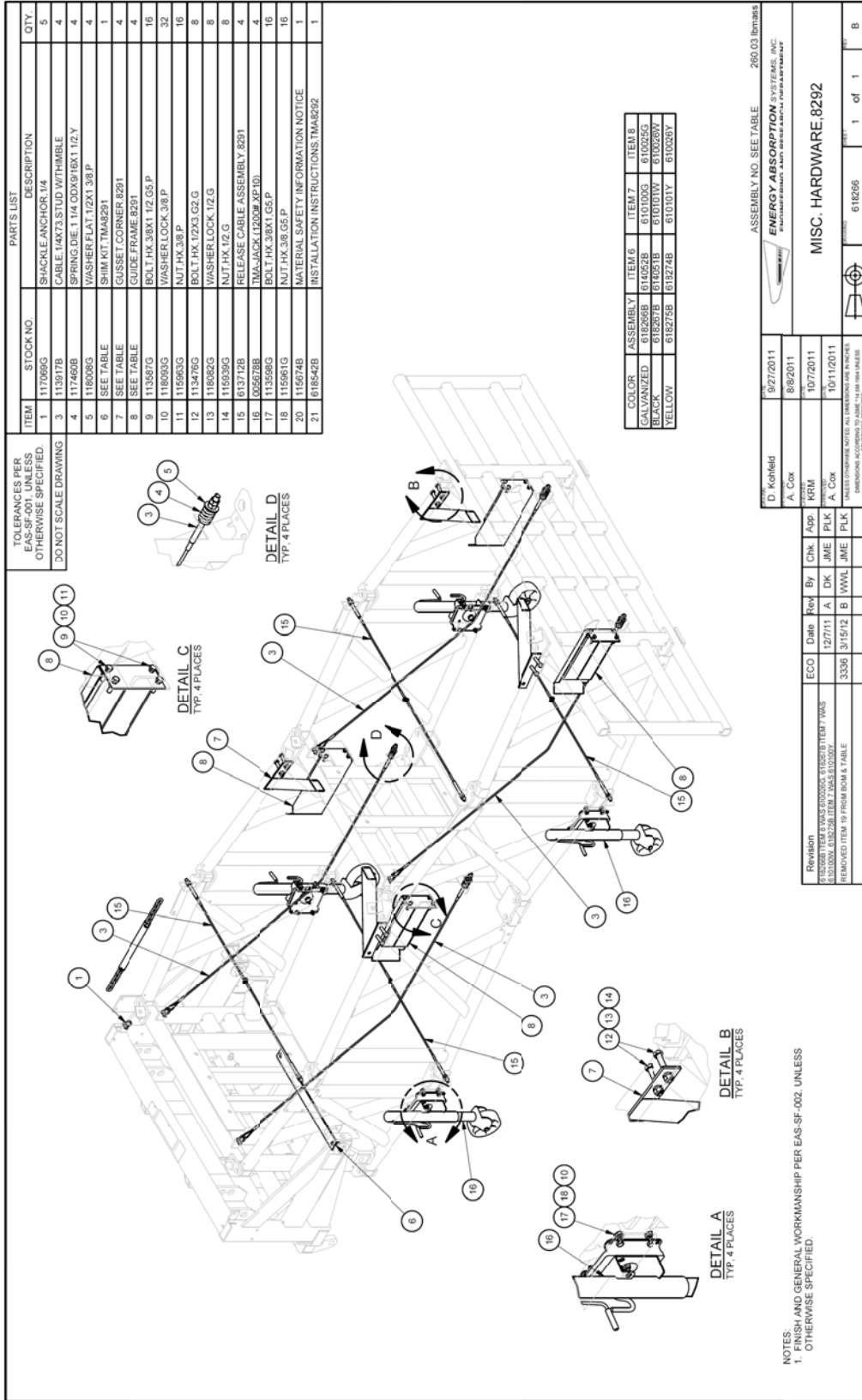

DWG 618266

PARTS LIST

ITEM	STOCK NO.	DESCRIPTION	QTY.
1	114413B	CYLINDER 3B 12S	2
2	118320B	PUMP SEAL MOTOR VERT. 12V HEAVY DUTY	1
3	118511G	BOLT HK 3/8X2.34 GS P	2
4	118037G	WASHER FLAT 3/8X1 P	2
5	118093G	WASHER LOCK 3/8 P	2
6	618277B	ELECTRICAL BOX HYDRAULIC PUMP 12V 8292	1
7	119250B	REDUCER BUSHING 1/2X1/4 NPT P	2
8	114825G	ELBOW MALE 1/2X3/8 P	2
9	116250G	PN. CLEVIS 1X3 1/2 P	4
10	116276G	PN. COTTER 3/16X1 1/2 P	4
11	117798B	TEE BRANCH 1/4 FEMALE P	2
12	114838B	ELBOW STREET 3/8 MALE X 1/4 FEM P	4
13	114784G	ELBOW 4#4 ORB X #4 NPT P	2
14	115174B	HOSE ASSY HYDRAULIC 90°	4
15	115178B	HOSE ASSY HYDRAULIC 44°	2
16	115946G	NUT HK 1/4 G	4
17	118086G	WASHER LOCK 1/4 P	4
18	118096G	WASHER FLAT 1/4X1 P	4
19	113516G	BOLT HK 1/4X3/4 GS G	4
20	117763B	TEE NYLON 1/4 BLACK	10

OPTIONAL ITEMS

ITEM	STOCK NO.	DESCRIPTION	QTY.
21	518504B	CONTROL BOX ASSY CAB 8292	1
22	518556B	CABLE BATTERY 20A 25FT QUICK END	1

INSTALL AND ADJUST SO THAT SWITCH IS DEPRESSED WHEN SYSTEM IS IN THE RAISED POSITION.

INSTALL AND ADJUST SO THAT SWITCH IS DEPRESSED WHEN SYSTEM IS IN THE LOWERED POSITION.

TOLERANCES PER EAS-SF-001, UNLESS OTHERWISE SPECIFIED. DO NOT SCALE DRAWING.

NOTES:
1. FITS AND GENERAL WORKMANSHIP PER EAS-SF-002, UNLESS OTHERWISE SPECIFIED.
2. SECURE LOOSE CABLES AND HOSES WITH ITEM 23.

D. Kothfield		11/30/2011		ASSEMBLY NO. 618556B		95.02 Items	
R. Brougher		12/27/2011		ENERGY ABSORPTION SYSTEMS, INC. ENGINEERING AND RESEARCH DEPARTMENT			
ECO	Date	By	Chk	App			
3336	3/15/12	A. WWL	JME	PLK	HYDRAULIC/ELECTRICAL ASSY, 8292		
3371	5/24/12	B. DDW	JME	AJC	SALES OPERATIONS (NOT ALL DIMENSIONS ARE IN INCHES) DIMENSIONS ARE GIVEN IN INCHES UNLESS OTHERWISE SPECIFIED.		

1 of 3

618556

DWG 618586 Sheet 1 of 3

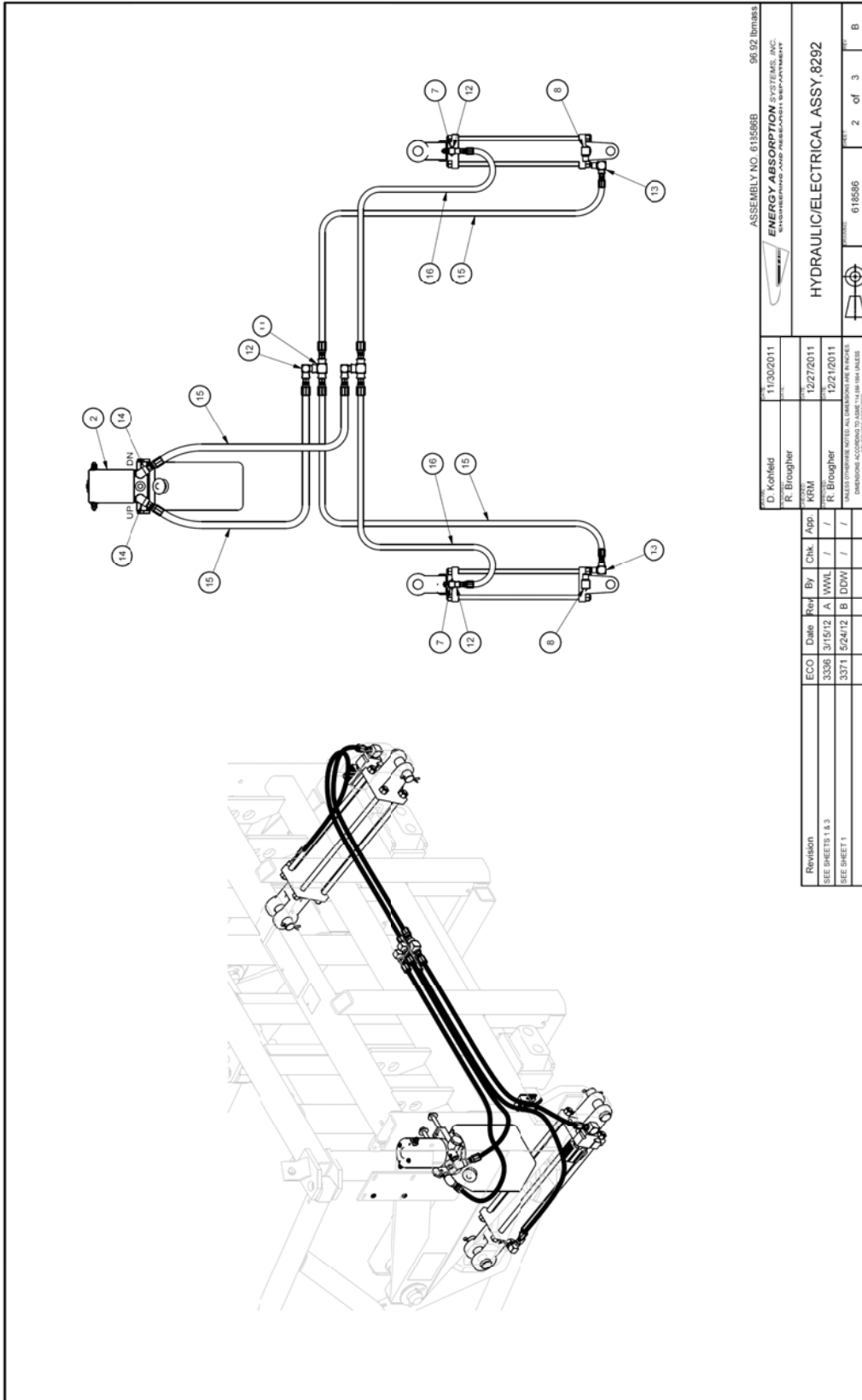

DWG 618586 Sheet 2 of 3

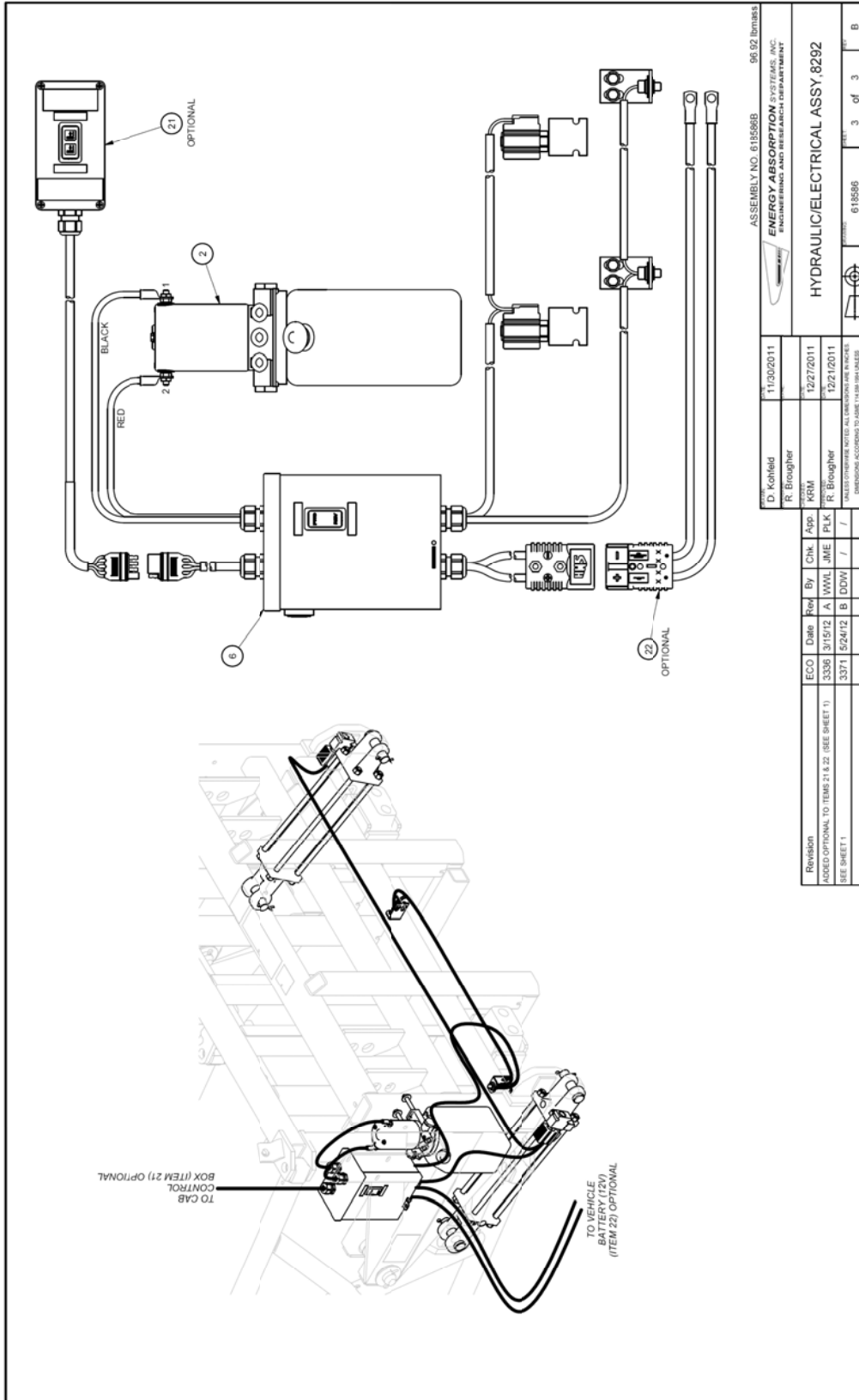

ASSEMBLY NO. 618586 96.02 Items

ENERGY ABSORPTION SYSTEMS, INC.
ENGINEERING AND RESEARCH DEPARTMENT

HYDRAULIC/ELECTRICAL ASSY, 8292

Revision	ECO	Date	For	By	CHK	App.	DATE
ADDED OPTIONAL TO ITEMS 21 & 22 (SEE SHEET 1).	3336	3/15/12	A	WWL	JME	PLK	12/27/2011
SEE SHEET 1	3371	5/24/12	B	DDW	/	/	12/21/2011

UNLESS OTHERWISE NOTED, ALL DIMENSIONS ARE IN INCHES.
DIMENSIONS ACCORDING TO ASME Y14.5M-1994 (LATEST EDITION)

DATE	11/02/2011
DESIGNER	R. Brougher
DATE	12/27/2011
DESIGNER	R. Brougher

618586 3 of 3 B

DWG 618586 Sheet 3 of 3

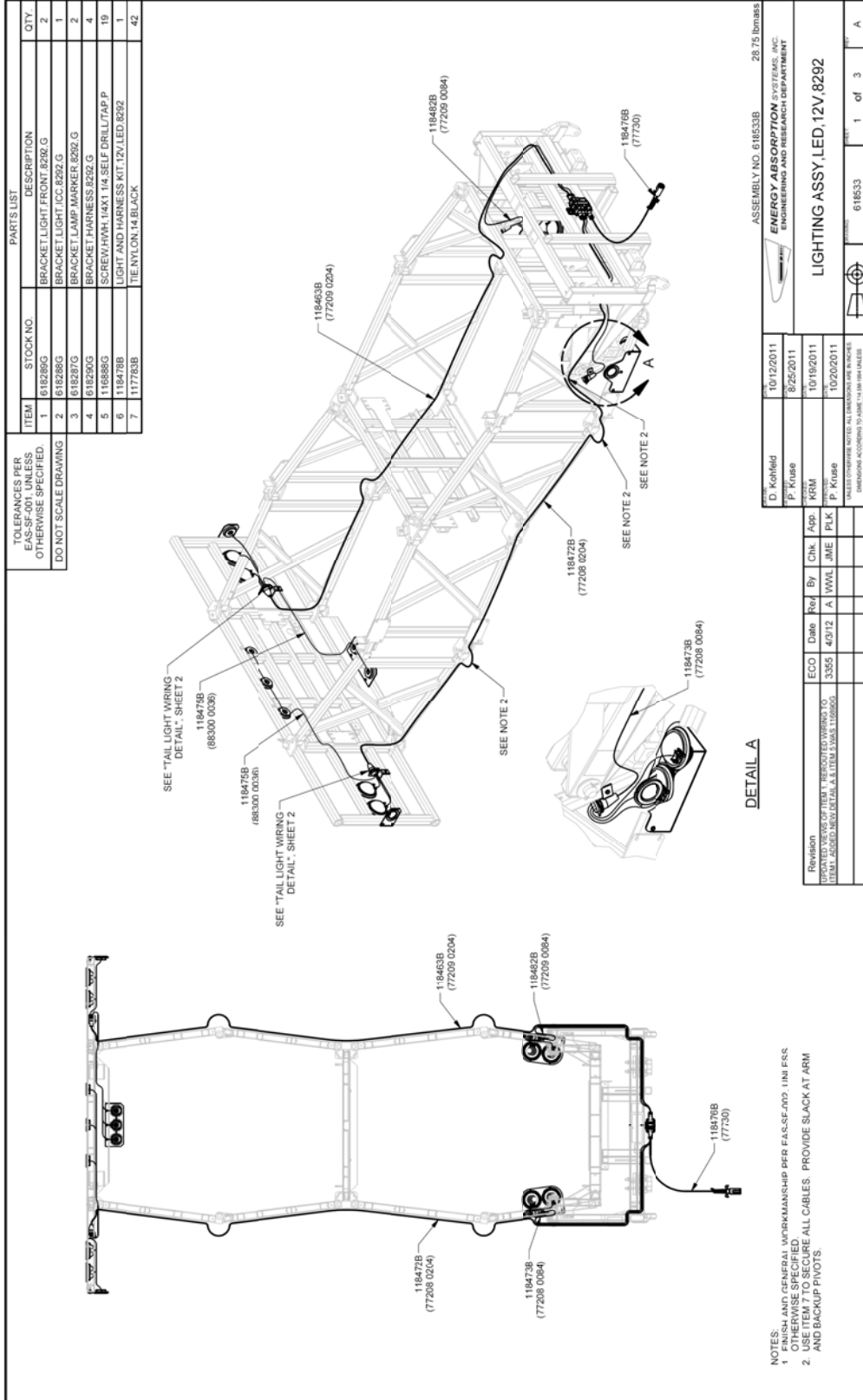

DWG 618533 Sheet 1 of 3

Lighting Assembly, LED, 12V, 8292

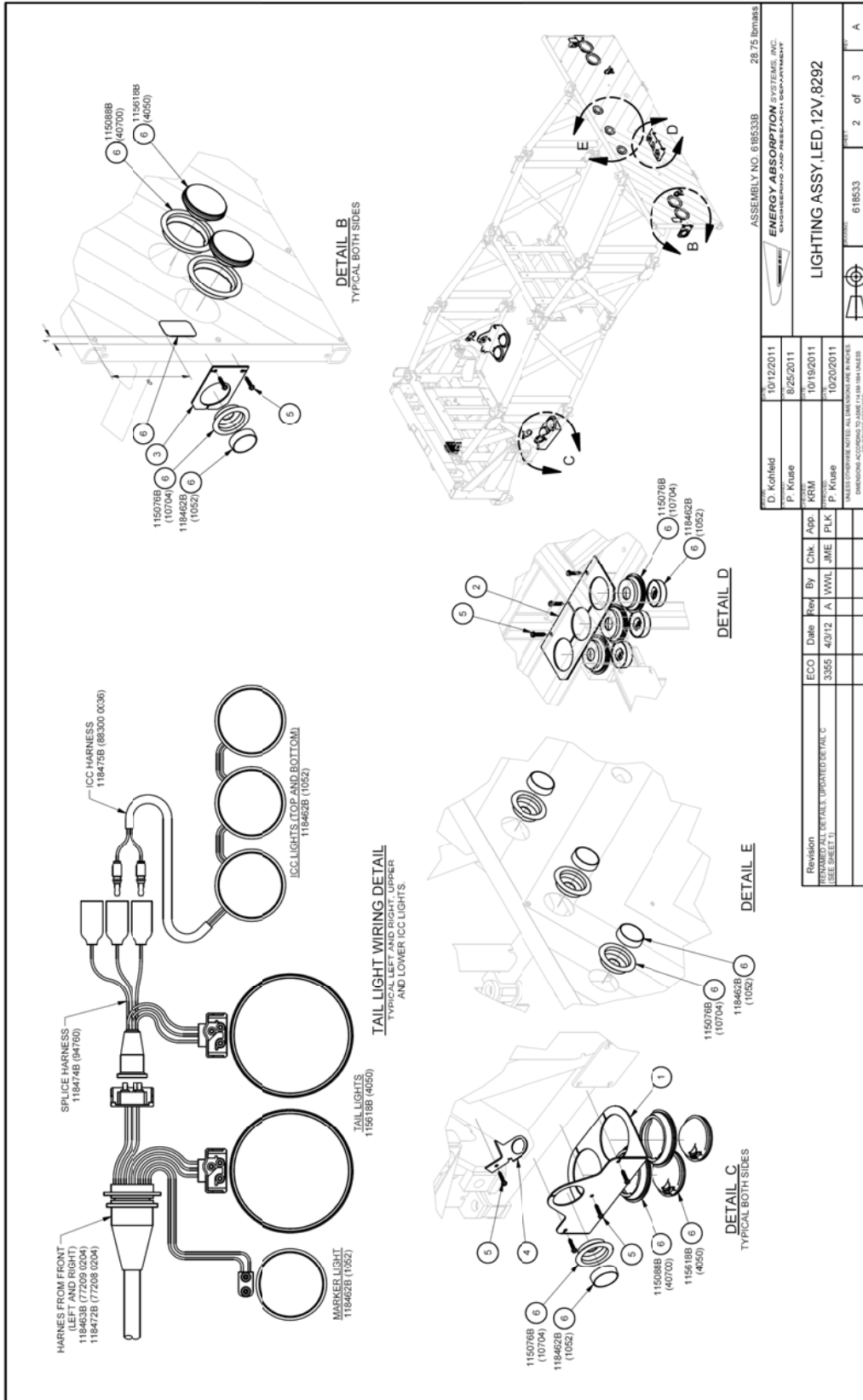

DWG 618533 Sheet 2 of 3

DESIGNED BY	D. Kohfeld	DATE	10/12/2011
CHECKED BY	P. Krause	DATE	8/25/2011
APPROVED BY	KRM	DATE	10/19/2011
PLANNED BY	PLK	DATE	10/20/2011
ALL DIMENSIONS UNLESS OTHERWISE SPECIFIED ARE IN MILLIMETERS DIMENSIONS ACCORDING TO JIS B 3101-1:2003			
PART NUMBER: 618533 QUANTITY: 2 of 3 REV: A			
ASSEMBLY NO. 618533B 28.75 lbs/mass ENERGY ABSORPTION SYSTEMS, INC. ENGINEERING AND RESEARCH DEPARTMENT LIGHTING ASSY, LED, 12V, 8292			

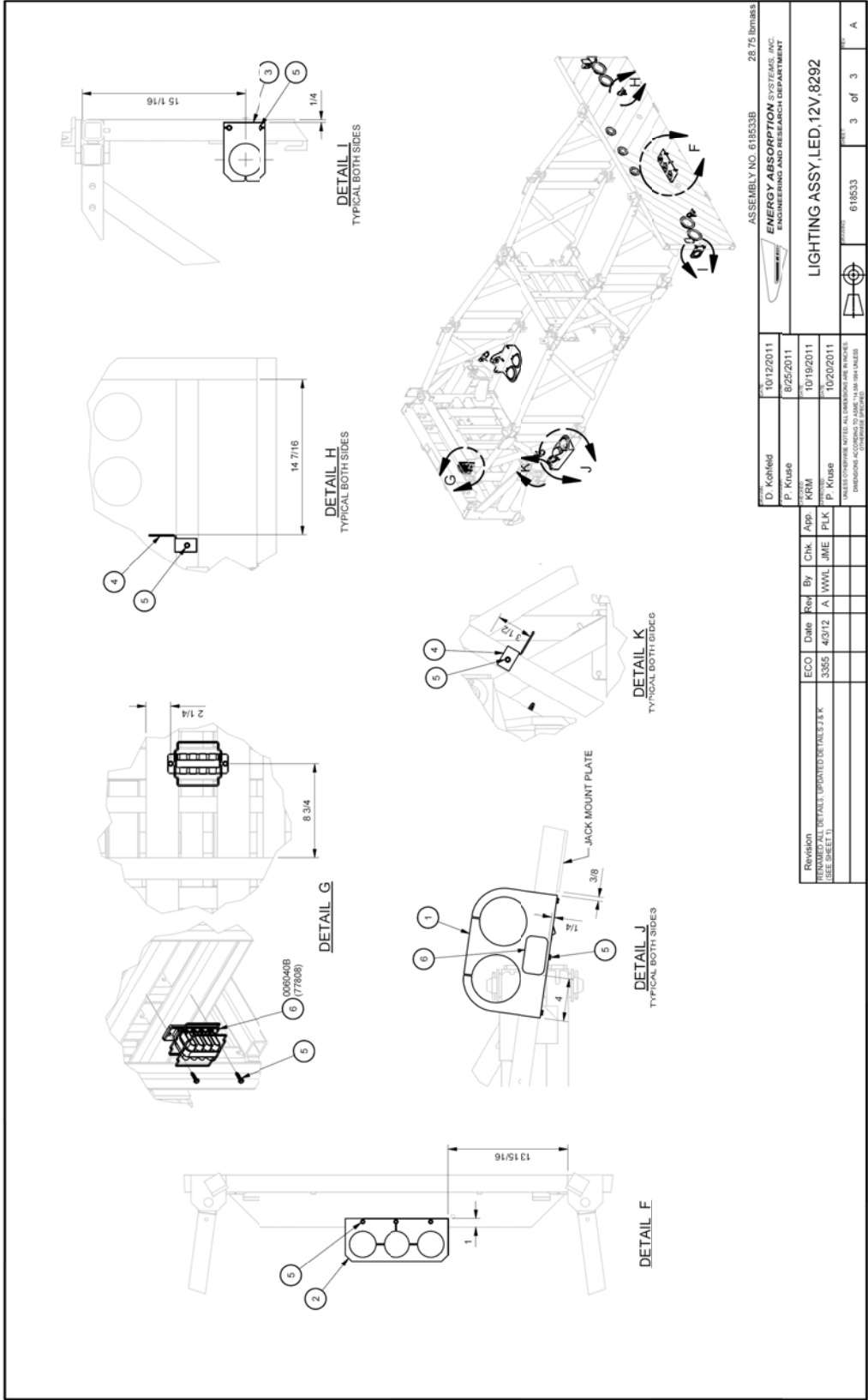

DWG 618533 Sheet 3 of 3

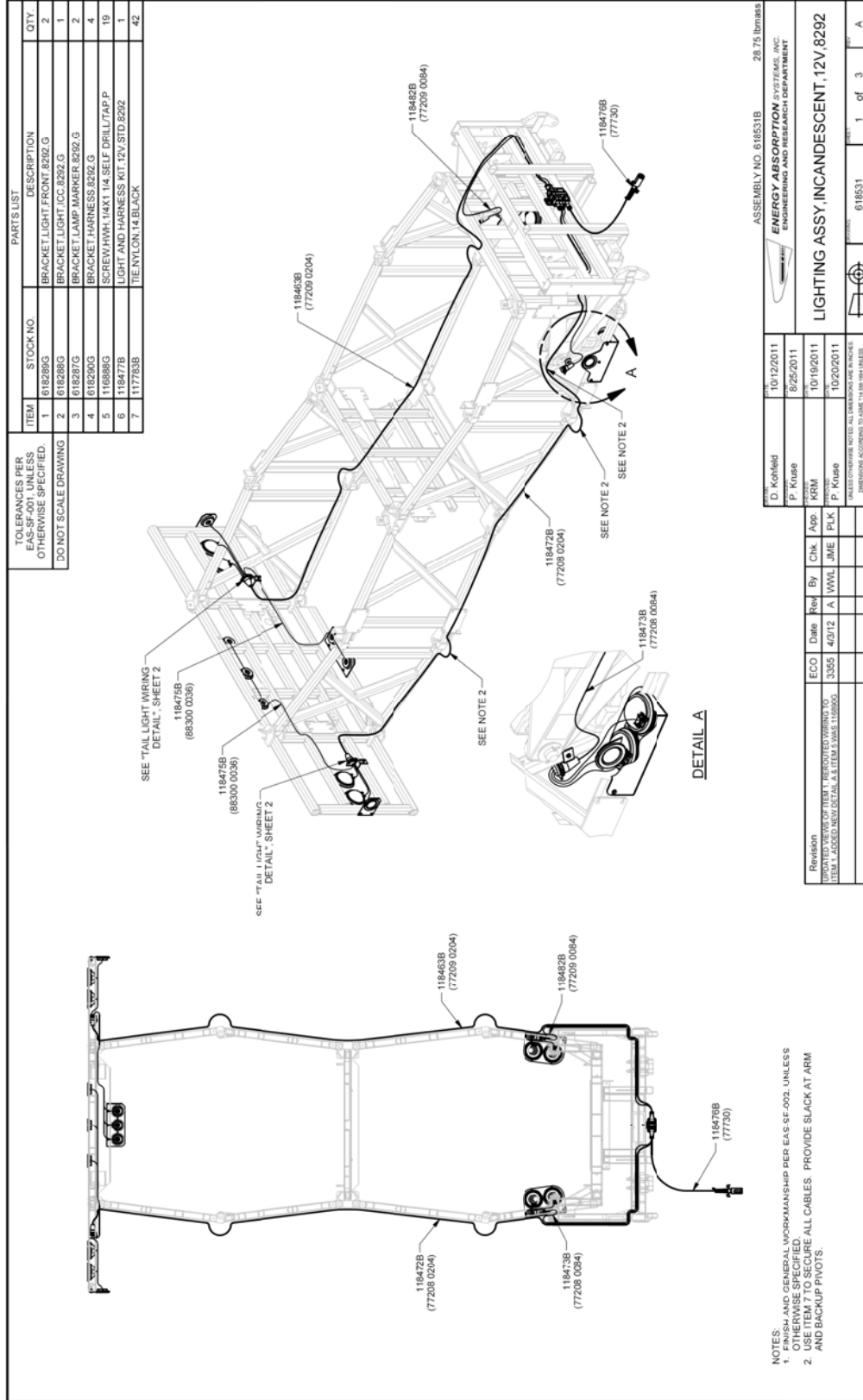

Lighting Assembly, Incandescent, 12V, 8292

DWG 618531 Sheet 1 of 3

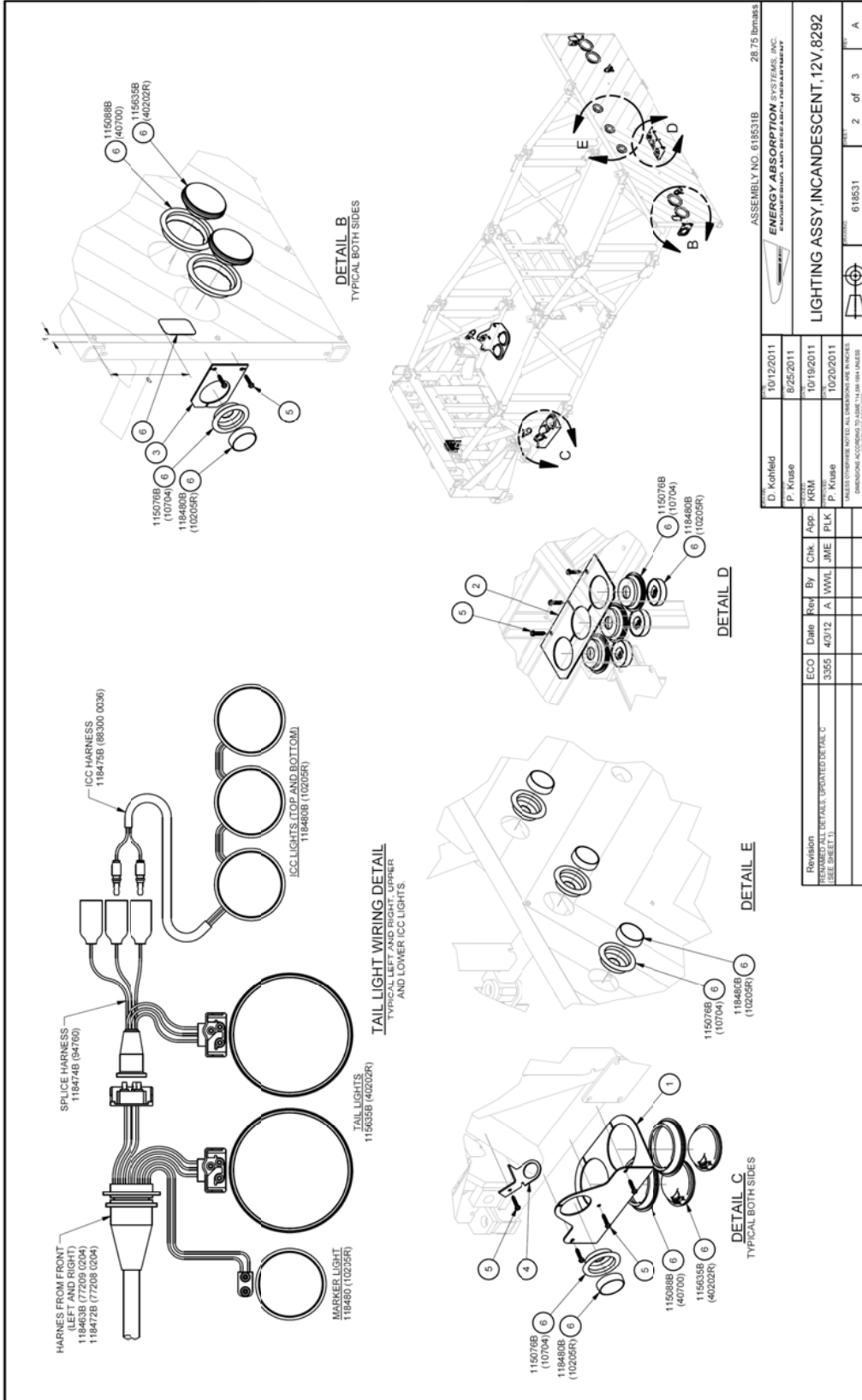

DESIGNED BY	D. Kohfeld	DATE	10/12/2011
CHECKED BY	P. Kruse	DATE	8/25/2011
APPROVED BY	KRM	DATE	10/19/2011
PLK	P. Kruse	DATE	10/20/2011

REVISION	DATE	BY	CHK	APP
1	3/3/12	A	WML	JME

ASSEMBLY NO.	618531B	28.75 lbs/mass
ENERGY ABSORPTION SYSTEMS, INC. P.O. BOX 10000, WYOMING, WY 83001-0000		
LIGHTING ASSY, INCANDESCENT, 12V, 8292		
FIG. NO.	618531	SHEET
	2	of 3
DIMENSIONS ACCORDING TO ASME Y14.5M-1994 UNLESS OTHERWISE SPECIFIED		

DWG 618531 Sheet 2 of 3

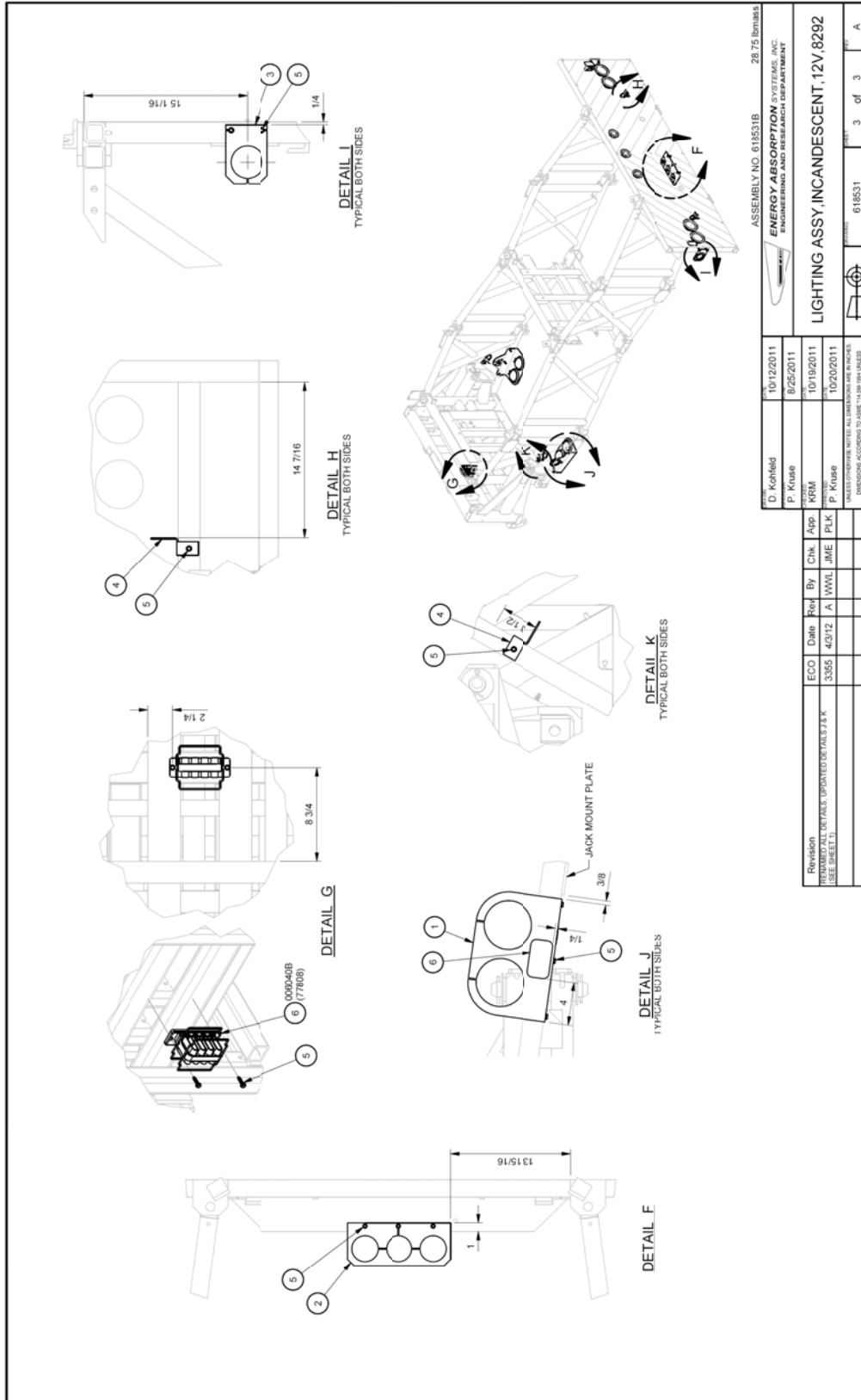

ASSEMBLY NO. 618531B 28.75 INCHES
ENERGY ABSORPTION SYSTEMS, INC.
 ENGINEERING AND RESEARCH DEPARTMENT

DESIGNED BY	D. Kottlieb	DATE	10/12/2011
CHECKED BY	P. Kruse	DATE	8/25/2011
APPROVED BY	KRM	DATE	10/19/2011
DATE	10/20/2011	DATE	10/20/2011

REVISED	REASON FOR CHANGE	DATE	BY	CHK	APP
3365	4/3/12 A. WWIL	4/3/12	A. WWIL	JME	PLK

UNLESS OTHERWISE NOTED, ALL DIMENSIONS ARE IN INCHES
 DIMENSIONS ACCORDING TO ANSI Y14.1M-1994 UNLESS
 OTHERWISE SPECIFIED

618531 3 of 3

DWG 618531 Sheet 3 of 3

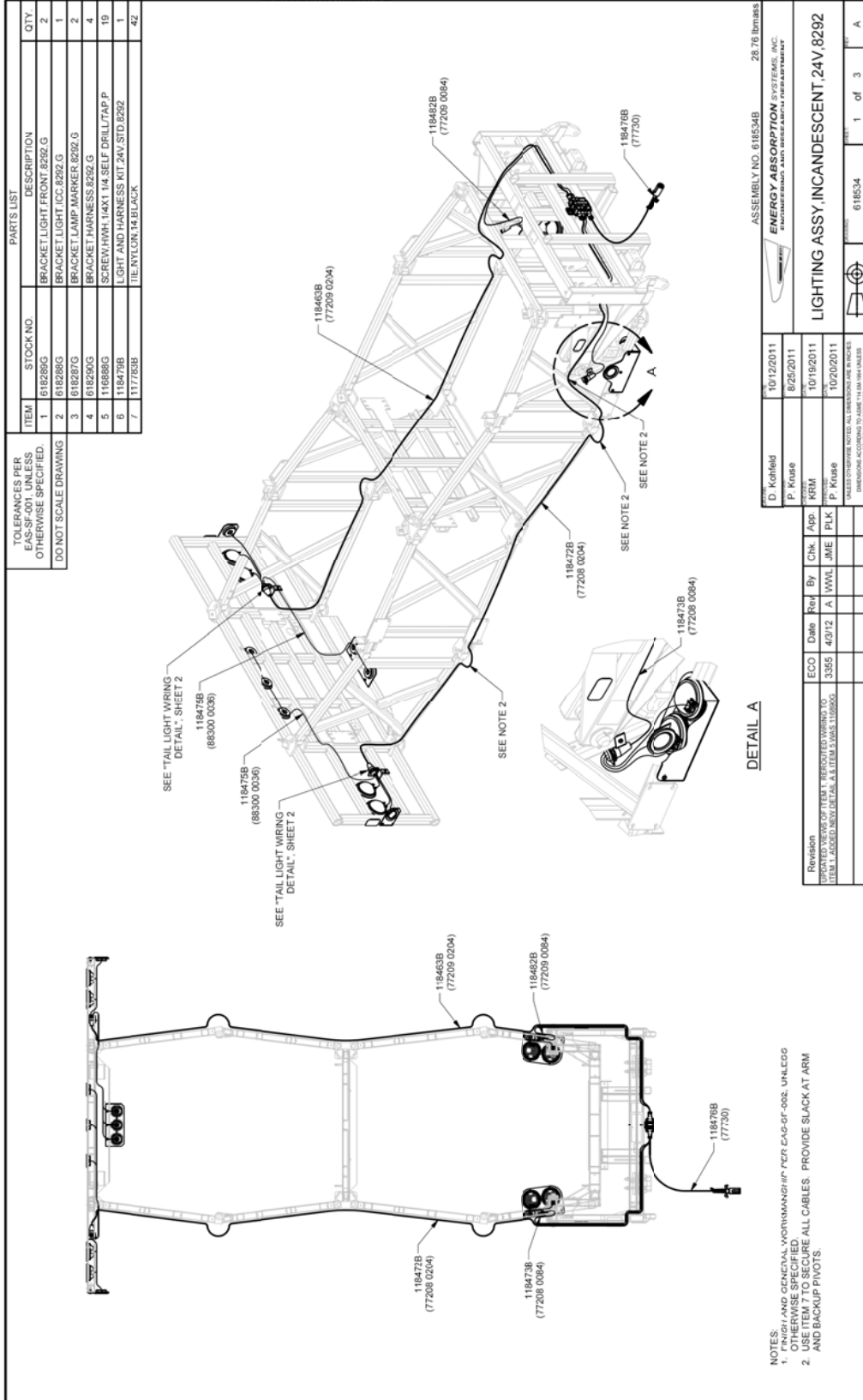

DWG 618534 Sheet 1 of 3

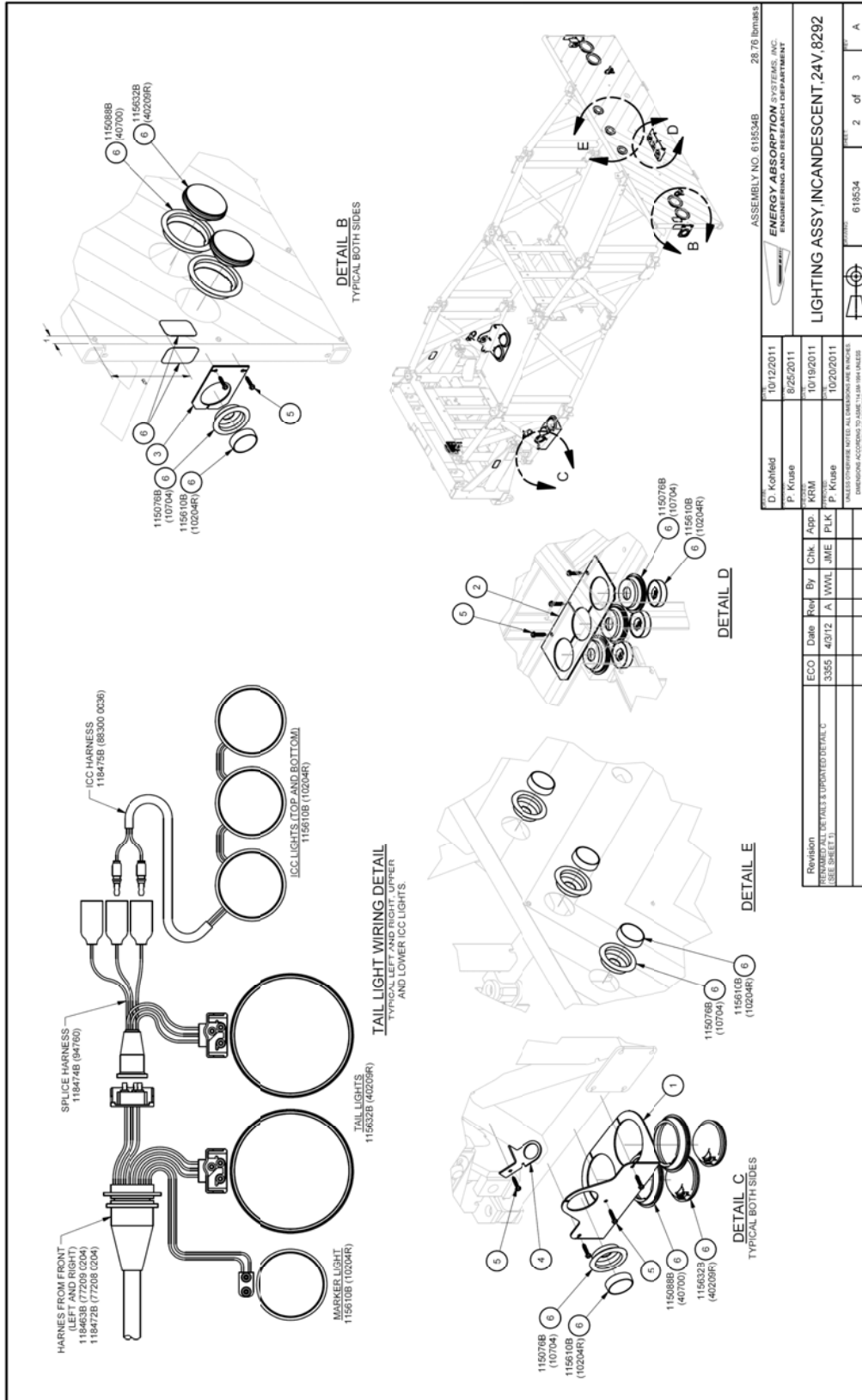

DWG 618534 Sheet 2 of 3

ASSEMBLY NO. 618534		28 76 IRRMMS			
ENERGY ABSORPTION SYSTEMS, INC. ENGINEERING AND RESEARCH DEPARTMENT					
DESIGNED BY	D. Kotheid	DATE	10/12/2011		
CHECKED BY	P. Krue	DATE	8/25/2011		
APPROVED BY	P. Krue	DATE	10/19/2011		
ISSUED BY	P. Krue	DATE	10/20/2011		
UNLESS OTHERWISE NOTED, ALL DIMENSIONS ARE IN INCHES DIMENSIONS ACCORDING TO ASME Y14.5M-1994 (LATEST EDITION) ARE REQUIRED					
REVISION	NO.	DATE	BY	CHK.	APP.
1	3355	4/3/12	A	WWL	JME
2					
3					
4					
5					
6					
7					
8					
9					
10					
11					
12					
13					
14					
15					
16					
17					
18					
19					
20					
21					
22					
23					
24					
25					
26					
27					
28					
29					
30					
31					
32					
33					
34					
35					
36					
37					
38					
39					
40					
41					
42					
43					
44					
45					
46					
47					
48					
49					
50					
51					
52					
53					
54					
55					
56					
57					
58					
59					
60					
61					
62					
63					
64					
65					
66					
67					
68					
69					
70					
71					
72					
73					
74					
75					
76					
77					
78					
79					
80					
81					
82					
83					
84					
85					
86					
87					
88					
89					
90					
91					
92					
93					
94					
95					
96					
97					
98					
99					
100					

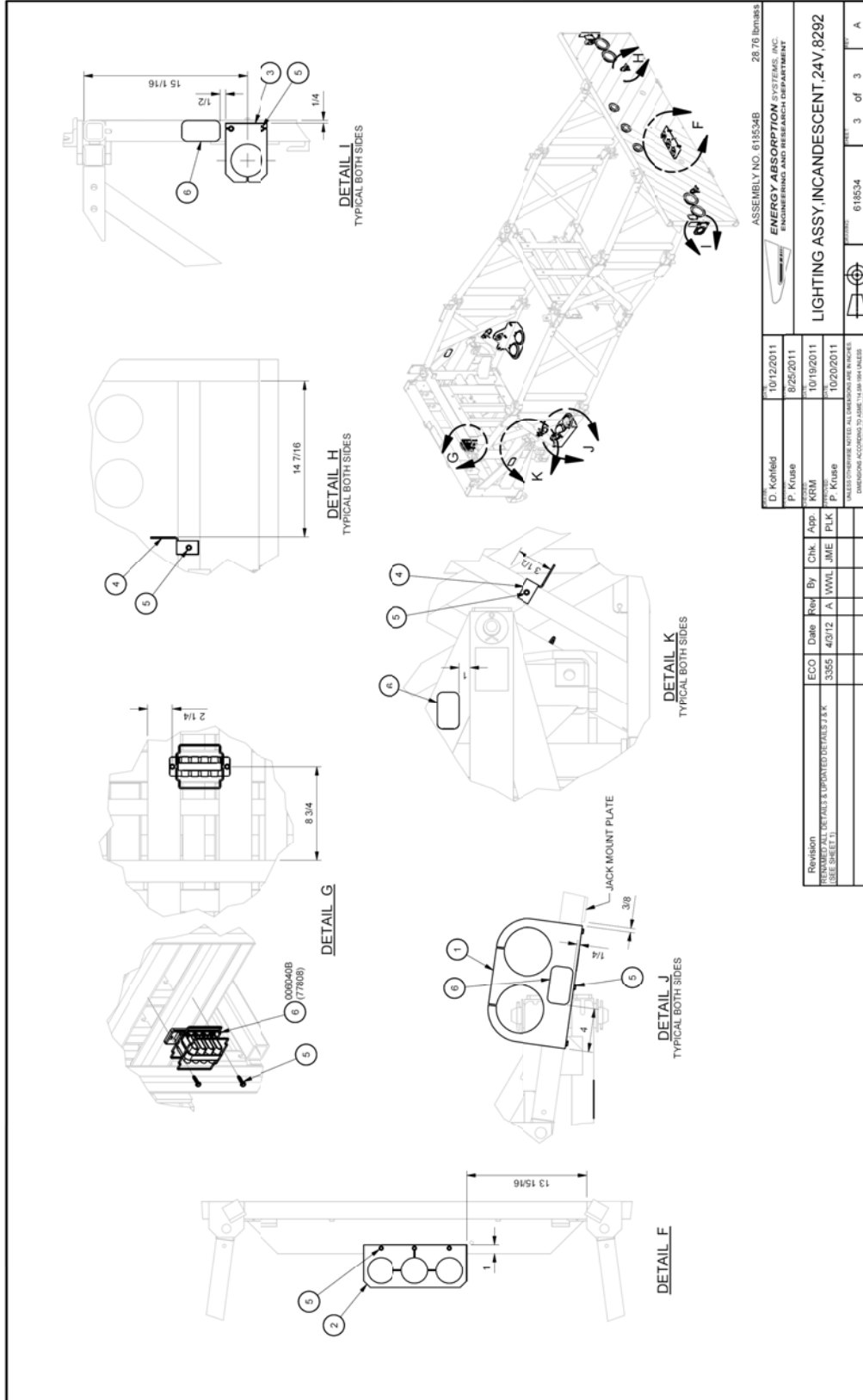

DWG 618534 Sheet 3 of 3

TOLERANCES PER EAS-SF-001, UNLESS OTHERWISE SPECIFIED.		PARTS LIST	
ITEM	STOCK NO.	DESCRIPTION	QTY.
1	SEE TABLE	STRIPING ASSY 8292	1
2	116890G	SCREW HHW, 1/4X1 SELF DRILL/TAP P	19

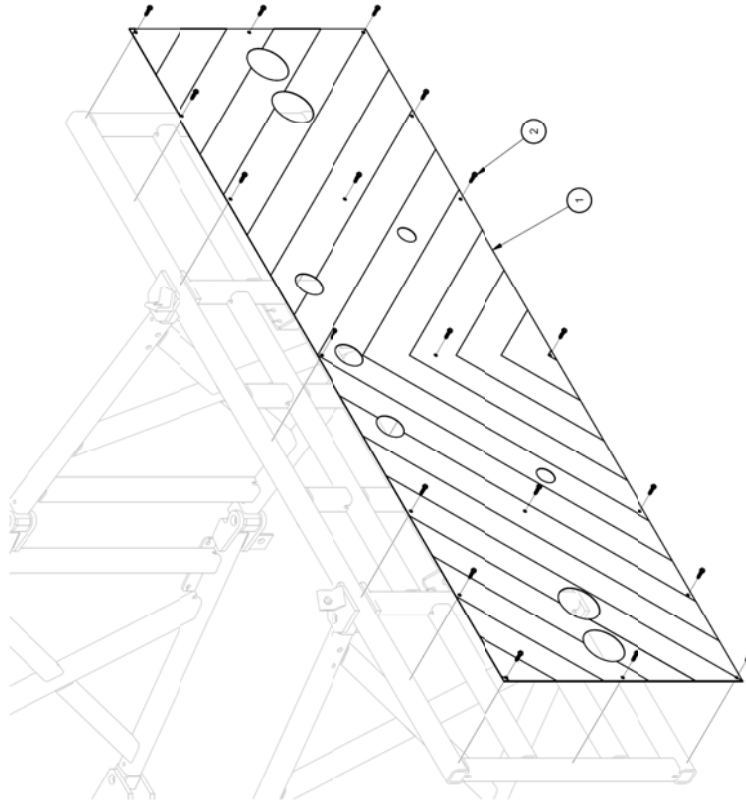

ASSEMBLY NO.	ITEM I. NO.	DESCRIPTION
	618485B	4" BLACK
	618486B	4" ORANGE/BLACK VA
	618487B	4" RED/WHITE TX
	618488B	5" ORANGE/WHITE FL
	618489B	4" YEL REFL/BLK
	618512B	4" BLUE, NY
	618513B	4" ORANGE, MD
	618517B	5" BLACK REFL PA
	618518B	5" BLACK REFL MO
	618519B	5" BLACK/ORANGE PA TPK
	618520B	5" ORANGE/BLACK VAZ
	618521B	12" RED/WHITE MO
	620087B	4" RED REFL TRK

PART NO. SEE TABLE		10:50 lbs/mass	
ENERGY ABSORPTION SYSTEMS		10/5/2011	
REAR PLATE ASSY, W/STRIPING, 8292		7/25/2011	
D. Kohtelid		10/19/2011	
P. Kruse		10/20/2011	
P. Kruse		10/20/2011	
UNLESS OTHERWISE NOTED, ALL DIMENSIONS ARE IN INCHES		UNLESS OTHERWISE SPECIFIED	
DIMENSIONS ACCORDING TO ASME Y14.5M-1994		618505	
1 of 1		1 of 1	

Rear Plate Assembly, w/Striping, 8292

NOTES:
1. FINISH AND GENERAL WORKMANSHIP PER EAS-SF-002, UNLESS OTHERWISE SPECIFIED.

DWG 618505

Notes:



2525 Stemmons Freeway

Dallas, Texas 75207

888-323-6374 (USA only)

312-467-6750 (Outside USA)

www.energyabsorption.com

www.highwayguardrail.com