



# QuadGuard<sup>®</sup> Elite M10 [24"]

CRASH CUSHIONS

PRODUCT MANUAL



**PN 620076**

AUGUST 2022

# QuadGuard® Elite M10 [24"]

The QuadGuard® Elite M10 has been tested pursuant to AASHTO MASH specifications. This system has been deemed eligible for Federal-aid reimbursement on the NHS by the FHWA.

## Product Description Assembly Manual



15601 Dallas Parkway  
Suite 525  
Addison, Texas 75001



**Warning:** The local highway authority, distributors, owners, contractors, lessors, and lessees are **RESPONSIBLE** for the assembly, maintenance, and repair of the QuadGuard® Elite M10. Failure to fulfill these **RESPONSIBILITIES** with respect to the assembly, maintenance, and repair of the QuadGuard® Elite M10 could result in serious injury or death.



**Important:** These instructions are for standard assembly specified by the appropriate highway authority. In the event the specified system assembly, maintenance, or repair would require a deviation from standard assembly parameters, contact a Valtir representative. This system has been deemed eligible by the FHWA for use on the NHS under strict criteria utilized by that agency.

**This manual must be available to the worker overseeing and/or assembling the product at all times. For additional copies, contact Valtir directly at (888) 323-6374 or visit [Valtir.com](http://Valtir.com).**

The instructions contained in this manual supersede all previous information and manuals. The information, illustrations, and specifications in this manual are based on the latest QuadGuard® Elite M10 system information available to Valtir at the time of printing. We reserve the right to make changes at any time. Please contact Valtir to confirm that you are referring to the most current instructions.

# **Table of Contents**

Customer Service Contacts .....	3
Abbreviations .....	3
Important Introductory Notes .....	3
Safety Symbols .....	4
Safety Rules for Assembly .....	4
Limitations and Warnings.....	5
System Overview .....	6
Inspect Shipping.....	6
System Assemblies.....	7
Select Transition .....	15
Recommend Tools.....	16
Site Preparation/Foundation .....	18
Foundation/Anchoring.....	19
Valtir Approved Adhesive Anchoring System .....	20
Vertical Anchors .....	20
Anchor Assembly Cautions for Steel Rebar .....	21
Horizontal Anchors.....	22
Measuring the Width .....	25
Assembly Procedures .....	26
Tension Strut Backup.....	26
Pre-Assembled System Installation Instructions .....	40
QuadGuard® Elite M10 Final Inspection Checklist.....	41
Maintenance and Repair.....	42
Visual Drive-By Inspection .....	42
Walk-Up Inspection.....	42
Post-Impact Instructions.....	44
Parts Ordering Procedure .....	47
Maintenance Flow Chart .....	47
Drawings .....	48
QuadGuard® Elite M10 QGEMTSCVR-U .....	48
TS Concrete Pad 618686.....	49
TS Concrete Pad 8" w/Rebar 618686 .....	50
TS Concrete Pad 8" wo/Rebar 618686 .....	51
4" Offset Safety Shape Transition QGEMTSCVR-T4LR .....	52
6" Offset Single Slope Transition QGEMTSCVR-T6LR.....	53
Thrie-Beam Transition QGEMTSCVR-TTLR.....	54
End Shoe Transition QGEMTSCVR-ESLR .....	55
Extended End Shoe Transition QGEMTSCVR-SPE .....	56
31" W-Beam Transition QGEMTSCVR-TWLR .....	57

## Customer Service Contacts

Valtir is committed to the highest level of customer service. Feedback regarding the QuadGuard® Elite M10 system, its assembly procedures, supporting documentation, and performance is always welcome. Additional information can be obtained from the contact information below:

### **Valtir**

Telephone	(888) 323-6374 (USA) +1 312 467 6750 (International)
Contact Link	<a href="http://Valtir.com/Contact">Valtir.com/Contact</a>

## Abbreviations

<b>AASHTO</b>	<b>American Association of State Highway and Transportation Officials</b>
<b>FHWA</b>	<b>Federal Highway Administration</b>
<b>MASH</b>	<b>Manual for Assessing Safety Hardware</b>
<b>MUTCD</b>	<b>Manual on Uniform Traffic Control Devices</b>
<b>NHS</b>	<b>National Highway System</b>

## Important Introductory Notes

The performance of the QuadGuard® Elite M10 as designed, and approved for reimbursement by the FHWA pursuant to its MASH standard, is dependent upon the proper assembly, deployment and future maintenance of the system. These instructions should be read in their entirety and understood before assembling the QuadGuard® Elite M10. These instructions are to be used in conjunction with the assembly of QuadGuard® Elite M10 system and are for standard assemblies only as specified by the applicable highway authority. If you need additional information, or have questions about the QuadGuard® Elite M10, please contact the highway authority that has planned and specified this assembly and, if needed, contact Valtir Customer Service. This product must be assembled in the location specified by the appropriate highway authority. If there are deviations, alterations, or departures from the assembly protocol specified in this manual, the device may not perform as tested.



**Important: DO NOT** use any component part that has not been specifically approved for this system during the assembly or repair of this system.

This product has been specified for use by the appropriate highway authority and has been provided to that user who has unique knowledge of how this system is to be assembled. No person should be permitted to assist in the assembly, maintenance, or repair of this system that does not possess the unique knowledge described herein. These instructions are intended for an individual qualified to both read and accurately interpret them as written. These instructions are intended only for an individual experienced and skilled in the assembly of highway products that are specified and selected by the highway authority.

A Manufacturer's Drawing Package will be supplied by Valtir upon request. Each system will be supplied with a specific drawing package unique to that system. Such drawings take precedence over information in this manual and shall be studied thoroughly by a qualified individual who is skilled in interpreting them before the start of any product assembly.

## Safety Symbols

This section describes the safety symbols that appear in this QuadGuard® Elite M10 manual. Read the manual for complete safety and assembly information.

### Symbol

### Meaning



**Safety Alert Symbol:** Indicates Important, Caution, Warning, or Danger. Failure to read and follow the Important, Caution, Warning, or Danger indicators could result in serious injury or death to workers and/or bystanders.



**Warning:** Read safety instructions thoroughly and follow the assembly directions and suggested safe practices before assembling, maintaining, or repairing the QuadGuard® Elite M10. It is the responsibility of the installer to follow the instructions contained in this manual. Failure to comply with these warnings could result in increased risk of serious injury or death in the event of a vehicle impact.



**Important:** Please keep up-to-date instructions for later use and reference by anyone involved in the assembly of the product.

## Safety Rules for Assembly

### **\* Important Safety Instructions \***

This manual must be kept in a location where it is readily available to persons who are skilled and experienced in the assembly, maintenance, or repair of the QuadGuard® Elite M10. Additional copies of this manual are available from Valtir by calling (888) 323-6374 or at [Valtir.com/Contact](http://Valtir.com/Contact). Please contact Valtir if you have any questions concerning the information in this manual or about the QuadGuard® Elite M10.

It is the responsibility of the installer to use appropriate safety precautions when operating power equipment, mixing chemicals, and when moving heavy equipment or QuadGuard® Elite M10 components. Safety articles including but not necessarily limited to work gloves, eye protection, safety-toe shoes, and back protection should be used.



**Warning:** It is the responsibility of the installer to use all safety measures incorporating appropriate traffic control devices specified by the highway authority. These measures must be used to protect all personnel while at the assembly, maintenance, or repair site.



**Warning:** Failure to comply with these warnings could result in increased risk of serious injury or death in the event of a vehicle impact with a system that has not been accepted by the FHWA.



**Warning:** Use only Valtir parts on the QuadGuard® Elite M10 for assembly, maintenance, or repair. The use of component parts not specified herein is **strictly prohibited**. The QuadGuard® Elite M10 assembled with Valtir Parts has been tested, approved, and accepted for state use by the FHWA. A QuadGuard® Elite M10 Assembly using parts other than those specified herein has not been tested, approved, or accepted for state use by the FHWA. Failure to follow this warning could result in increased risk of serious injury or death in the event of a vehicle impact.

## **Limitations and Warnings**

Valtir contracts with independent crash testing facilities to test and prepare crash test reports for FHWA review.

The QuadGuard® Elite M10 has been deemed eligible for reimbursement by the FHWA as meeting the requirements and guidelines of MASH. These tests evaluate product performance defined by AASHTO involving lightweight cars (approx. 2420 lb. [1100 kg]) and full size pickup trucks (approx. 5000 lb. [2270 kg]). A product can be certified for multiple Test Levels. The QuadGuard® Elite M10 Wide is certified to the Test Level(s) as shown below:

### **Test Level 3: 62 mph [100 kph]**

**These AASHTO directed tests are not intended to represent the performance of systems when impacted by every vehicle type or every impact condition existing on the roadway. This system is tested only to the test matrix criteria of MASH as approved by FHWA.**

Valtir expressly disclaims any warranty or liability for injury or damage to persons or property resulting from any impact, collision or harmful contact with products, other vehicles, or nearby hazards or objects by any vehicle, object or person, whether or not the products were assembled in consultation with Valtir or by third parties.

The QuadGuard® Elite M10 system is intended to be assembled, delineated, and maintained within specific state and federal guidelines. It is important for the highway authority specifying the use of a highway product to select the most appropriate product configuration for site specifications. The customer should be careful to properly select, assemble, and maintain the product. Careful evaluation of site layout, traffic speed/type, direction, and visibility are some of the elements that require evaluation by the highway authority in the selection of a highway product. For example, curbs could cause an untested effect on an impacting vehicle.

After an impact occurs, the debris from the impact should be removed from the area immediately and the specified highway product should be evaluated and restored to its original specified condition or replaced as the highway authority determines as soon as possible.



**Warning:** Do not assemble, maintain, or repair the QuadGuard® Elite M10 until you have read this manual thoroughly and completely understand it. Ensure that all Danger, Warning, Caution, and Important statements within the manual are completely followed. Please call Valtir at (888) 323-6374 if you do not understand these instructions.



**Warning:** Ensure that all of the QuadGuard® Elite M10 Danger, Warning, Caution, and Important statements within the QuadGuard® Elite M10 manual are completely followed. Failure to follow this warning could result in serious injury or death in the event of a collision.

## **System Overview**

The QuadGuard® Elite M10 is a potentially reusable, re-directive, non-gating crash cushion for roadside features of 24" [610 mm] or less in width with use of an approved transition. It consists of energy-absorbing high density polyethylene cylinders surrounded by a framework of Quad-Beam Fender Panels.



**Important:** Valtir makes no recommendation whether use or reuse of any part of the system is appropriate or acceptable following an impact. It is the sole responsibility of the project engineer and/or the local highway authority and its engineers to make that determination. It is critical that you inspect this product after assembly is complete to make certain that the instructions provided in this manual have been strictly followed.

The QuadGuard® Elite M10 system utilizes two types of Cylinders in a “staged” configuration that are designed and tested to address vehicles as defined by MASH for both lighter cars and heavier, high center-of-gravity vehicles.

### **Impact Performance**

The **8 Bay** QuadGuard® Elite M10 systems have successfully passed the requirements stipulated in MASH, Test Level 3 tests with both the light car and pickup trucks at speeds of up to **62 mph [100 kph]** at redirection impact angles up to 25 degrees.

During head-on impact testing, within MASH criteria, the QuadGuard® Elite M10 has been shown to telescope rearward to absorb the energy of impact. When impacted from the side, within the applicable MASH criteria, it has been shown to redirect the vehicle back toward its original travel path and away from the highway feature.



**Warning:** It is the sole responsibility of the project engineer and/or local highway authority and its engineer to ensure that the QuadGuard® Elite M10 and delineation used meet all federal, state, specifying agency, and local specifications.



**Warning:** It is the sole responsibility of the project engineer and/or local highway authority and its engineer to ensure that the QuadGuard® Elite M10 meets all appropriate MUTCD and local standards.

### **Inspect Shipping**

Check the received parts against the shipping list supplied with the system before deploying the QuadGuard® Elite M10. Make sure all parts have been received.



**Important:** The Manufacturer’s Drawing Package supplied with the QuadGuard® Elite M10 must be used with these instructions for proper assembly and should take precedence over these general instructions.



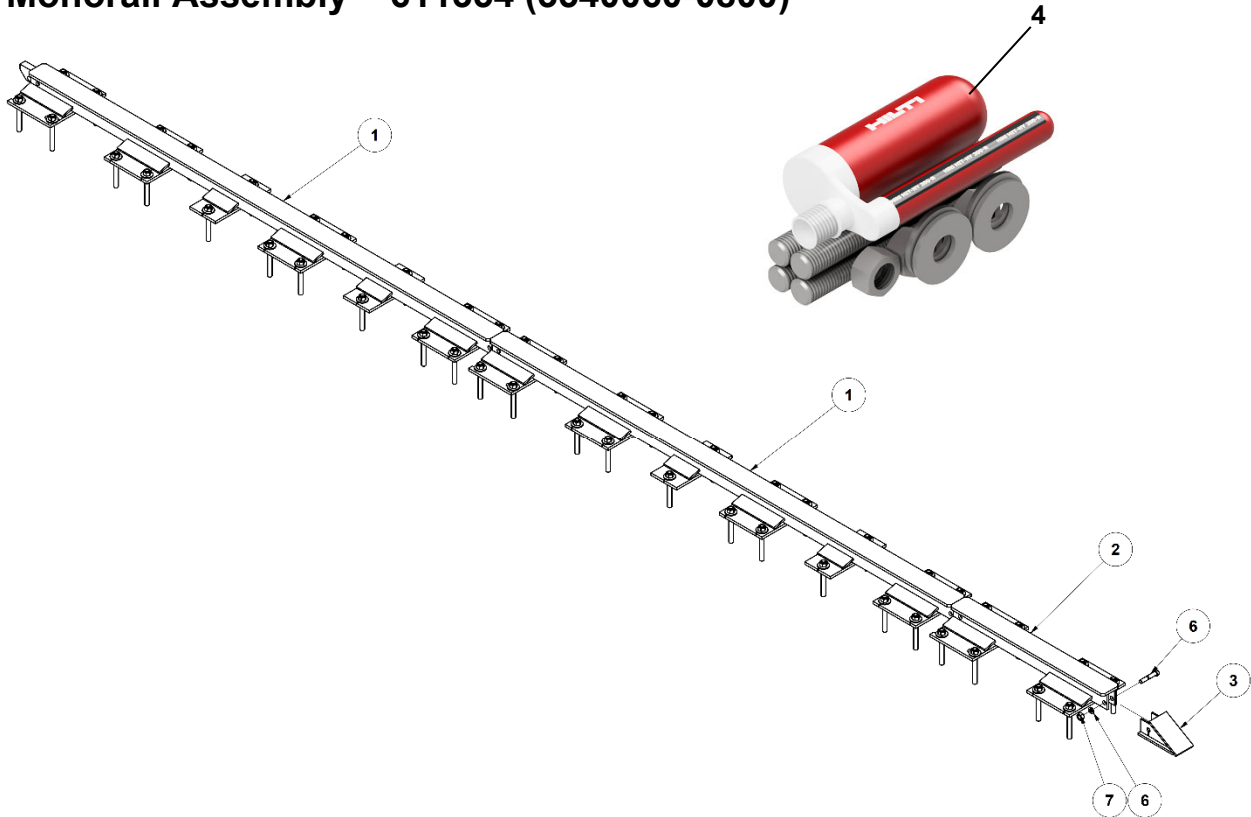
**Warning:** Do NOT modify the QuadGuard® Elite M10 in any way.

## System Assemblies

System assemblies that may be ordered in your particular QuadGuard® Elite M10 configuration. Verify parts delivered and system details with the BOM (Bill of Materials) and system drawings shipped with your system. Please call Valtir if you have any system questions (p. 3).

**Note:** Parts and Assemblies are not shown to scale.

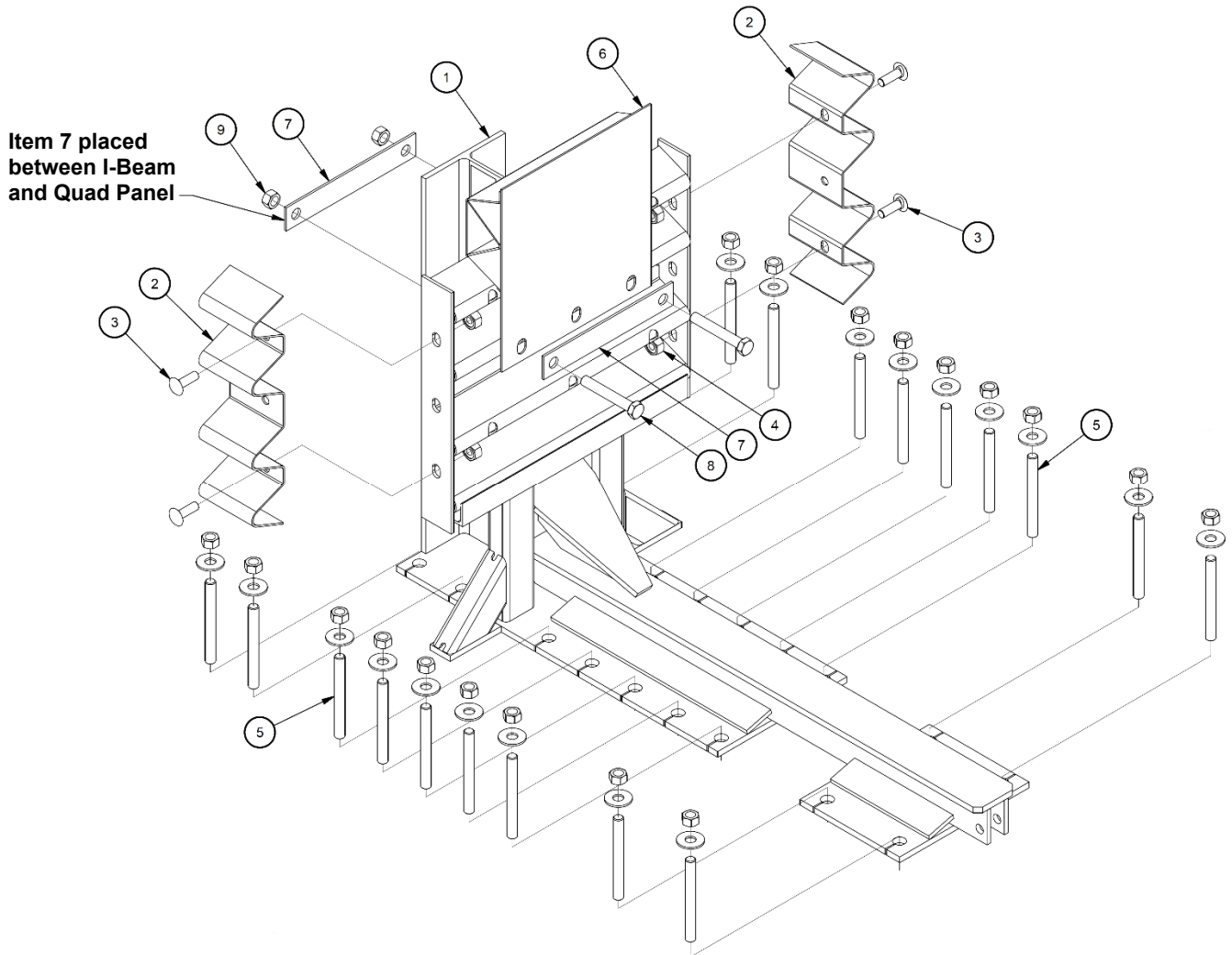
### Monorail Assembly – 611354 (3540060-0800)



Item	PN	EAS PN	Description	Qty
1	611379	2760071-0000	Monorail, 3 Bay	2
2	611370	2760051-0000	Monorail, 1 Bays	1
3	608136	2760041-0000	Endcap, Monorail	1
4	619316	619316	Anchor Kit, Hilti, 330 ml, 3/4x7 (4)	12
5	113660	2699571-0000	Bolt, Hex, 5/8x3 1/2, G5	1
6	118100	2708231-0000	Washer, Lock, 5/8	1
7	003354	2704141-0000	Nut, Heavy Hex, 5/8, A563	1

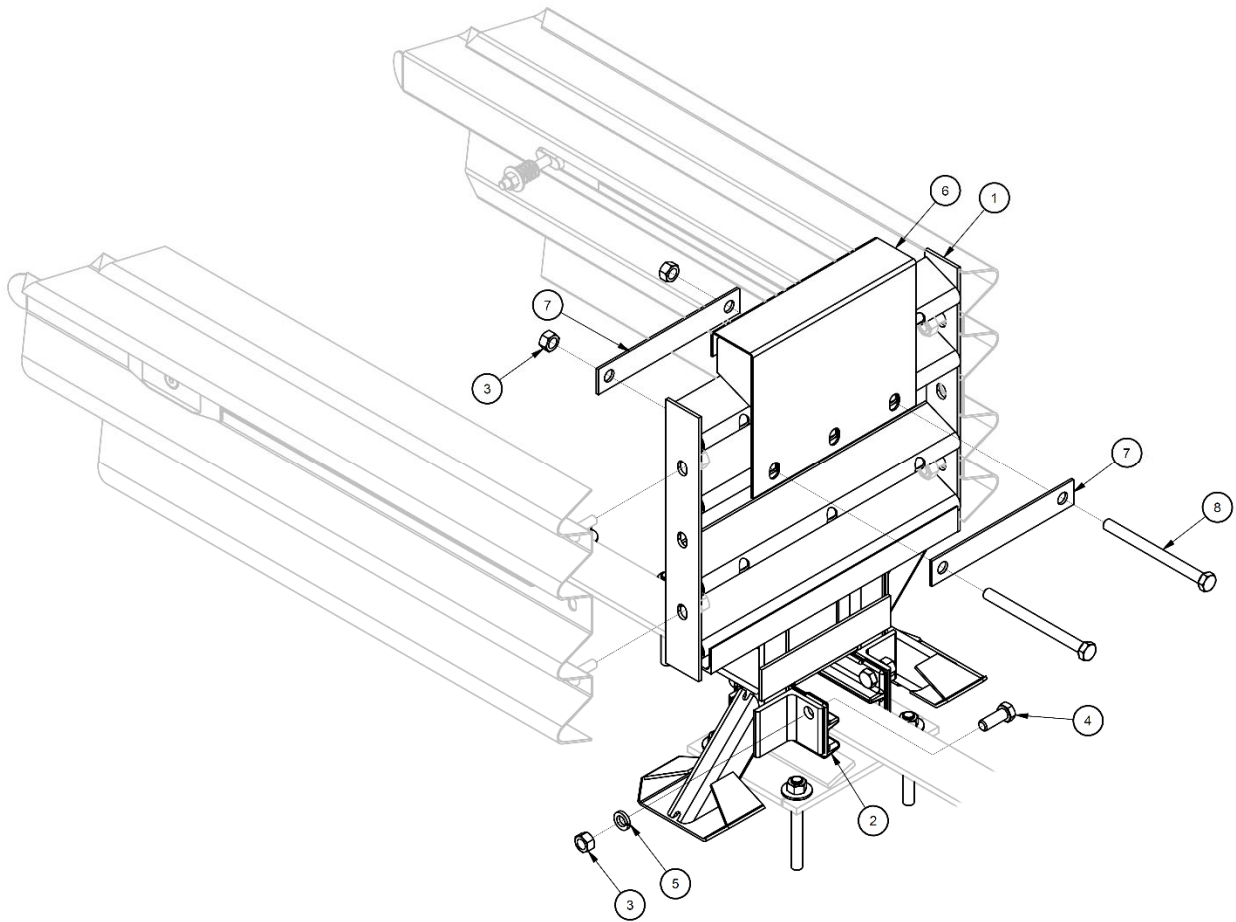


## Backup Assembly - 618857



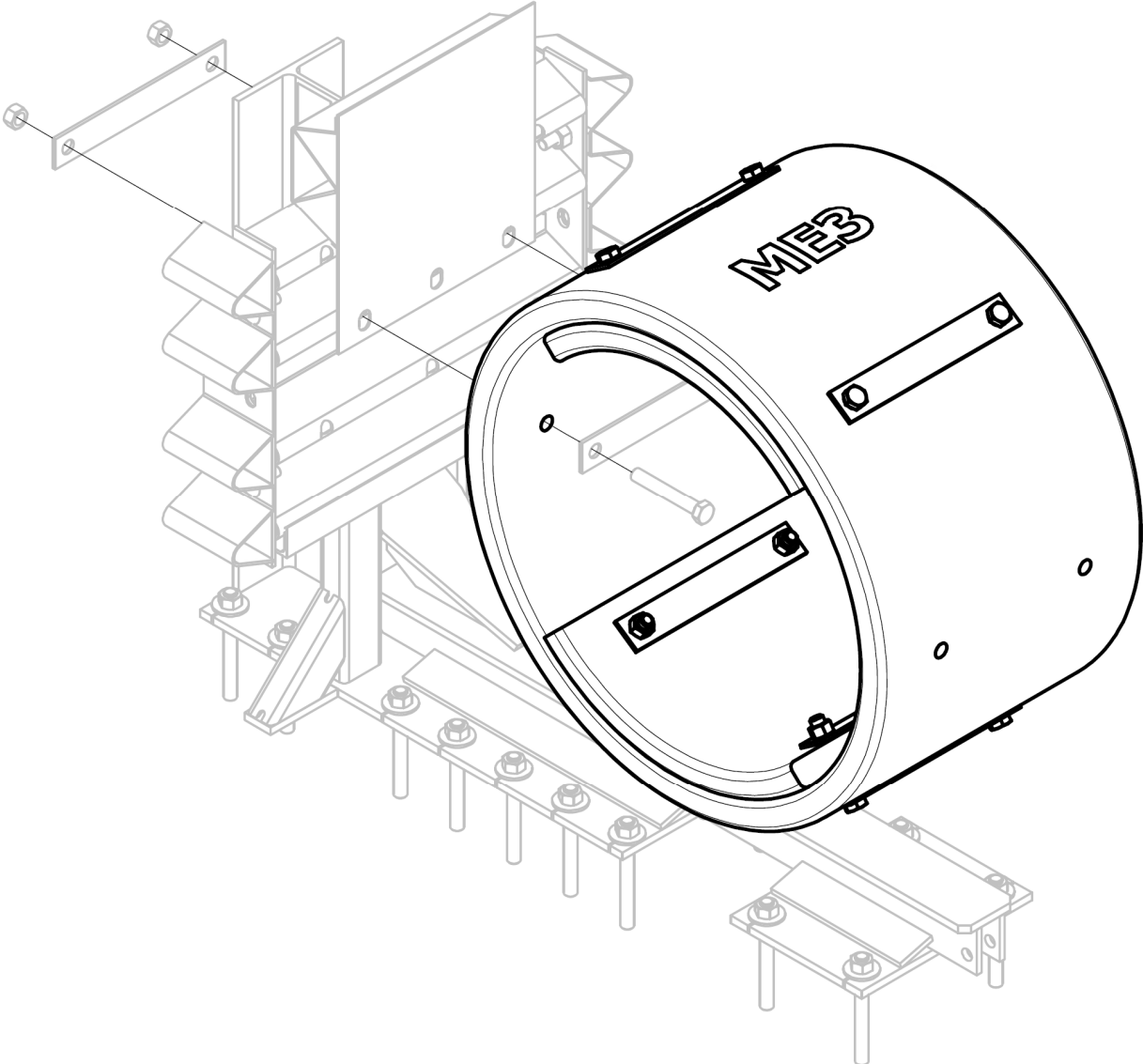
Item	PN	EAS PN	Description	Qty
1	618844	618844	Backup, TS, 24, QGE, W/Decal	1
2	611898	2760141-0000	Panel, Side, QG	2
3	003400	2699341-0000	Bolt, Rail, 5/8x2	4
4	003340	2704191-0000	Nut, Hex, 5/8, Rail	4
5	619316	619316	Anchor Kit, Hilti, 330 ml, 3/4x7 (4)	5
6	618536	618536	Extension, Backup, M10, QGE	1
7	618652	618652	Flt St 3/16x2x13, W/Holes	2
8	113573	2698015-0000	Bolt, Hex, 3/4x5, G5	2
9	003704	2704341-0000	Nut, Hex, 3/4, A563 DH	2

## Diaphragm Assembly – 619133

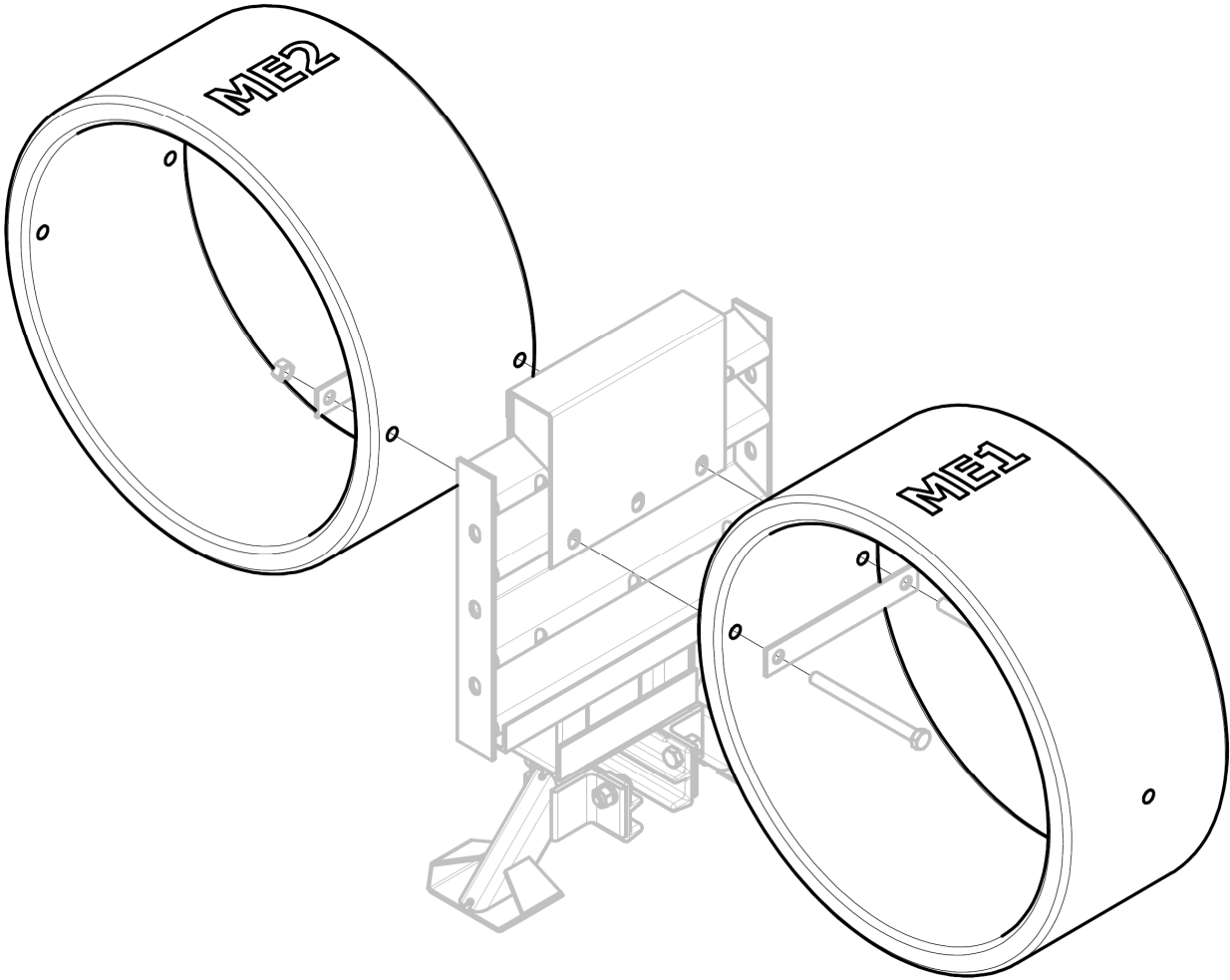


Item	PN	EAS PN	Description	Qty
1	625647	625647	Diaphragm, 24	1
2	611368	2760091-0000	Monorail Guide	2
3	003704	2704341-0000	Nut, Hex, 3/4 Heavy, A563 DH	6
4	113555	2699121-0000	Bolt, Hex, 3/4x2, G8	4
5	118089	2708201-0000	Washer, Lock, 3/4	4
6	618526	618526	Extension, Diaphragm, Angle	1
7	618652	618652	Fit St 3/16x2x13, W/Holes	2
8	118563	118563	Bolt, Hex, 3/4x9, G5	2

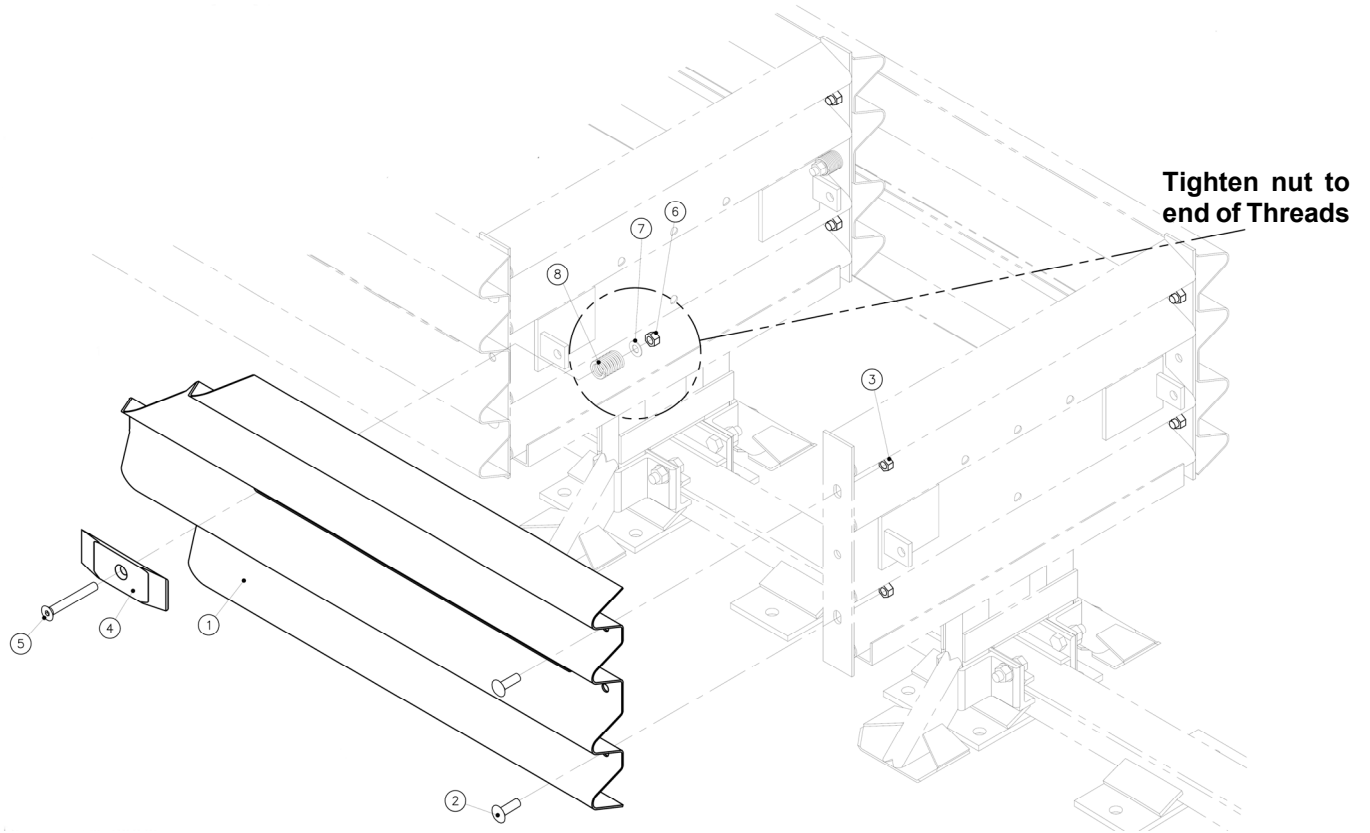
**ME3 Cylinder Assembly – 618702**



**ME2 Cylinder Assembly – 618649 & ME1 Cylinder Assembly - 618538**



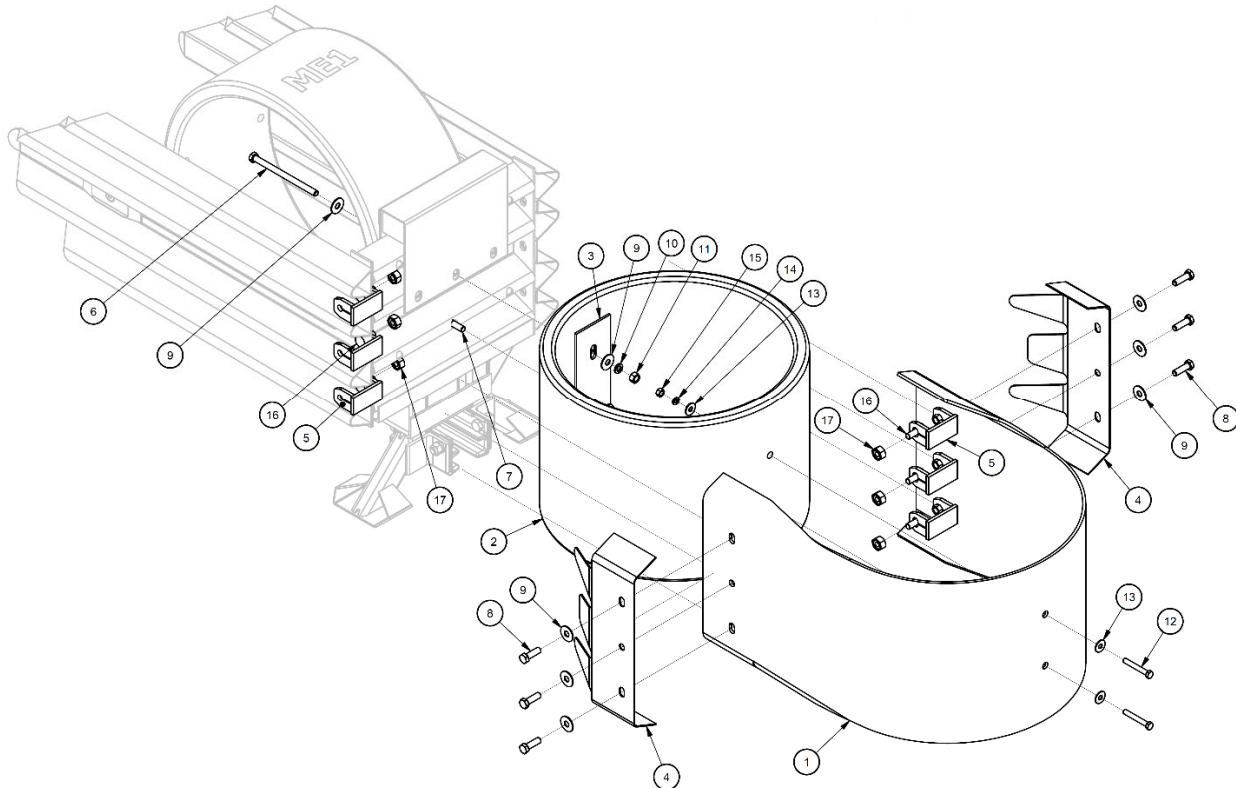
## Fender Panel Assembly (2 per Bay) – 608235 (3540585-0000)



Item	PN	EAS PN	Description	Count
1	611832	2760081-0000	Fender Panel	1
2	118614	118614	Bolt, Rail, 5/8x2, G5	2
3	003340	2704191-0000	Nut, Hex, 5/8 Rail	2
4	617045	2708841-0000	Washer, Mushroom	1
5	116878	2706604-0000	Screw, Flat, 5/8x5, G8, Socket	1
6	003354	2704141-0000	Nut, Hex Heavy, 5/8, A563A	1
7	003300	2708291-0000	Washer, Flat, 5/8x1 3/4	1
8	117459	2715343-0000	Spring, Die, 1 1/4 ODx5/8x1 1/2	1

## Nose Assembly – 627522

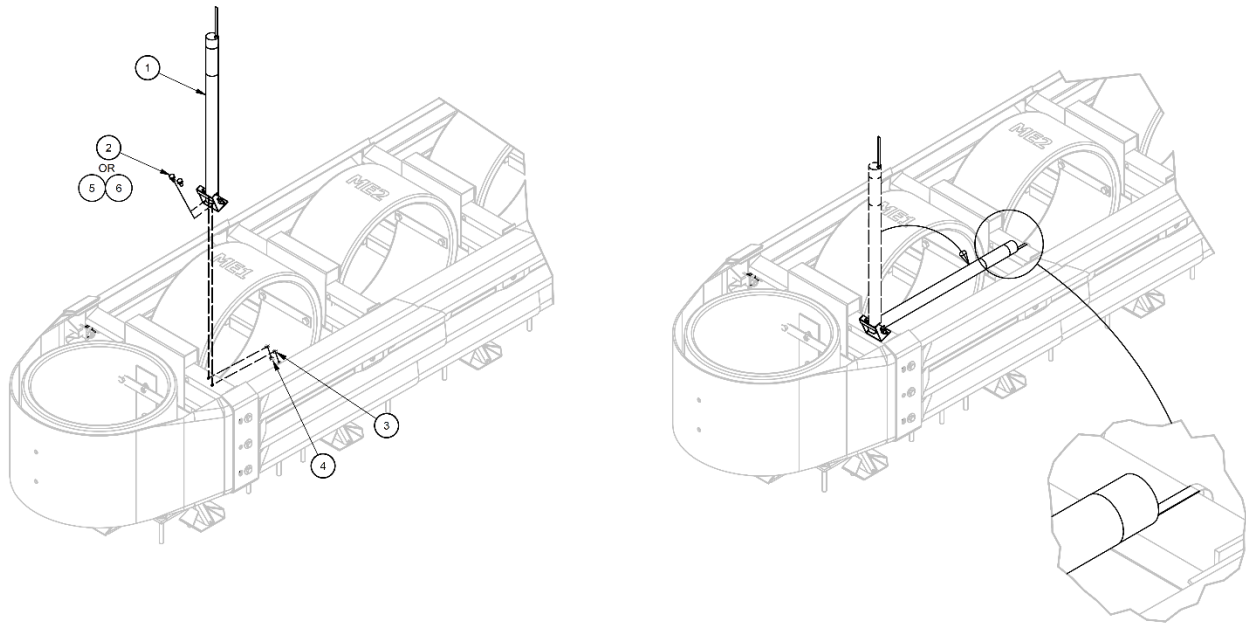
Assembly No.	PN	Description	Width
618842	605099	Belt, Nose, 84 5/8, Gray	24.0" (610 mm)
618843	605100	Belt, Nose, 84 5/8, Yellow	24.0" (610 mm)



Item	PN	EAS PN	Description	Qty
1	See Table		Belt, Nose, 84 5/8, QGE, 24, G or Y	1
2	606689	2021657-0000	Cylinder, Nose, HDPE, 28x20	1
3	612253	2753071-0000	Plate, Nose Cylinder	1
4	606330	2760504-0000	Clamp, Nose Belt	2
5	614666	2760009-0000	Stop, Tab, Wrap, Weldment	6
6	004489	004489	Bolt, Hex, 5/8x9, A325	1
7	113660	2699571-0000	Bolt, Hex, 5/8x3 1/2, G5	1
8	118570	118570	Bolt, Hex, 5/8x2, G5	6
9	003300	2708291-0000	Washer, Flat, 5/8x1 3/4	9
10	118100	2708231-0000	Washer, Lock, 5/8	2
11	003354	2704141-0000	Nut, Hex, 5/8 Heavy, A563A	2
12	113474	2698181-0000	Bolt, Hex, 1/2x3 1/2, G5, Fully Threaded	2
13	118009	2708011-0000	Washer, Flat, 1/2x1 3/8	4
14	118082	2708181-0000	Washer, Lock, 1/2	2
15	115939	2704011-0000	Nut, Hex, 1/2	2
16	118614	118614	Bolt, Rail, 5/8x2, G5	6
17	003340	2704191-0000	Nut, Hex, 5/8 Rail	6

**Note:** Contact Customer Service for other color options (p. 3).

## Hit Indicator - 610237



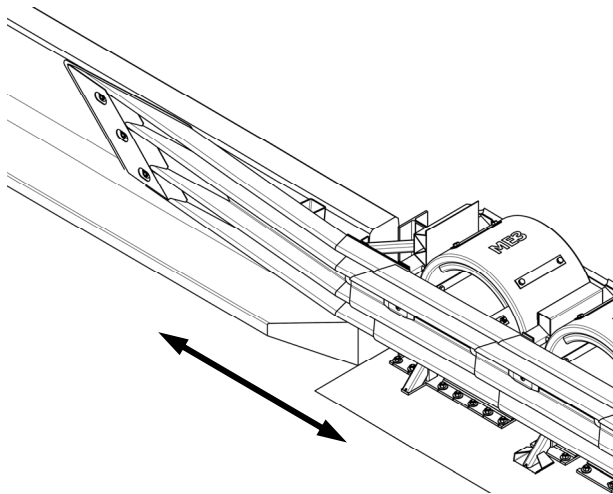
Item	PN	EAS PN	Description	Qty
1	610238	3540462-0000	Hit Indicator	1
2	113467	2701111-0000	Bolt, Hex, 1/2x1, G5	2
3	118082	2708181-0000	Washer, Lock, 1/2	2
4	115939	2704011-0000	Nut, Hex, 1/2	2
5	116891	2706451-0000	Screw, HWH, 1/4x1, Self-Drill/Tap	2
6	118013	2708101-0000	Washer, Flat, 1/4x1	2

## Select Transition

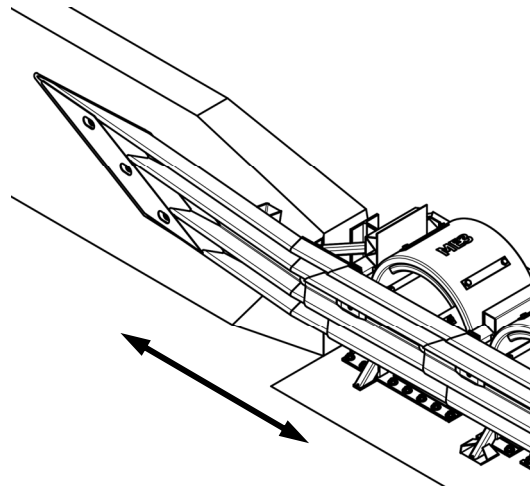
**Note:** A proper Transition Panel or Side Panel must be used on each side of the Backup. A Side Panel is not needed when a Transition Panel is used. Several types of transitions are available for use with the QuadGuard® Elite M10 (Figures 1 – 5). The correct Panel(s) to use will depend on the direction of traffic and what type of barrier or road feature the QuadGuard® Elite M10 is shielding. Contact Customer Service prior to deployment if you have any questions (p. 3).



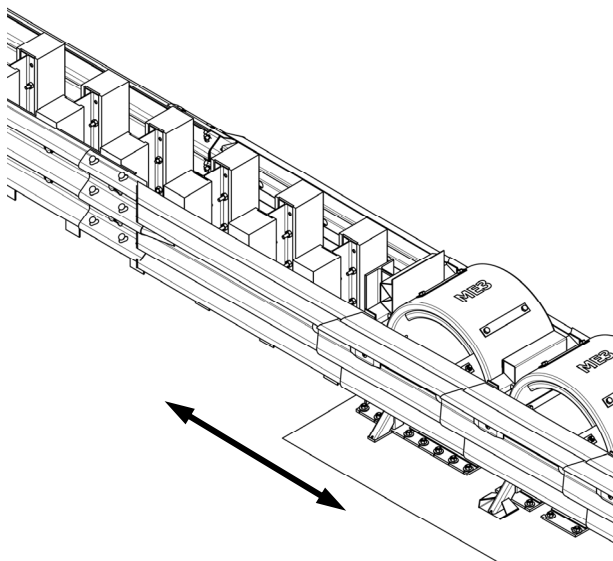
**Important:** The QuadGuard® Elite M10 is available with transitions to concrete barrier, guardrail, and other roadside features.



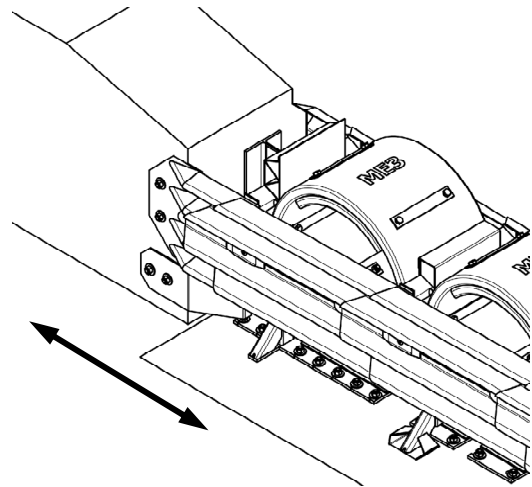
**Figure 1**  
Safety Shape Barrier, 4" Offset



**Figure 2**  
Single Slope Barrier, 6" Offset

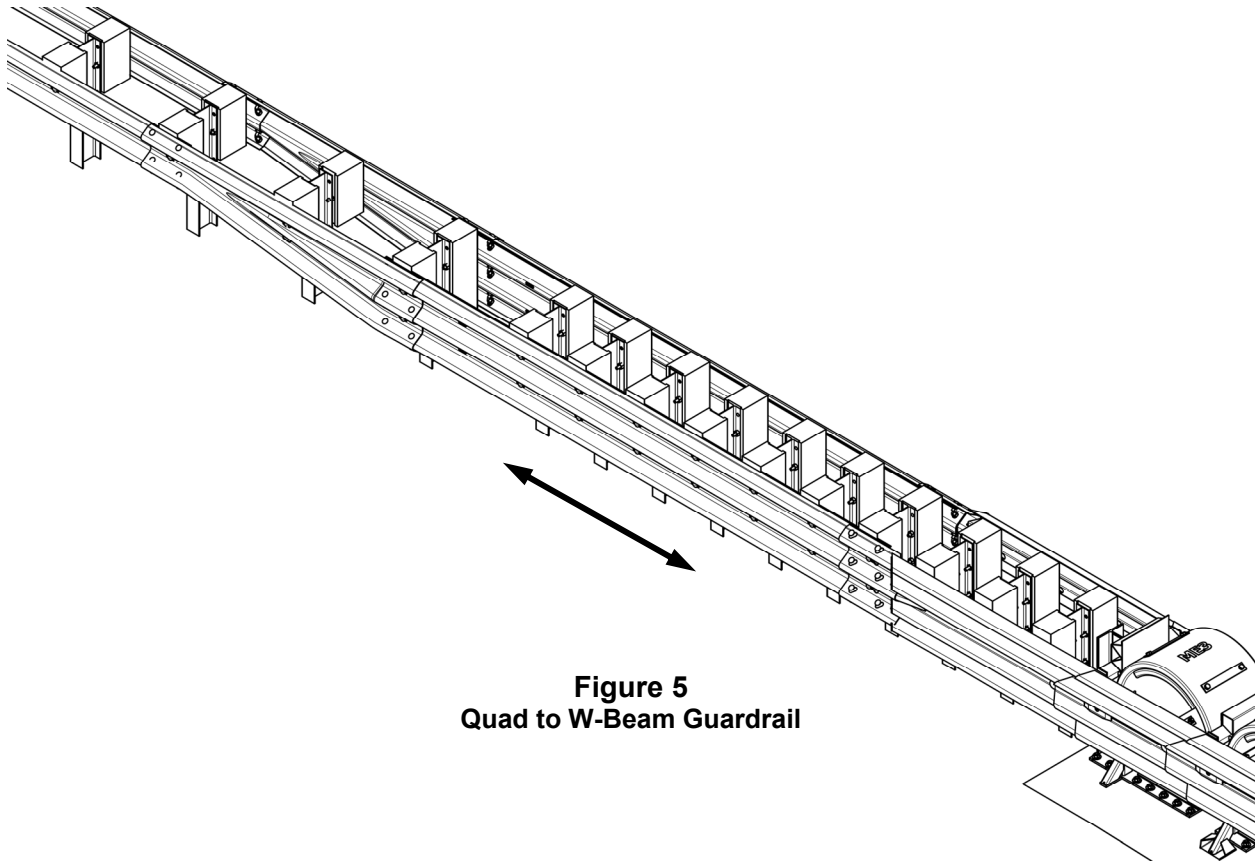


**Figure 3**  
Quad to Thrie-Beam Guardrail



**Figure 4**  
Vertical Wall End Shoe  
With Wheel Deflector





**Figure 5**  
**Quad to W-Beam Guardrail**

## **Recommend Tools**

### **Documentation**

- Manufacturer's Assembly Manual
- Manufacturer's Drawing Package

### **Personal Protective equipment**

- Eye Protection
- Gloves
- Safety Toe Shoes

### **Cutting equipment**

- Rotary Hammer Drill
- Rebar cutting bit
- Concrete drill (Double Fluted\*) bits – 22 mm [7/8"]
- Grinder, Hacksaw or Torch (optional)
- Drill motor
- Drill bits 1/16" through 7/8"



**Important:** Valtir recommends using Double Fluted drills to achieve required tensile strength when assembling the approved anchoring system.

## Hammers

- Sledgehammer
- Standard hammer

## Wrenches

- Heavy duty impact wrench
- Standard adjustable wrench
- 1/2" drive Sockets: 9/16", 11/16", 3/4", 15/16", 1 1/8", 1 1/4"
- 1/2" drive Deep Sockets: 15/16", 1 1/4"
- 1/2" drive Ratchet and attachments
- 1/2" drive Breaker Bar - 24" long
- 1/2" drive Torque Wrench: 200 ft-lb
- Crescent Wrench: 12" [300 mm]
- Allen Wrench: 3/8"
- Impact Wrench: 1/2"



**Important:** Because every impact is different, Valtir makes no recommendation whether use or reuse of any part of the system is appropriate or acceptable following an impact. It is the sole responsibility of the project engineer and/or the local highway authority and its engineers to make that determination. It is critical that you inspect this product after assembly is complete to make certain that the instructions provided in this manual have been strictly followed.

## Miscellaneous

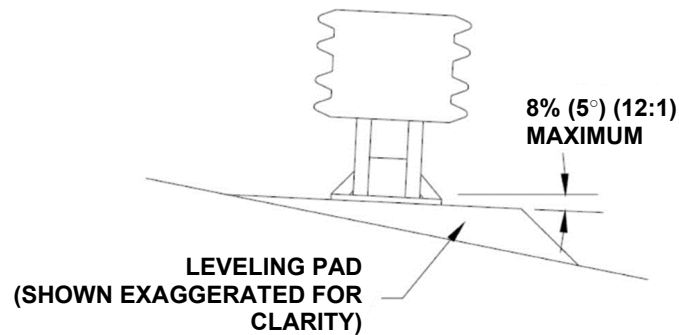
- Traffic control equipment
- Lifting and moving equipment - Minimum 5,000 lb. capacity required
- Air Compressor (100 psi) and Generator (5 kW)
- Pry bar
- Drift pin 300 mm [12"]
- Center punch
- Tape measure 25' [7.5 m]
- Chalk line
- Concrete marking pencil
- Nylon bottle brush for cleaning 7/8" drilled holes
- Rags, water, and solvent for touch-up
- Chain, 3/8" grade 40, 20' [6 m] with 1/2" [13 mm] hooks
- Acetylene torch

**Note:** The above list of tools is a general recommendation and should not be considered an extensive list. Depending on specific site conditions and the complexity of the assembly specified by the appropriate highway authority, the required tools may vary. Decisions as to what tools are needed to perform the job are entirely within the discretion of the specifying highway authority and the authority's selected contractor performing the assembly of the system at the authority's specified assembly site.

## Site Preparation/Foundation

A QuadGuard® Elite M10 should be assembled on an existing or freshly placed and cured concrete foundation (4000 psi [28 MPa] minimum). Location and orientation of the concrete base and attenuator must comply with project plans or as otherwise determined by the resident project engineer.

Recommended dimension and reinforcement specifications for new concrete foundations are provided in Valtir Concrete Foundation drawing, supplied with the system. The system may only be assembled on reinforced concrete roadway (minimum 6" [150 mm] thick). Assembly cross-slope shall not exceed 8% and should not twist more than 2% over the length of the system; the foundation surface shall have a light broom finish.



**Figure 6**  
**Cross-Slope**



**Caution:** Accurate placement of all steel rebar is critical to avoid interference with the concrete anchor bolts.



**Warning:** Location of the Backup in relation to nearby objects will affect the operation of the attenuator. Upon impact, the Fender Panels telescope rearward and extend beyond the rigid Backup as much as 25" [635 mm]. Position the Backup so that the rear ends of the last Fender Panels are a minimum of 25" [635 mm] forward of objects that would otherwise interfere with movement of the rearmost Fender Panels. Failure to comply with this requirement is likely to result in system performance which has not been crash tested pursuant to MASH criteria and may also cause component damage which will necessitate maintenance or replacement of the system.



**Warning:** Ensure that there is proper site grading for the QuadGuard® Elite M10 placement as dictated by the state or specifying agency pursuant to the AASHTO Roadside Design Guide.

## **Foundation/Anchoring**



**Warning:** It is the responsibility of the local DOT or appropriate highway authority to ensure that this assembly conforms to the AASHTO Roadside Design Guide.



**Warning:** It is the responsibility of the installer to ensure that your assembly procedure meets all appropriate Occupational Safety and Health Administration (“OSHA”) and local standards.

### **Asphalt Installations**

Systems with a Tension-Strut Backup may be temporarily installed in construction zones on asphalt. Assemblies on **Asphalt Concrete (“A.C.”)** must provide a minimum of 3” [76 mm] layer of asphalt over a minimum of 3” [76 mm] layer of **Portland Cement Concrete (“P.C.C.”)**, 6” [152 mm] layer of asphalt over 6” [152 mm] layer of subbase, or 8” [200 mm] layer of asphalt with no subbase.



**Important:** Only 18” [460 mm] threaded rods, utilizing Valtir approved adhesive, can be used with **asphalt** foundations (p. 20). Contact Valtir for a complete list of approved adhesives (p. 3).

### **Concrete Installations**

For concrete installations, the QuadGuard® Elite M10 system should be installed only on an existing or freshly placed and cured concrete base (4000 psi [28 MPa] minimum). Orientation of the concrete base and the attenuator must comply with the project plans or as otherwise determined by the resident project engineer or appropriate highway authority.

Recommended dimension and reinforcement specifications for new concrete pads can be found on the standard drawings.

The QuadGuard® Elite M10 may be installed on any of the following foundations using the specified anchorage:

#### **Foundation A: Reinforced Concrete Pad or Roadway**

Foundation: 6” [152 mm] minimum depth P.C.C.

Anchorage: Approved adhesive with 7” [180 mm] studs at 5 1/2” [140 mm] embedment

#### **Foundation B: Asphalt over P.C.C.**

Foundation: 3” [76 mm] minimum asphalt concrete (A.C.) over 3” [76 mm] minimum P.C.C.

Anchorage: Length of anchor required is 18” [460 mm] studs at 16 1/2” [420 mm] embedment

#### **Foundation C: Asphalt over Subbase**

Foundation: 6” [152 mm] minimum A.C. over 6” [152 mm] minimum Compacted Subbase (C.S.)

Anchorage: Approved adhesive with 18” [460 mm] studs at 16 1/2” [420 mm] embedment

#### **Foundation D: Asphalt Only**

Foundation: 8” [200 mm] minimum A.C.

Anchorage: Approved adhesive with 18” [460 mm] studs at 16 1/2” [420 mm] embedment

## Valtir Approved Adhesive Anchoring System

A Valtir approved adhesive anchoring system is required to securely anchor crash cushions. Each approved adhesive kit contains adhesive, studs, nuts and washers. Both vertical and horizontal assemblies are possible using an approved adhesive anchoring system.

### Vertical Anchors

**Note:** Read all Valtir approved adhesive instructions before starting.

#### 1) Prepare the Concrete Foundation



**Warning:** Do not allow anchoring adhesive to contact skin or eyes. See material safety data sheet supplied with adhesive kit for first-aid procedures. Use only in well-ventilated area. Do not use near open flame.



**Warning:** It is the responsibility of the installer to maintain a safe work area including the use of standard work zone safety equipment & PPE: gloves, safety-toe shoes, and eye / ear protection.

The anchor bolts (studs) that anchor the QuadGuard® Elite M10 Backup and/or Monorail sections to the concrete foundation must be those shipped in the kit or of high strength steel (120,000 psi [830 MPa] minimum tensile strength or equal). These studs must be set in minimum 4000 psi [28 MPa] concrete. Allow the concrete to cure a minimum of seven days before applying anchoring adhesive.

#### 2) Drill Boreholes



**Caution:** It is the responsibility of the installer to consult OSHA silica respiratory standard 29 CFR 1910.134 for debris removal from borehole(s) and use Valtir approved adhesive to achieve optimum tensile strength. Do not use diamond drill bits for drilling boreholes.

Use the Monorail(s) and Tension Strut Backup as drilling templates. Use a rotary hammer drill to drill the boreholes 7/8" [22 mm] diameter to the recommended depth. See the approved adhesive instructions provided with adhesive kit. Check to ensure each borehole is drilled to the proper depth and aligned with the part to be anchored per Anchoring Information table.

Anchor Information					
Stud Size	Orientation	Bit Size	Minimum Depth	Torque	Medium
3/4x6 1/2"	Horizontal	7/8" [22 mm]	5 1/4" [125 mm]	100 ft-lb [136 N-m]	Concrete
3/4x7"	Vertical	7/8" [22 mm]	5 3/4" [146 mm]	100 ft-lb [136 N-m]	Concrete
3/4x18"	Vertical	7/8" [22 mm]	16 3/4" [425 mm]	10 ft-lb [15 N-m]	Asphalt



**Important:** When mounting on asphalt, initial torque shall be as shown above. Due to the properties of asphalt, anchors may loosen over time. For this reason, Valtir recommends anchoring to asphalt only at temporary locations. It is recommended to re-torque anchors in asphalt every six (6) months to 10 ft-lb.

### 3) Clean the Boreholes

Blow the concrete dust from the borehole using (90 psi) oil-free compressed air. Thoroughly brush the borehole with a 7/8" diameter steel bristle tube brush and then blow it out again. If the borehole is wet, completely flush it with water while brushing and then blow it clean to remove all water using oil-free compressed air.

**Note:** Use of the Valtir approved vacuum drilling equipment is authorized to replace the blowing and brushing requirement of Step 3.

### 4) Apply Approved Adhesive

Fill the borehole 100% full.



**Caution:** Fill borehole 100% full so it is even with the pavement surface per the adhesive manufacturer's instructions.

### 5) Add the Washers and Nuts

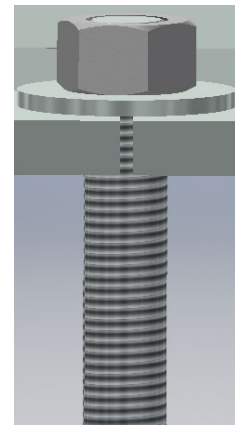
Place a flat washer onto the stud then thread a nut on until the end of the stud is flush with the nut (Figure 7).

### 6) Insert Studs in Boreholes and Wait for Adhesive to Cure

Push the stud down through the part to be anchored and into the borehole.



**Warning:** Do not disturb or load the stud until the approved adhesive material has fully cured (reference instructions supplied with the approved adhesive kit).



**Figure 7**  
**Anchor Application**  
**(Before Applied Torque)**

### 7) Torque the Nuts

Once the adhesive has fully cured, torque each nut to 100 ft-lb.

## Anchor Assembly Cautions for Steel Rebar

If steel rebar is encountered while drilling an anchor bolt borehole, apply one of the following solutions:

- 1) Use a rebar drill bit for the **rebar only** and then switch back to the concrete bit to finish drilling into the underlying concrete until the proper borehole depth is reached.



**Caution:** Do not drill through rebar without first obtaining permission to do so from the project engineer.

- 2) Drill a new borehole down at an angle past the rebar to the proper depth. Anchor the stud by completely filling both boreholes with an approved adhesive.

## Horizontal Anchors

The horizontal approved adhesive kit is the same as the vertical kit.



**Caution:** Fill borehole 100% full so it is even with the vertical concrete surface per manufacturer's instructions.

### 1) Follow the instructions supplied with your approved adhesive kit

Apply approved adhesive to each anchor per instructions.

### 2) Add the Washers and Nuts

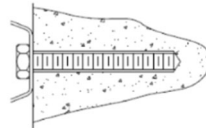
Put washer and nut on stud so the **nut is flush with end of stud**.

### 3) Insert each Stud with Washer and Nut into Borehole

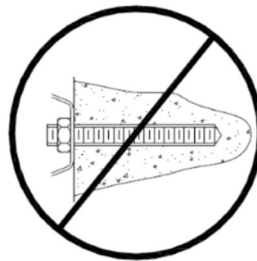
Push stud with washer and nut into borehole.



**Important:** The stud should be flush with the top of the nut in both **vertical** and **horizontal** applications prior to tightening (Figure 8).



CORRECT



INCORRECT

**Figure 8**  
**Horizontal Application**  
**(Before Applied Torque)**



**Caution:** Do not disturb or load the stud until the approved adhesive material has hardened (reference approved adhesive kit instructions for hardening times).

### 4) Torque the nuts

Once the adhesive has fully cured, torque each nut to 100 ft-lb.

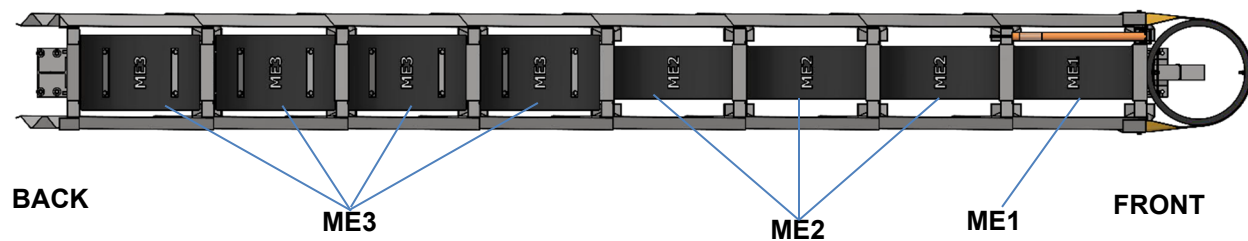


Figure 9 Plan View

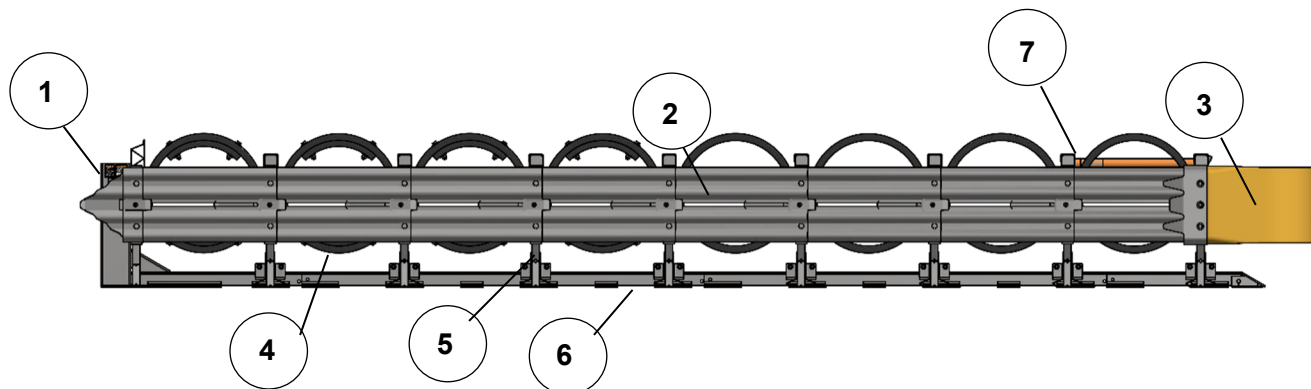


Figure 10 Elevation View

**KEY**

- 1) Backup
- 2) Quad-Beam Fender Panel
- 3) Belt Nose
- 4) Cylinder
- 5) Diaphragm
- 6) Monorail
- 7) Hit Indicator



## How to Determine Left/Right

To determine left from right when ordering parts, stand in front of the system facing the road feature. Your left is the system's left and your right is the system's right.

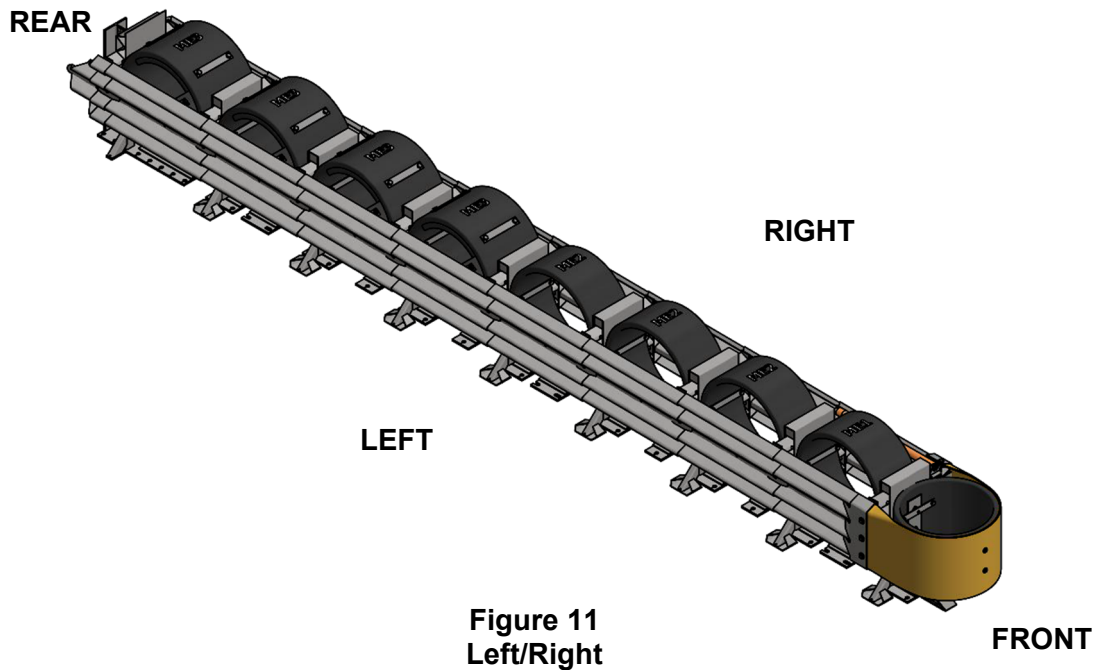


Figure 11  
Left/Right

## Counting the Number of Bays

One Bay consists of one Diaphragm, two Fender Panels, etc. The Nose Assembly is not considered a Bay (Figure 12).

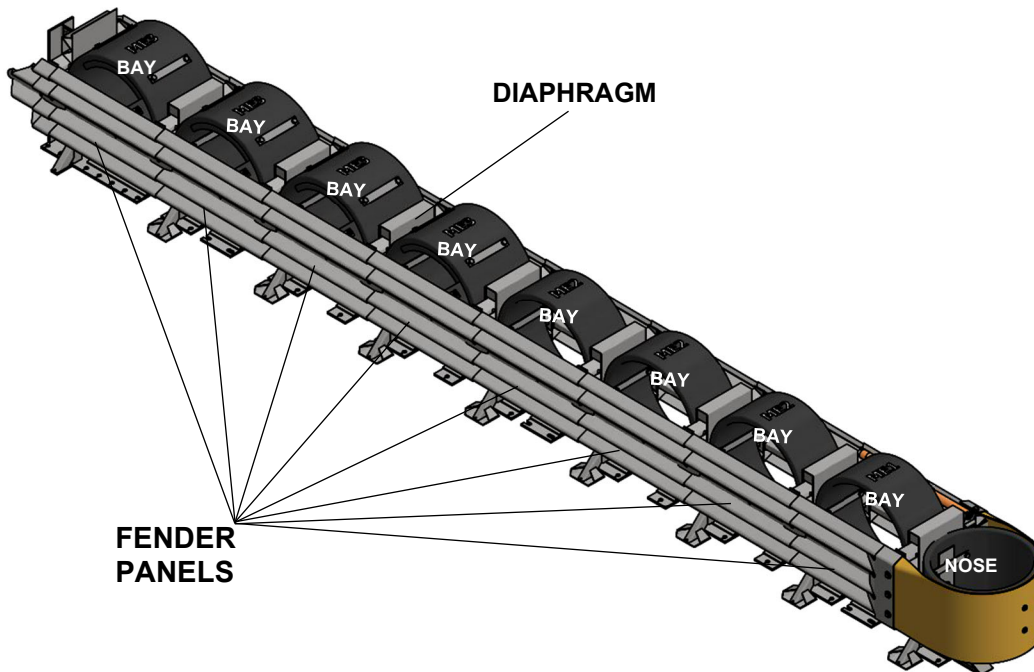


Figure 12  
8 - Bay System

## Measuring the Width

The nominal width of the 24" parallel system is the width of the Backup (Figure 13). The outside width of the system is approximately 6" [152 mm] wider than the nominal width. The outside width of the system is not the same as the width of the Backup.

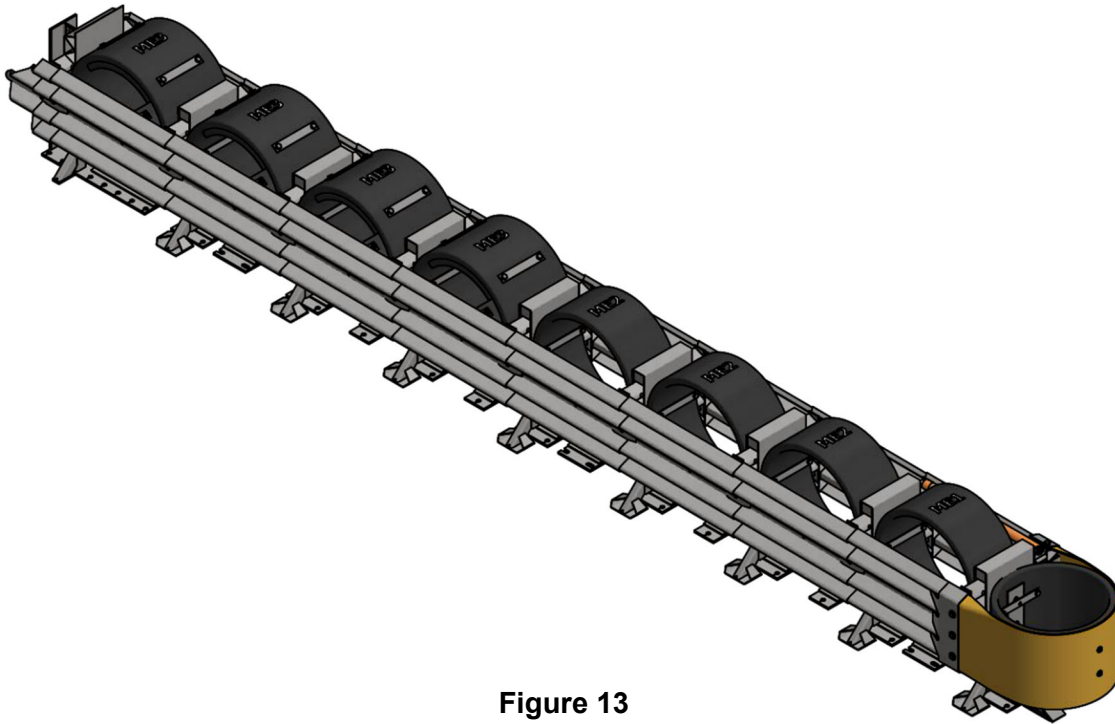


Figure 13  
Width of a Parallel System

QuadGuard® Elite M10 System Chart	
<b>Width</b>	<b>8 Bay - 62 mph [100 kph]</b>
24" [610mm]	QM10024E

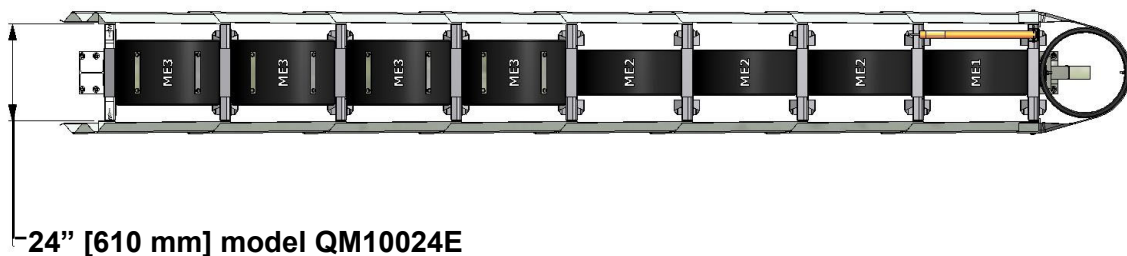


Figure 14  
8 - Bay System

## **Assembly Procedures**

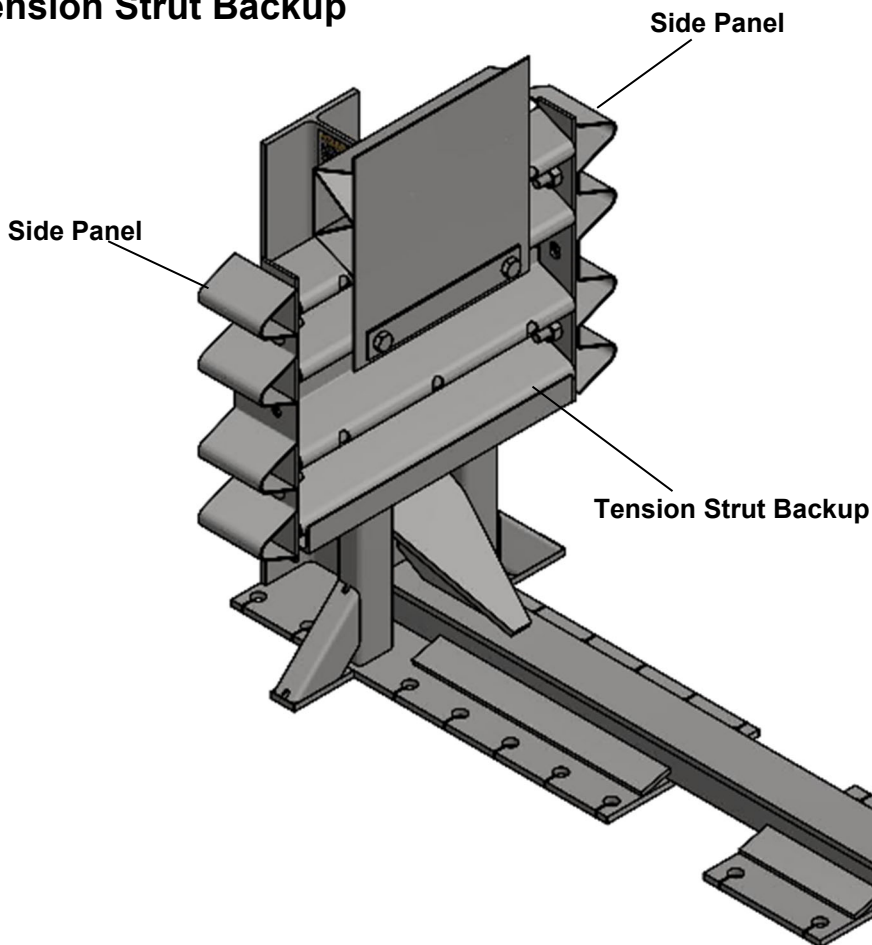
**Note:** The Drawing Package supplied with the QuadGuard® Elite M10 must be used with these instructions for proper assembly and should take precedence over these general instructions.

### **1) Determine Backup & Transition Type**

The QuadGuard® Elite M10 uses a Tension Strut Backup.

A Transition Panel or Side Panel must be used on each side of the Backup (Figure 15). A Side Panel is not needed when a Transition Panel is used. Several transitions are available for the QuadGuard® Elite M10 (pp. 15-16).

### **Tension Strut Backup**



**Figure 15**  
**24" Tension Strut Backup**

## 2) Mark System Location

- A. Locate the centerline of the system by measuring the proper offset from the hazard. See the drawing package supplied with the system.
- B. Mark the centerline of the system with a chalk line.
- C. Mark a construction line parallel to the center line and offset 6.5" [165 mm] to one side as shown in Figure 16.
- D. The edge of the Monorail will be placed on this line.

**Note:** The concrete pad must comply with the Manufacturer's Drawing Package supplied with the system.



**Warning:** Only Strong Soil, AASHTO M147 with static performance >90% is to be used with the assembly of a transition in soil.



**Warning:** Location of system with respect to the hazard is critical and dependent on the type of Transition Panel used. See the project plans supplied with the system for details.



**Figure 16**  
**(Top view of concrete pad)**  
**Locating Construction Line**

### 3) Anchor the Backup and Monorail

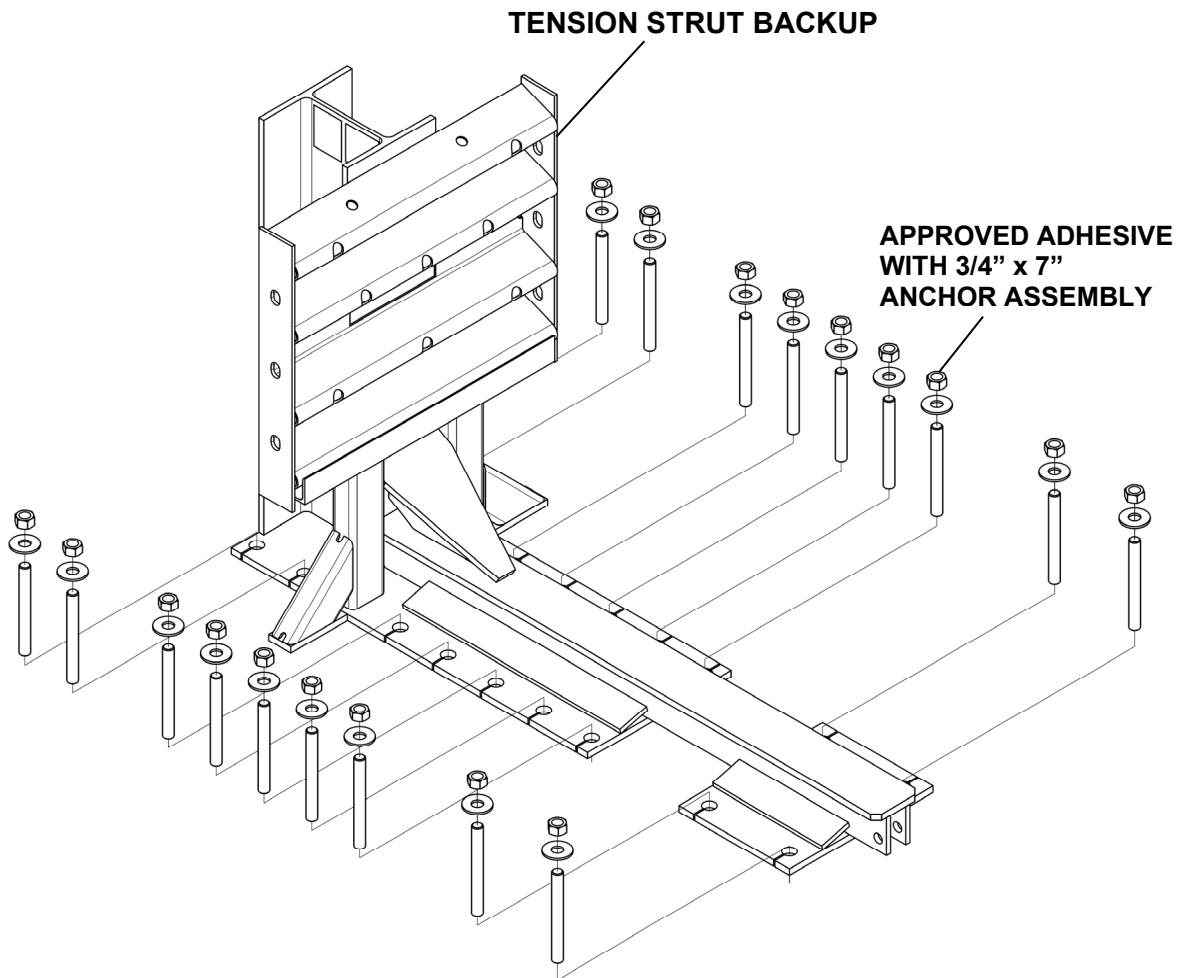
See Figure 17 (showing Backup Assembly) and Figure 19 (showing Monorail deployment). Also refer to the drawing package and the approved anchoring instructions (p. 20).



**Warning:** Location of the system as determined by the proper highway authority is critical and dependent on the type of Transition Panel used. Consult project plans supplied by the applicable highway authority with the system for details.

#### Step 1. Tension Strut Backup Assembly (Figure 17)

Locate the Backup and Monorail on the pad with the side of the Monorail on the construction line (Figure 19). Verify that applicable Transition Panels fit properly before anchoring the Backup. Drill 5 3/4" [146 mm] deep anchor holes in the pad using the Backup as a template. Do not drill through pad. Anchor the Backup to the concrete pad using approved adhesive kits (p. 20).



**Figure 17**  
**Anchoring Tension Strut Backup to Foundation**

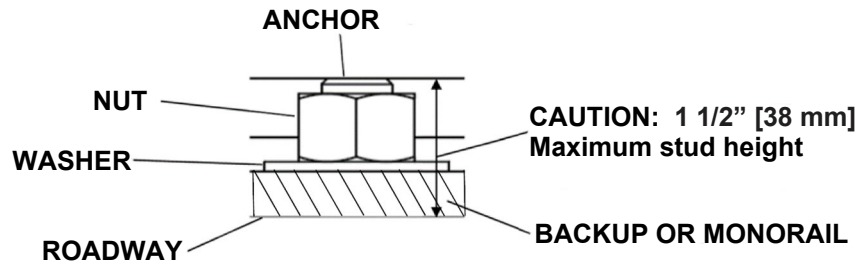
## Step 2. Monorail Assembly

Locate the Monorail on the construction line as shown in the Monorail Assembly drawings. Drill 5 3/4" [146 mm] deep anchor holes using the Monorail as a template (Figure 19). Do not drill through the pad. Anchor each Monorail section using the provided approved adhesive kits.

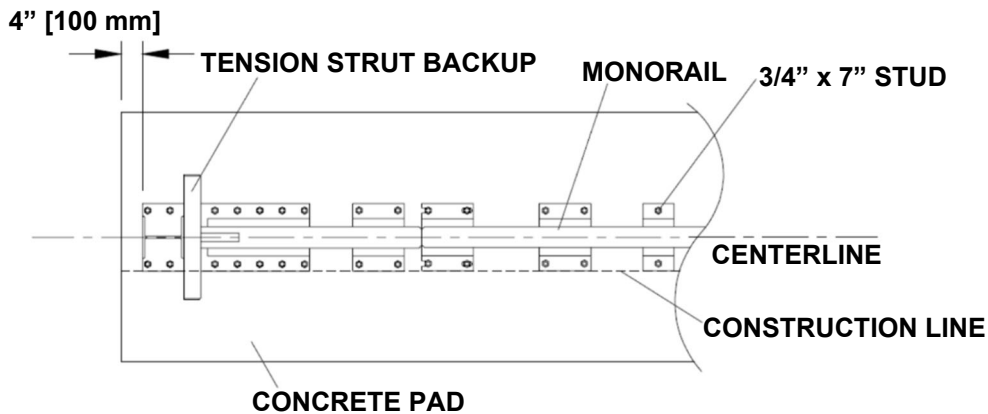


**Warning:** Improper alignment at the Monorail Splice Joints will prevent proper system collapse during an impact.

**Warning:** Every hole and slot in Backup and Monorail must have an approved adhesive stud anchoring it.

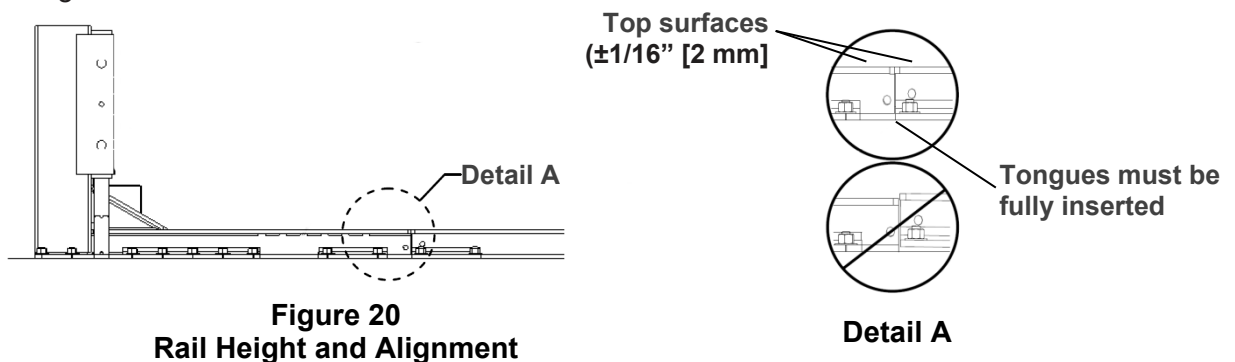


**Figure 18**  
Proper Stud Height



**Figure 19**  
Backup and Monorail Location for Tension Strut Backup

It is important to align each Monorail segment vertically to ( $\pm 1/16$ " [2 mm]) (Detail 16a). Anchor each Monorail section using the provided Valtir approved adhesive kit. Do not drill through foundation.

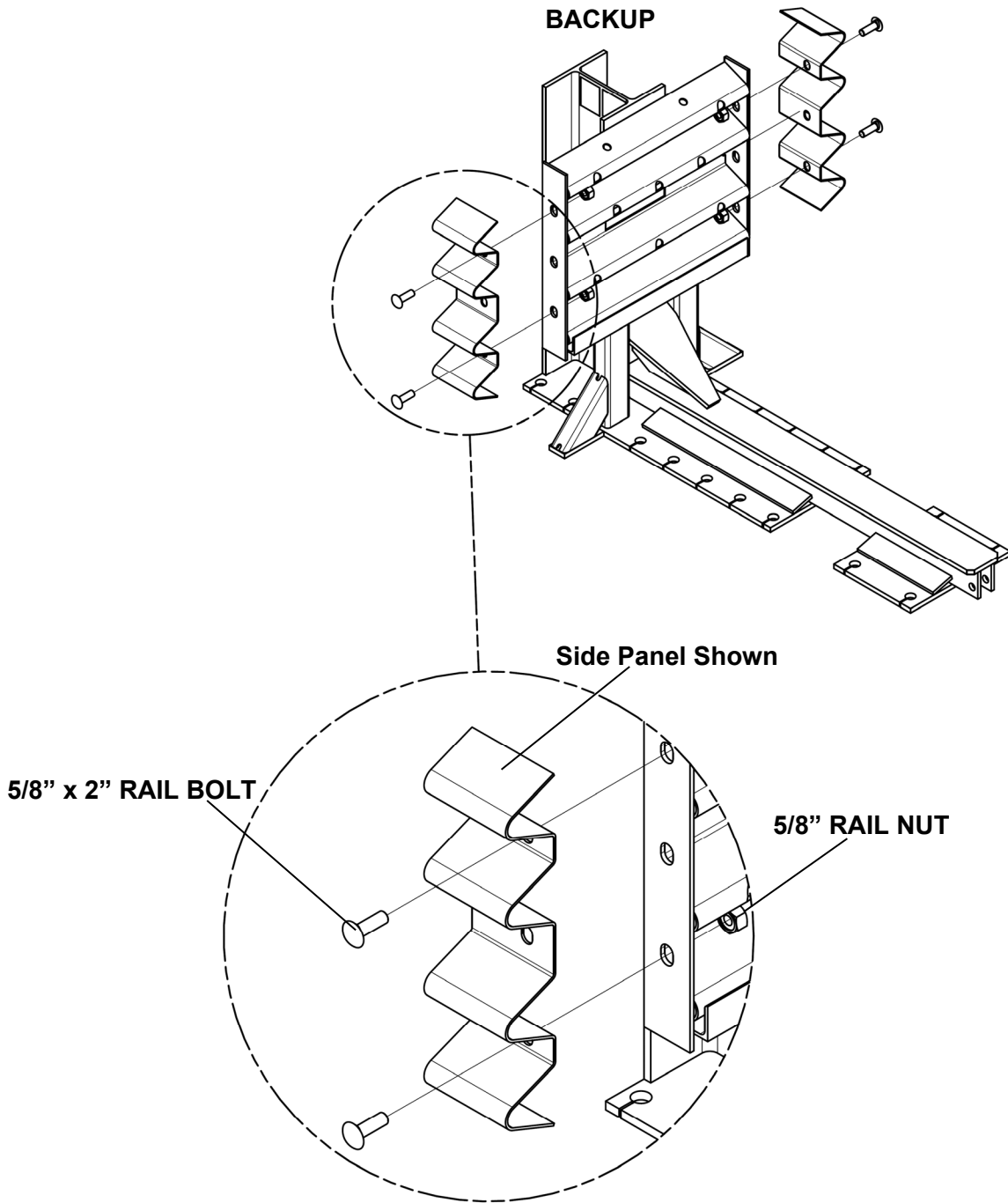


**Figure 20**  
Rail Height and Alignment

#### 4) Attach Side Panels / Transition Panels to Backup Assembly

Attach the Transition Panel or Side Panel as appropriate to each side of the Backup. Refer to Figure 21 and the drawing package for more information.

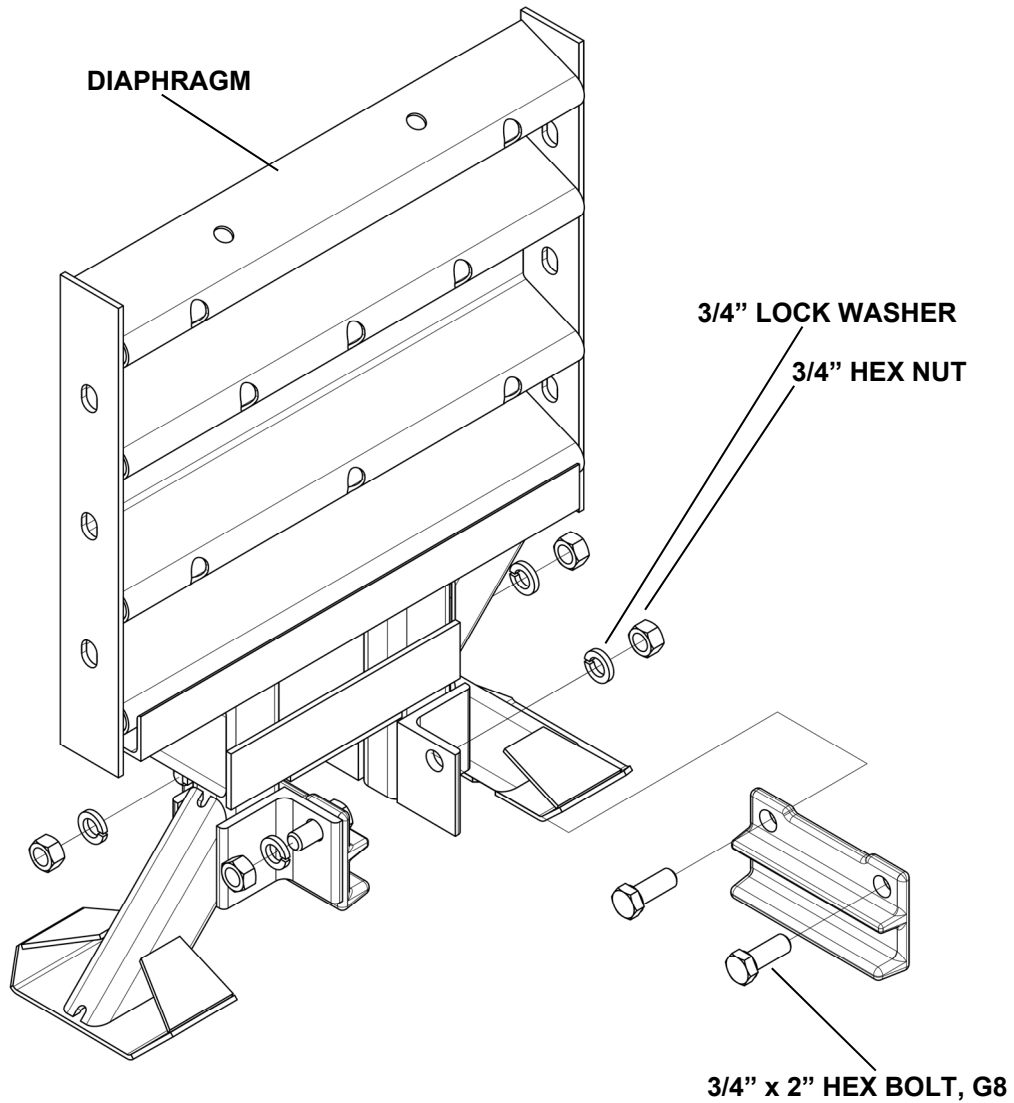
**Note:** A Side Panel is not needed when a Transition Panel is used.



**Figure 21**  
**Side Panel/Transition Panel Attachment**

## 5) Attach Monorail Guides

Attach Monorail Guides to Diaphragms as shown in Figure 22, and the Diaphragm Assembly drawing.

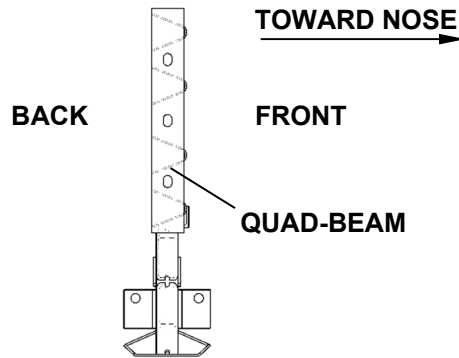


**Figure 22**  
**Monorail Guide Attachment**

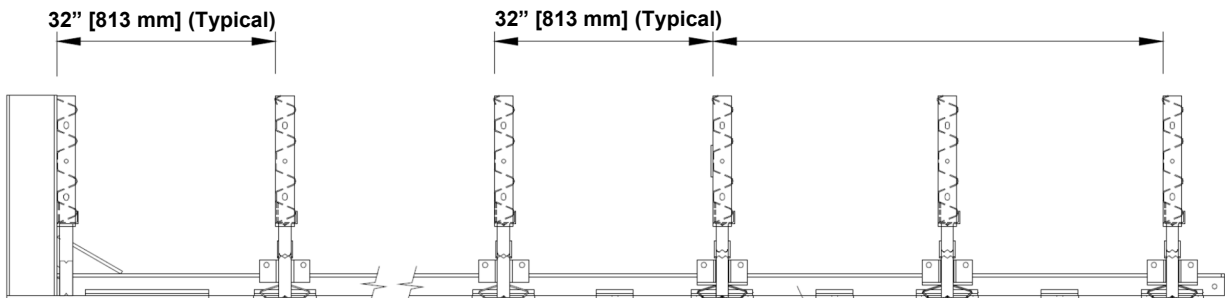


## 6) Deploy Diaphragms

Orient a Diaphragm so that the front face of the Quad-Beam shape faces toward the Nose of the system as shown in Figure 23. Slide one Diaphragm all the way to the Backup to ensure the system is able to collapse properly during impact. Once this has been verified, slide the Diaphragm forward to approximately 32" [813 mm] in front of the Backup. Orient and slide all Diaphragms onto Monorail and position each approximately as shown below (Figure 24).



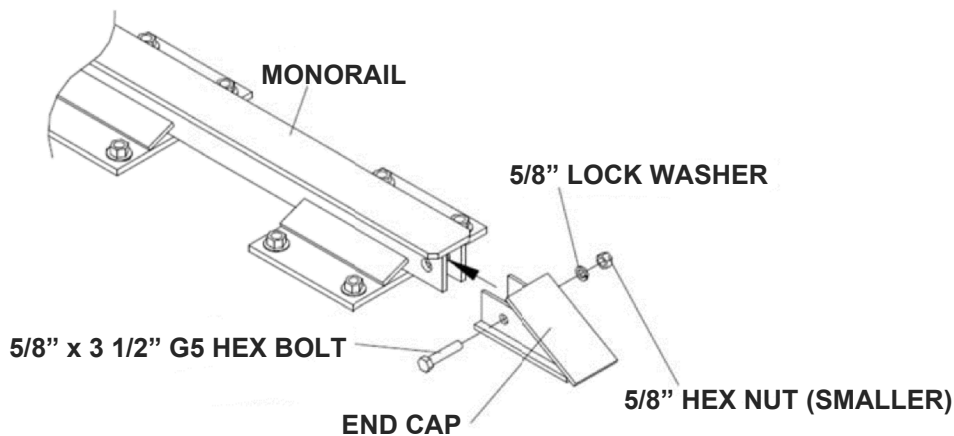
**Figure 23**  
**Diaphragm Orientation**



**Figure 24**  
**Diaphragm spacing**

## 7) Attach End Cap

Attach End Cap to the Monorail as shown in Figure 25 and the Monorail Assembly drawing.



**Figure 25**  
**End Cap Attachment**

## 8) Fender Panel Attachment

Starting at the Backup and working forward, assemble Left and Right Fender Panels as shown in Figure 27.

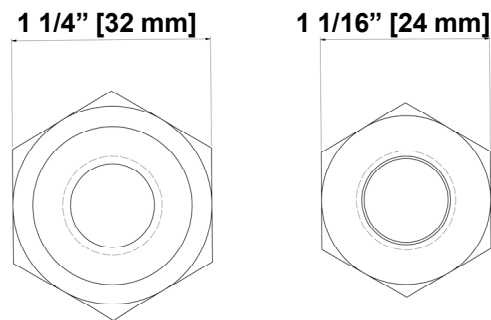
**Step 1.** Place the Fender Panel so that the center hole of the rearward Diaphragm is lined up with the approximate center of the slot in the Fender Panel.

Attach the Mushroom Washer Assembly as shown in Figure 27 but do not tighten at this time. (This helps to balance the Fender Panel.)

**Step 2.** Slide the Fender Panel forward until the holes in the Fender Panel line up with the holes in the forward Diaphragm.

**Step 3.** Use a drift pin to align the center hole of the Fender Panel with the center hole of the Diaphragm.

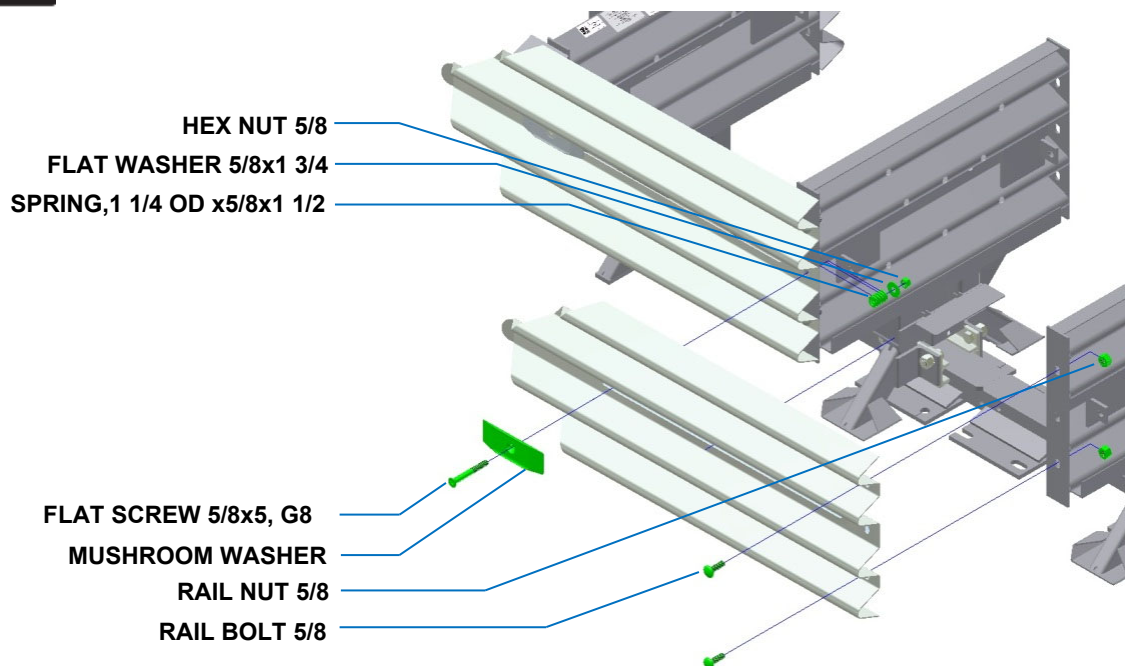
**Step 4.** Attach the front of the Fender Panels to the next Diaphragm using two rail bolts and large hex nuts per side. Use only the top and bottom holes; leave the center hole open until the next Fender Panel is attached.



**Figure 26**

### Rail Nuts are Oversize

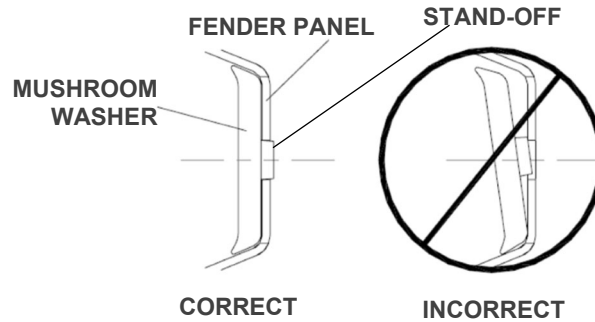
**Important:** Do not mix the 5/8" rail nuts (larger) with the 5/8" heavy hex nuts (smaller) (Figure 26).



**Figure 27**

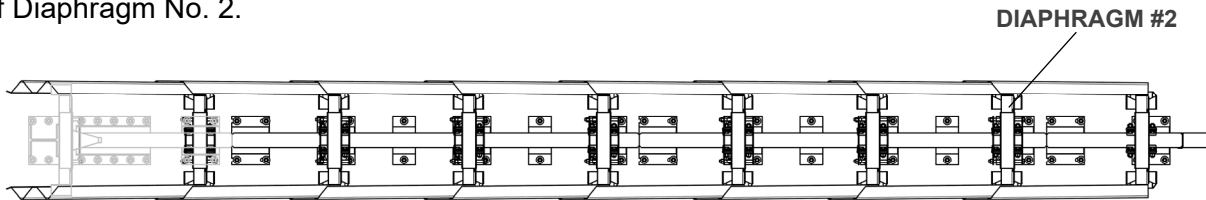
### Fender Panel Assembly

Be sure Mushroom Washers lay flat against the Fender Panel as shown below. Stand-off on Mushroom Washer must be seated completely through slot (Figure 28).



**Figure 28**

Continue attaching Fender Panels until you reach Diaphragm No. 2. Figure 29 shows the location of Diaphragm No. 2.



**Figure 29**  
**Locate Diaphragm No. 2**

### 9) Cylinder Assembly

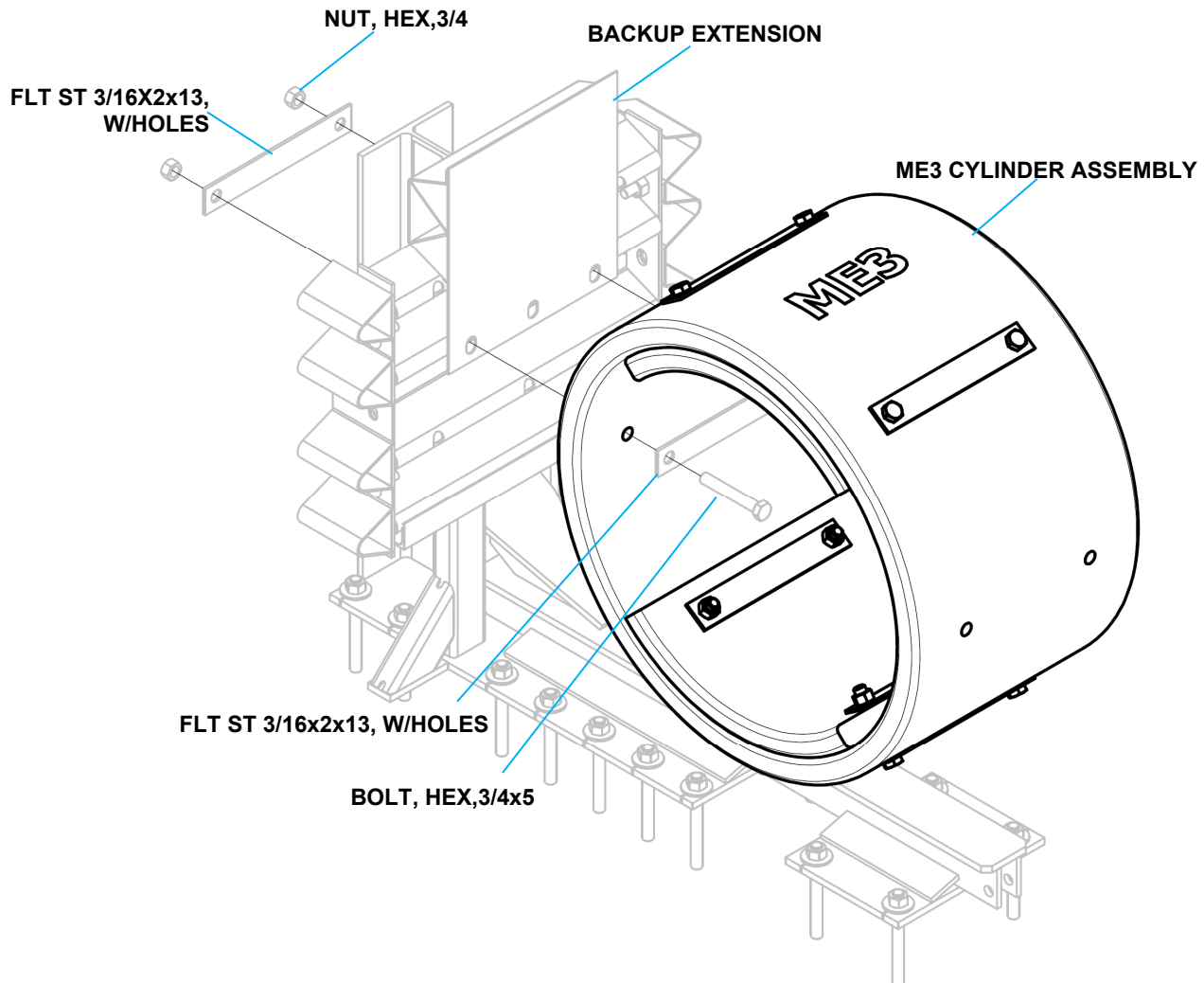
All QuadGuard® Elite M10 systems utilize three Cylinder types. Bay 1 contains a Cylinder with ME1 stenciled on the outer surface. The remaining Bays will contain Cylinders with ME2 or ME3 stenciled on the outer surface. The Nose Assembly contains a single walled 28” outside diameter Cylinder with QEN stenciled on the surface. For specific Cylinder quantities and placement, see reference drawings in back.



**Warning:** Placing the wrong type Cylinder in the nose or any Bay may result in impact performance outside of MASH criteria.

## 10) Attach Rear Most ME3 Cylinder

Beginning at the Backup, place Backup Extension in place, locate and position a ME3 Cylinder such that it is centered to the mounting holes. Fasten to Backup using 3/4"x5" hex bolts, hex nuts, and bar washers. Slide the rear most Diaphragm towards the Cylinder such that no gaps exist between the Backup, Cylinder, and Diaphragm.



**Figure 30**  
**Typical Backup ME3 Cylinder Assembly**

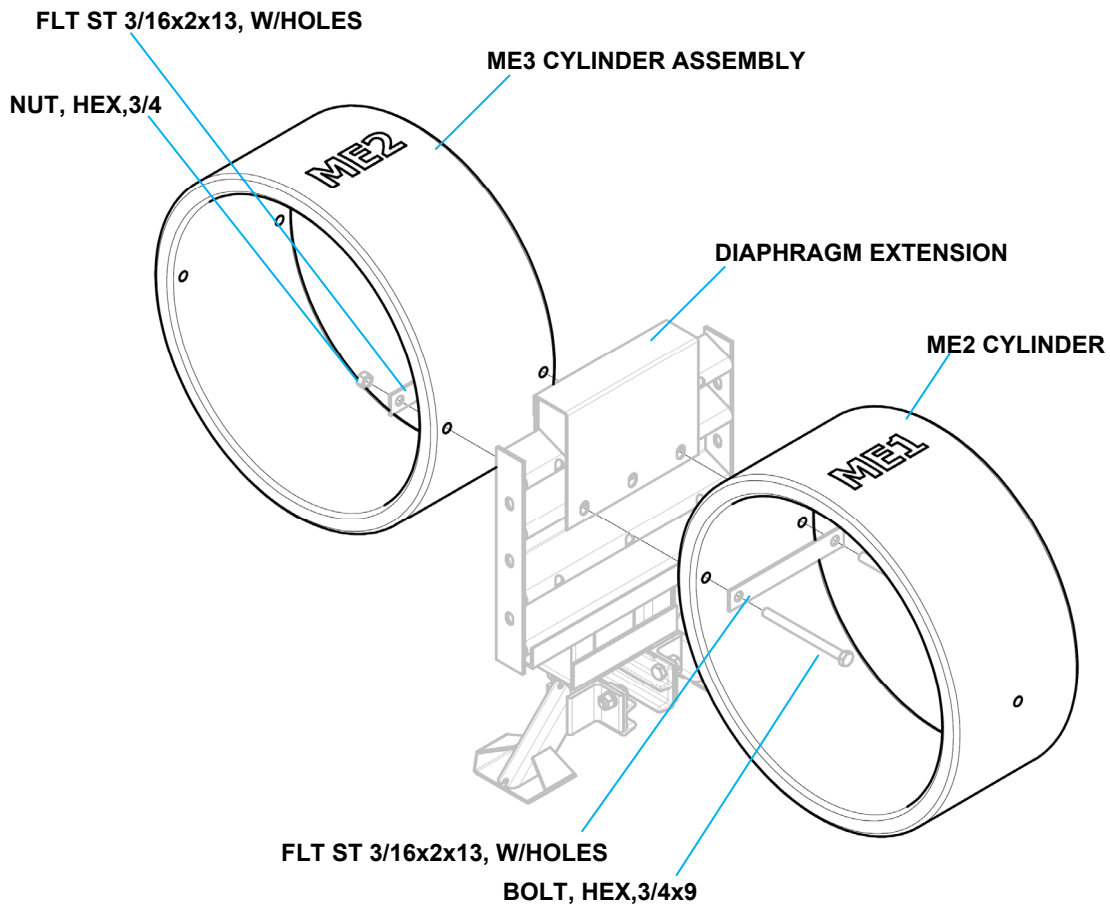
## 11) Attach Remaining ME3 Cylinders

Continue attaching the ME3 Cylinders to their common diaphragms using 3/4"x9" hex bolts. Work forward from the Backup and attach ME3 Cylinders as you proceed forward. Be sure to remove any clearance between the ME3 Cylinders and their adjacent Diaphragms.

## 12) Attach the ME2 & ME1 Cylinders

Attach ME2 Cylinders with Diaphragm Extensions to the appropriate Bays in the same manner used to attach the ME3 Cylinders.

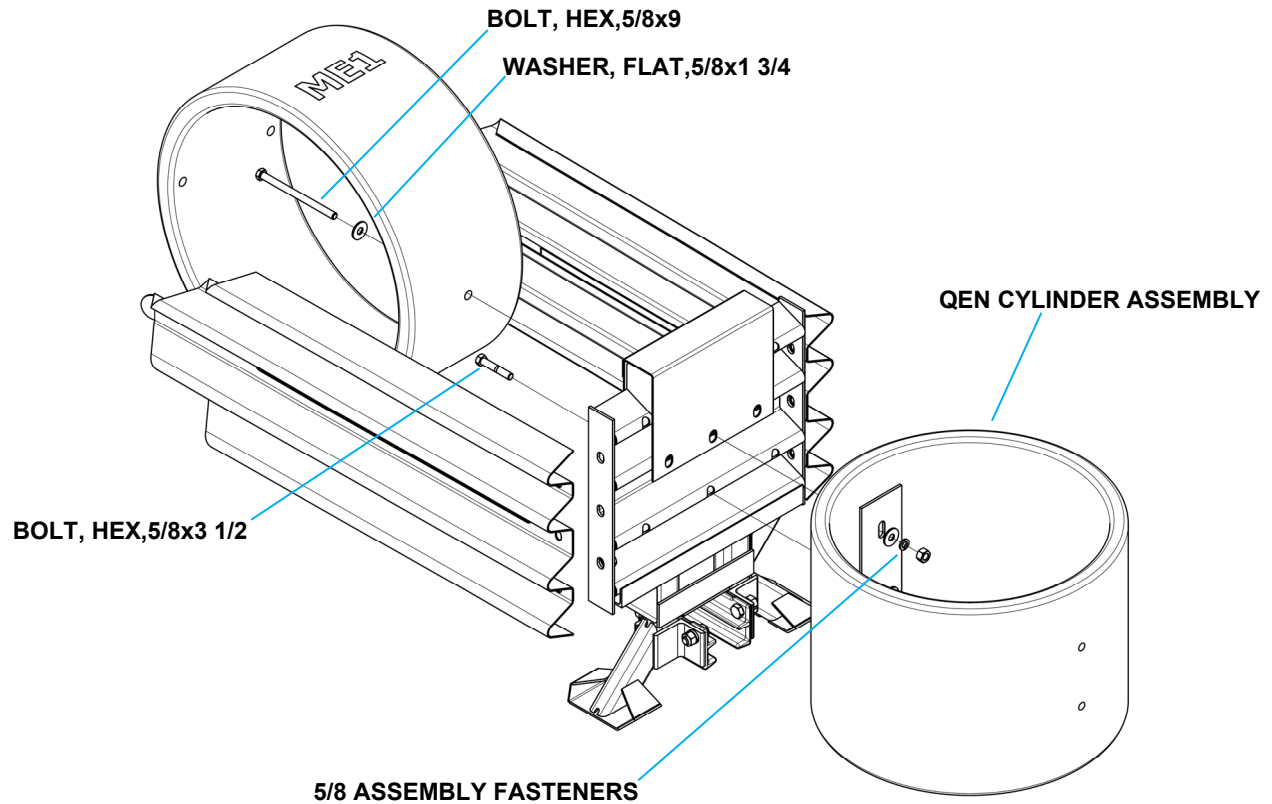
Attach ME1 Cylinder with Diaphragm Extension to Bay 1 in the same manner used to attach the ME2 & ME3 Cylinders.



**Figure 31**  
**Typical ME3 Cylinder Mounting**

### 13) Attach Nose Cylinder

Attach the Nose Cylinder using two 5/8" bolts through the Nose Cylinder Plate, Nose Cylinder, and Diaphragm (Figure 33). Secure each 5/8" hex bolt with flat washers, lock washers, and hex nuts. Torque bolts to 20 ft-lb [27 N-m] minimum, 25 ft-lb [34 N-m] maximum.



**Figure 33**  
**Attach Nose Cylinder to First Diaphragm**

#### 14) Attach Nose Belt

Finally attach the Nose Belt to the Fender Panels using 5/8" x 2" long hex bolts (6), 5/8" flat washers (24) and 5/8" hex nuts (18), through the Belt Clamps (Figure 34).

The Nose of the system may be delineated to comply with local codes (chevron, reflectorized sign, etc.).



**Warning:** Placing the wrong type Cylinder in the Nose or any Bay may result in impact standards outside of MASH criteria.

Adjust the hex nuts so that the faces of the flat washers are flush with the outside humps of the Fender Panels (Figure 34).

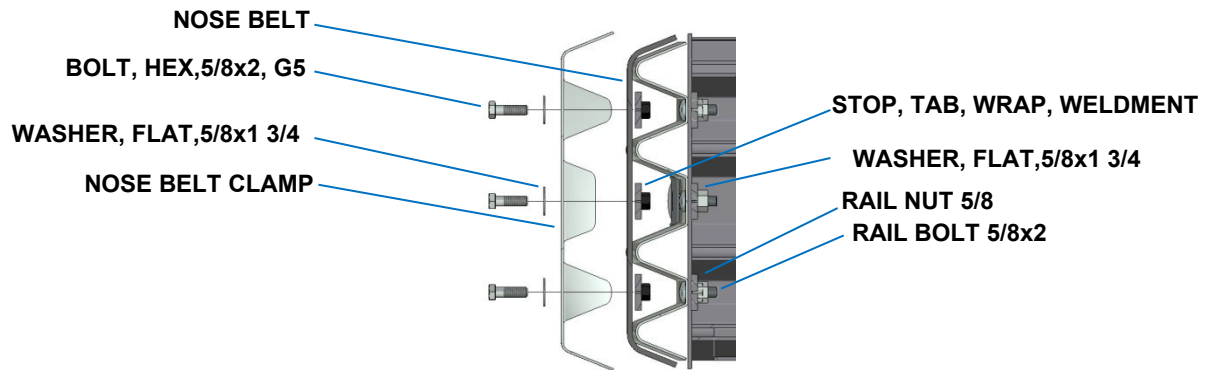


Figure 34

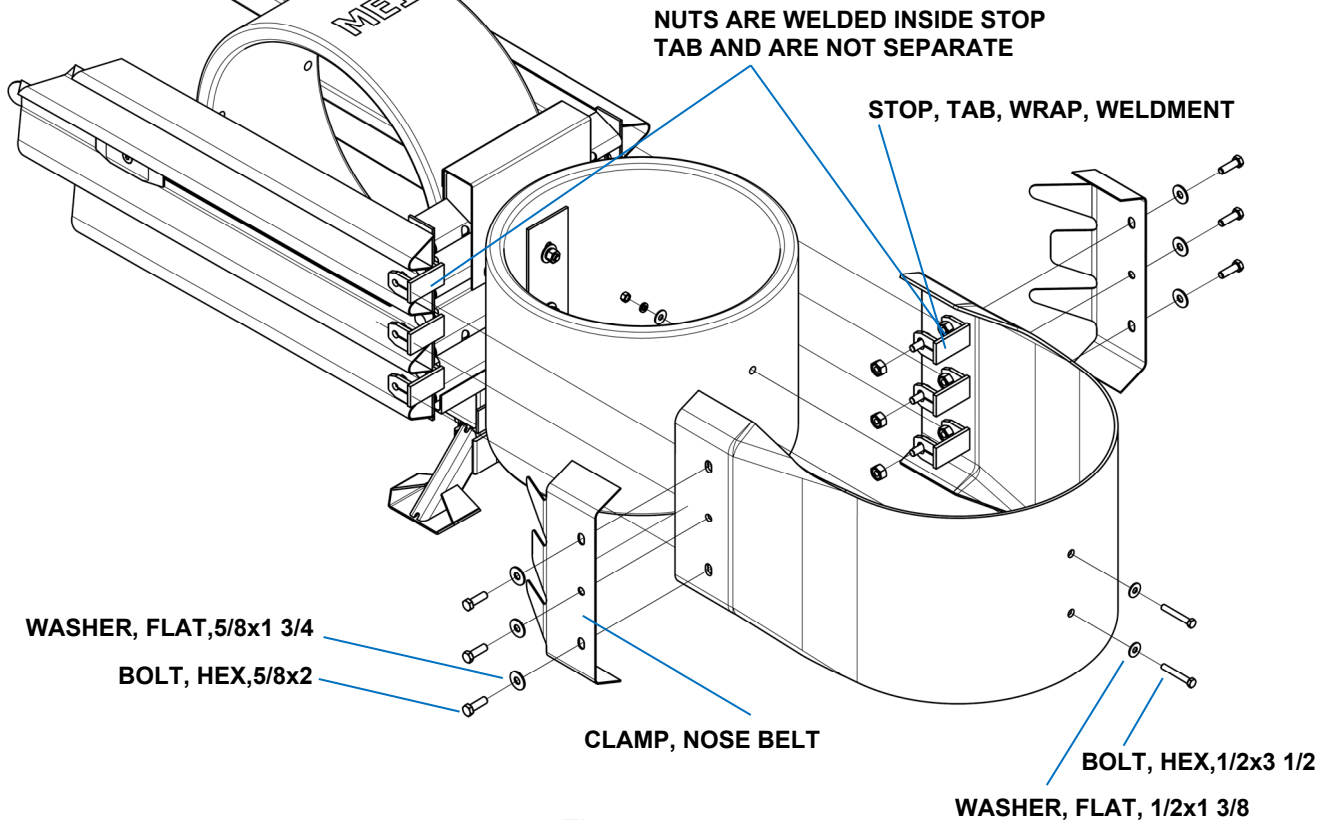


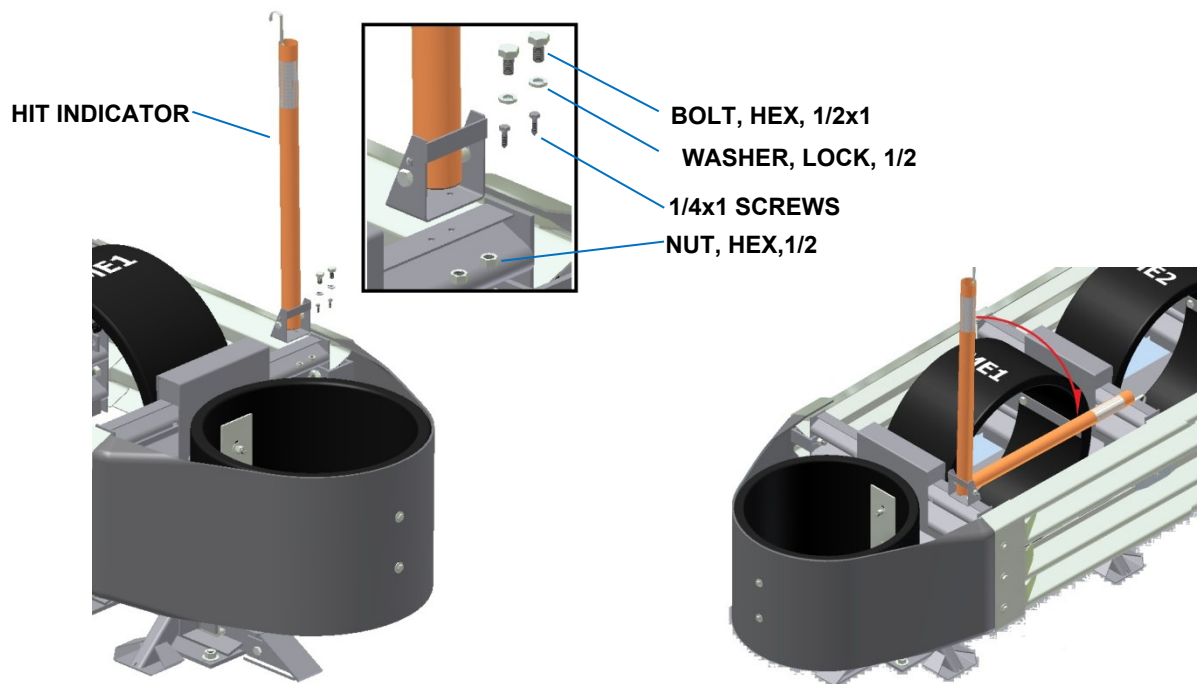
Figure 35

#### Attach Nose Belt to Fender Panels

### 15) Attach Hit Indicator to Diaphragm No. 1

The Hit Indicator should be the last component attached to the system. Fasten the Hit Indicator to the first Diaphragm with the hardware provided as shown in Figure 36. Offset component to right side of Diaphragm.

- Step 1.** Position Hit Indicator on 1<sup>st</sup> Diaphragm. Center Hit Indicator 2 1/2" from edge of Diaphragm for 24" systems. Drill one 1/4" hole as needed to set bracket tab in Diaphragm.
- Step 2.** Attach hit indicator to 1<sup>st</sup> Diaphragm.
  - Option 1.** Match drill two 9/16" holes as needed in Diaphragm. Use 1/2" hex bolts, 1/2" lock washers, and 1/2" hex nuts to attach bracket (p. 14).
  - Option 2.** Use 1/4" self-drilling + tap screws along with flat washer to attach bracket.
- Step 3.** Rotate Hit indicator to horizontal position and bend trigger clip around top of 2<sup>nd</sup> diaphragm (Figure 37).



**Figure 36**  
**Attach Hit Indicator**

**Figure 37**  
**Rotate Hit Indicator/Bend Trigger Clip**

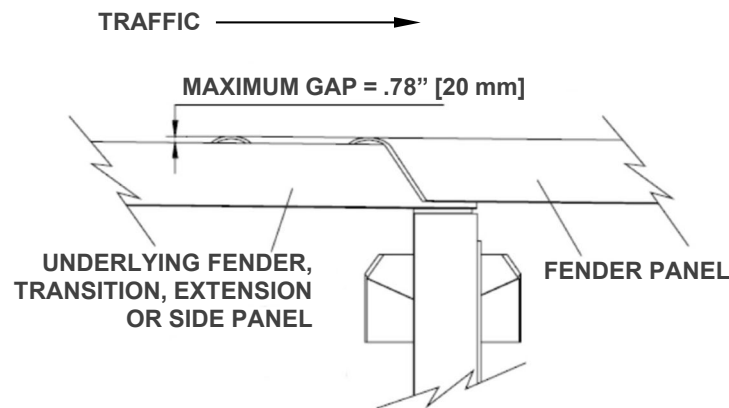


## 16) Checking The System

At this point tighten all Mushroom Bolts and recheck to ensure that all fasteners are properly tightened throughout the system (anchor bolts, etc.). Check all Fender Panels. If they do not fit tightly against the underlying panel, system realignment may be necessary (Figure 38).



Bolt Torque Specifications	
<b>Warning:</b>	
Anchor Studs	Torque to 100 ft-lb Shall Not protrude above nuts (p. 29, Figure 18)
All Other Bolts	Tightened
Fender Panel	Maximum gap allowed: Narrow Systems – 0.78" [20 mm]



**Figure 38**  
**Fender Panel Gap**

## Pre-Assembled System Installation Instructions

The QuadGuard Elite M10 may be ordered pre-assembled. Pre-assembled systems come in two 4-Bay sections. **A forklift or equivalent is required for installation.**

- A. Remove one Monorail Guide from the same side of each Diaphragm of both pre-assembled sections.
- B. Unbolt the rear Cylinder and rear Fender Panels from the Backup.
- C. Lift each 4-Bay section away from the Backup and Monorails.
- D. Place the Backup and Monorails into position and install anchors (pp. 27-29).
- E. Lift the rear section onto the Monorail and against the Backup.
- F. Reconnect rear Cylinder and Fender Panels to Backup (p. 35).
- G. Lift the front section onto the Monorail and push it back until it contacts the front Diaphragm of the rear section.
- H. Reattach ME3/ME2 Cylinders, mushroom washers, and monorail guide assemblies at each diaphragm.

## **QuadGuard® Elite M10 Final Inspection Checklist**

**Site Location:** \_\_\_\_\_

**Date:** \_\_\_\_\_

**Inspector:** \_\_\_\_\_

**Refer to the QuadGuard® Elite M10 Assembly manual and/or drawing package.**

- If no transition is used, narrow side panels are used with Backup (p. 8)
- Proper Transition Panel is used for the type of barrier (pp. 15 - 16)
- Minimum clearance of 25" behind rear Fender Panels for movement (p. 18)
- Anchor nuts are torqued to 100 ft-lb (p. 20)
- Cylinder types are properly placed (p. 23)
- Every borehole and slot in Backup and Monorail is utilized (pp. 28 - 29)
- Anchor stud(s) height is 1 1/2" [38 mm] or less above the pad (p. 29)
- Monorail guides are attached to the Diaphragms (p. 31)
- Monorail End Cap Assembly in place (p. 32)
- Fender Panel nuts are bottomed out on Mushroom Washer bolt (p. 33)
- Mushroom Washers tabs lay flat within Fender Panel slots (pp. 34, 43)
- Each Diaphragm and Backup Extension is attached (pp. 35 - 38)
- Cylinders are bolted together and tight (pp. 35 - 38)
- Bolts and nuts are properly tightened throughout the system (p. 40)
- Fender Panel gap is 0.78" or less for Narrow systems (p. 40)
- Nose Cylinder is level (p. 48)
- System is clear of debris

## Maintenance and Repair



**Important:** Inspections are recommended, as needed, based upon volume of traffic and impact history. Visual Drive-By Inspections are recommended at least once a month. Walk-Up Inspections are recommended at least once a year.

### Visual Drive-By Inspection

- 1) Encountering a system with the Hit Indicator in the vertical position mandates inspection of the system. A walk-up inspection will be necessary.
- 2) Inspect the system in accordance with the QuadGuard® Elite M10 Maintenance Flow Chart (p. 48).



**Caution:** It is important to inspect a system after it has been impacted even if it appears to be self-restored and fully maintained. In particular, check the Fender Panels/Diaphragm attachment bolts to be sure none have failed.

- 3) Be sure the Nose assembly is in place and in good condition.
- 4) Note the location and condition of the QuadGuard® Elite M10 and the date of visual drive-by inspection.

### Walk-Up Inspection



**Warning:** A system that has been impacted can store energy in collapsed Cylinders and may spring back unexpectedly causing possible serious injury. Use caution when inspecting, disassembling or restoring systems that are collapsed or compressed by any amount.

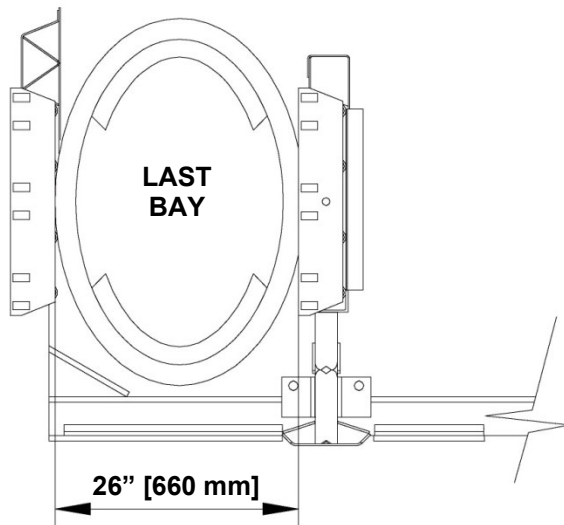
### Maintenance Checklist

- 1) Clear and dispose of any debris on the site. Check along length of Monorail and remove any debris.
- 2) All bolts are tight and rust free.
- 3) Monorail Anchor Nuts are securely anchored.
- 4) Diaphragm Legs are straight.
- 5) All Mushroom Washer Assemblies are properly aligned and positioned (p. 44).
- 6) Fender Panels and Transition Panels should nest tightly against the system. For wrong way traffic, the maximum gap allowed is .78" [20 mm].
- 7) All Cylinders are in good condition and are properly positioned within each Bay.
- 8) Always inspect system if the Hit Indicator is in the UP position even if the system appears normal.
- 9) Reset Hit Indicator after inspection and restoration of the QuadGuard® Elite M10.

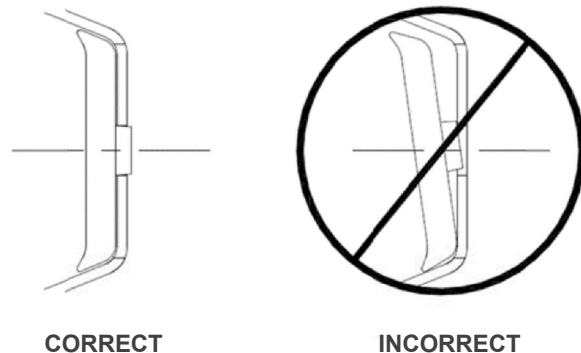


**Important:** The energy absorbing HDPE Cylinders lose their ability to absorb energy with increasing number of system impacts. After multiple full capacity design impacts, the system will no longer be able to meet the requirements as specified in MASH. To ensure that Cylinder replacement is accomplished before this condition occurs, it is essential that this part of the inspection be conducted every time the Hit Indicator indicates the system has been impacted.

The rear-most Cylinder must measure at least 26" [660 mm] for proper impact performance (Figure 39). If distance is less than 26" [660 mm], replace all ME1 and ME2 Cylinders. If distance is greater than 26" [660 mm], inspect all Cylinders for major cracks, tears or cuts. Replace any damaged Cylinders. Please call the Valtir Customer Service Department if you have any questions (p. 3).



**Figure 39**  
**Distance Across**  
**Minor Axis of ME2 Cylinder**



**Figure 40**  
**Mushroom Washer Orientation**

10) Ensure the system is deployed to its full length.



**Caution:** Systems that are not restored to their full length may not perform to impact performance standards of MASH.

- 11) Make all necessary repairs as described above and see the following page for Post-Impact Instructions.
- 12) Reset Hit Indicator if necessary.
- 13) Note the location and condition of the QuadGuard® Elite M10, and any work done, in your **Impact Attenuator Inspection Logbook** under the date of this inspection. If further repair is required, note repair request date in logbook. Walk-up inspections are recommended as needed based upon volume of traffic and impact history. Refer to Post-Impact Instructions on the next page for more information.

## Post-Impact Instructions

- 1) Deploy the appropriate traffic-control devices to protect your crew.



**Warning:** An impacted system can store energy in collapsed Cylinders and **may spring back unexpectedly** causing serious injury. Use caution during post-impact inspections for repair or refurbishment.



**Warning:** It is the responsibility of the worker to keep hands and other body parts clear of system interaction. Be aware of tools (pry bar, etc.) that could move unexpectedly if a bind is suddenly released.

- 2) Position a minimum 1-ton pickup truck on the system just in front of the Nose Assembly. Place the truck bumper against the system. The truck bumper height, approximately 24" [610 mm], should rest against the middle center of the Nose Assembly.



**Warning:** Once the bumper is over the system's Monorail, the vehicle may be subject to pushing force due to unexpected restoration. The driver should be wearing a seat belt and have the vehicle in the lowest possible gear when approaching the system. In the event the system unexpectedly deploys before Step 2 is complete, the driver should apply the brakes immediately to bring the vehicle to a controlled stop. The vehicle must be in neutral while still applying the brakes and then gradually release the brakes to allow the system to restore against the truck bumper in a safe and controlled way.

- 3) Once the truck is in place, carefully move the truck so the bumper displaces the Nose Cylinder 6". In the absence of the Nose assembly, place protective material between the bumper and the first Diaphragm leaving a 1.00" gap between the protective material and the truck bumper. It is the responsibility of the driver to remain in the vehicle to apply the brake during initial system displacement.



**Caution:** Use a pry bar with a 1-ton truck to release additional mechanical binds in a safe and controlled manner.

- 4) Wrap a chain, 3/8"X20' Grade 40 minimum, around the first Diaphragm (Figure 42). Attach both ends of chain to truck bumper anchor points.



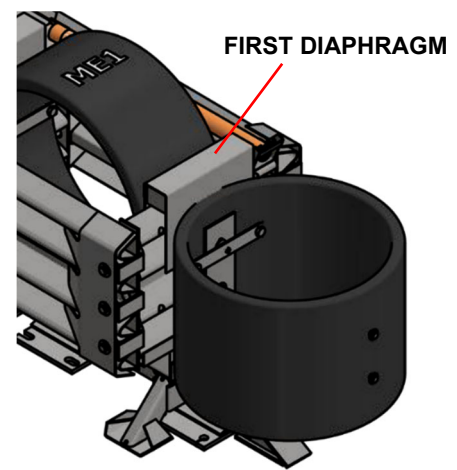
**Important:** Wrap chain around the first Diaphragm so the pull force is aligned with the long slots in the Fender Panels to ensure a smoother extension.



**Warning:** Stand clear in case chain breaks or becomes disconnected.



**Important:** Have someone watch during repositioning to ensure undetected damage does not cause the Diaphragms to bind or pull out improperly. Wait ten minutes after full extension for Cylinders to regain their former shape.



**Figure 41**  
**Attach Chain to First Diaphragm**

- 5) Ensure the Mushroom Washer Assemblies holding the Fender Panels together are still intact and the system has not been deformed to prevent it from pulling back fully to its original position.



**Caution:** Use eye protection and gloves when repairing any Mushroom Washer Die Spring Assembly. Do not place fingers underneath an assembled Mushroom Washer. Parts may suddenly shift and fingers may be pinched. If the Die Spring is still under compression, then secure it with a clamp to ensure safe action and release when the nut is removed.

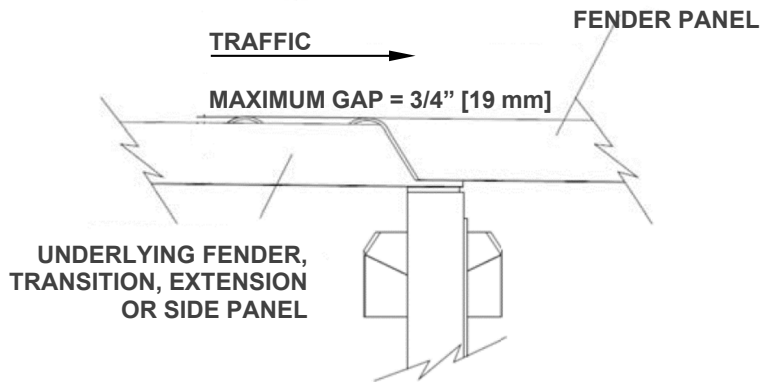
- 6) The system should now be safe to approach for debris removal and further mechanical binding inspection. Binding is typically located at the Monorail Guides near the front Diaphragms or Fender Panels.
- 7) Verify all Anchor Bolts are firmly anchored to the roadway surface. Replace any loose, broken, or pulled out Anchors. Proper performance of the system depends on the Monorail Anchors being properly deployed.
- 8) All Diaphragm Support Legs must be properly attached to the Monorail.
- 9) Inspect the system in accordance with the QuadGuard® Elite M10 Maintenance Flow chart (p. 47). The Cylinders are potentially reusable after typical design speed impacts. See the Limitations and Warnings section on page 5.
- 10) Diaphragms that are bowed or have bent legs must be replaced.
- 11) Each Fender Panel must be properly attached with a Mushroom Washer Assembly. Check all Fender Panel to Diaphragm bolt connections. All damaged bolts, Fender Panels and Transition Panels must be replaced.
- 12) The maximum gap allowed for overlapping Fender Panels on the side of the system with traffic approaching from the rear (including Fender Panels overlapping components behind the system) is 3/4" [19 mm]. Mushroom Washer Assembly nuts must be tightened to the bolt shank. Replace damaged parts if a gap between any Fender Panel exceeds 3/4" [19 mm] (p. 46).
- 13) Replace all damaged Cylinders. If a Cylinder's condition is questionable, a photo of the Cylinder may be forwarded to Valtir for evaluation (p. 3).
- 14) Tighten and torque all fasteners on the system (p. 46).
- 15) Clear site debris.
- 16) The QuadGuard® Elite M10 is ready for use.



**Important:** Because every impact is different, Valtir makes no recommendation whether use or reuse of any part of the system is appropriate or acceptable following an impact. It is the sole responsibility of the project engineer and/or the local highway authority and its engineers to make that determination. It is critical that you inspect this product after assembly is complete to make certain that the instructions provided in this manual have been strictly followed



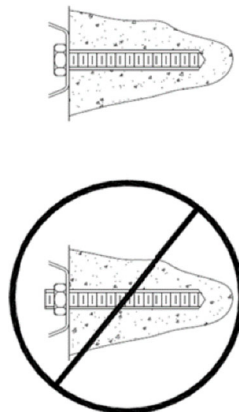
**CAUTION:**



**Figure 42**  
**Fender Panel Gap**



<b>Torque Specifications</b>	
<b>Warning:</b>	
Mushroom Bolt Assemblies	Tighten to end of bolt threads
Anchor Studs	Torque to 100 ft-lb and shall NOT protrude 1 1/2" above nuts (Figure 18 on p. 29)
All Other Bolts	Tightened
Fender Panel 24" System	Maximum Gap Allowed 3/4" [19 mm]



**Figure 43**  
**Horizontal Assembly**

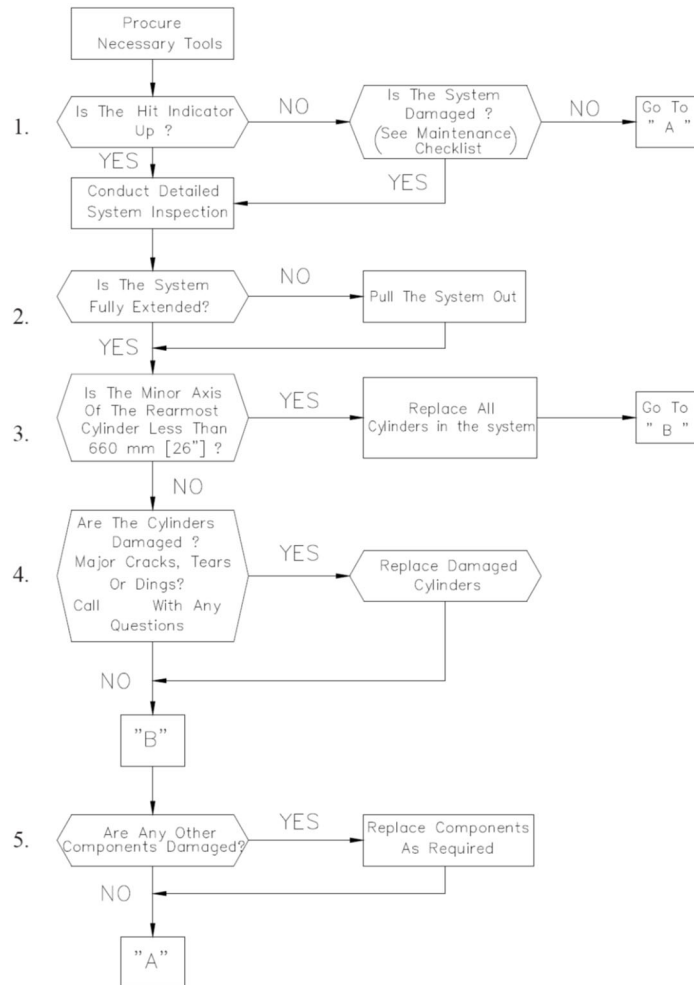
## Parts Ordering Procedure

Make a list of all damaged parts using part descriptions illustrated on drawings in the back. Answer the following questions in the spaces provided. This information is necessary to receive the proper parts.

QuadGuard® Elite M10 Ordering Information Chart		
Description:	Choices	Fill in this section
Transition Panel Type Right side, left side, or no Transition (p. 15)	Thrie Beam / End Shoe Extended End Shoe 4" Offset Safety Shape 6" Offset Single Slope 31" W-Beam	
Width of Backup	24" [610 mm]	

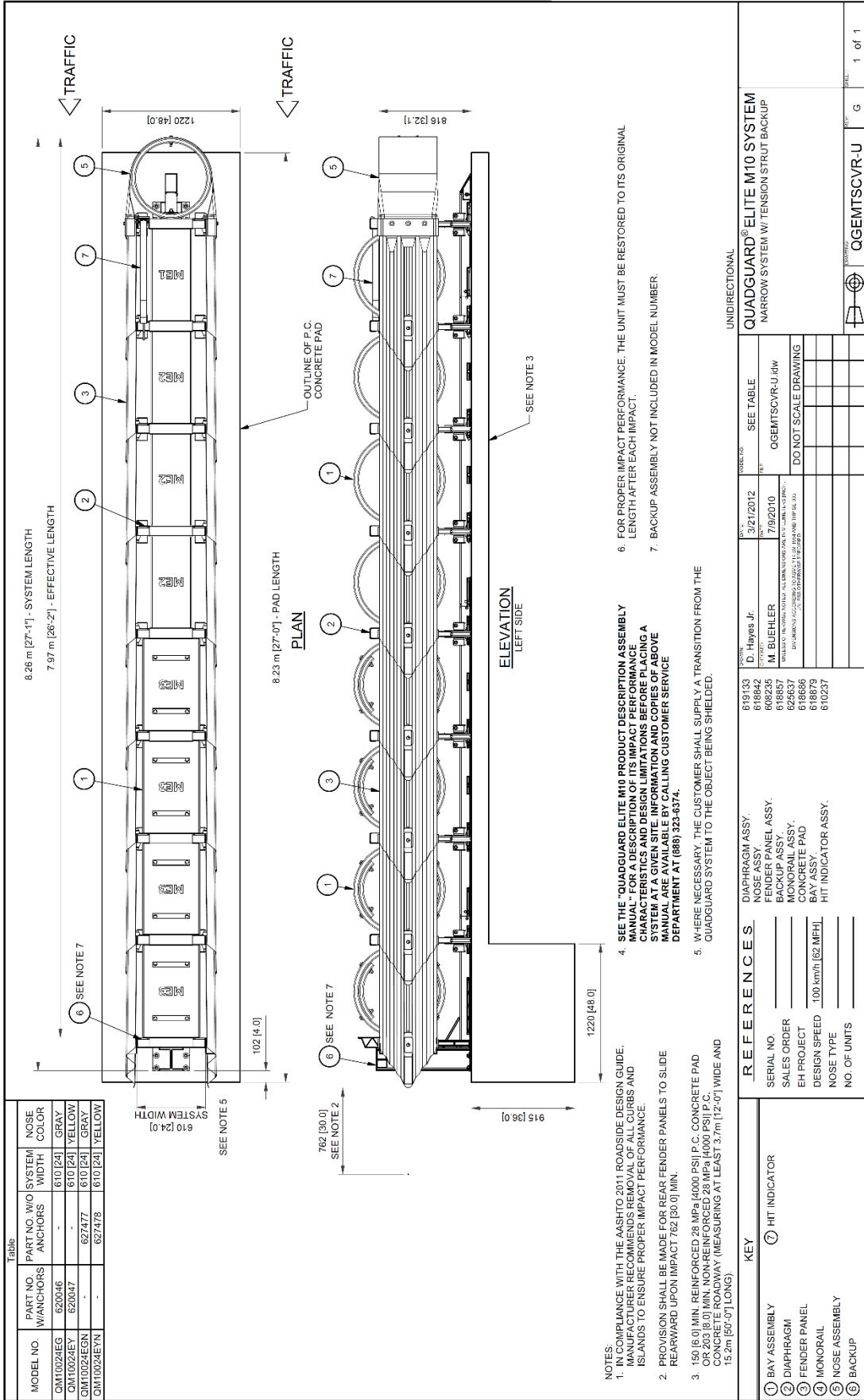
## Maintenance Flow Chart

This flow chart is provided only to clarify the sequence of steps. Refer to the appropriate sections of this manual for specific procedures. Step 5 represents final inspection of system components and QuadGuard® Elite M10 restoration (pp. 41-46).





# Drawings



MODEL NO.	PART NO. W/ ANCHORS	PART NO. W/O ANCHORS	SYSTEM WIDTH	NOSE COLOR
CMT0024EG	620046	-	610 [24]	GRAY
CMT0024EY	620047	-	610 [24]	YELLOW
CMT0024EGN	627477	-	610 [24]	GRAY
CMT0024EYN	627478	-	610 [24]	YELLOW

KEY	REFERENCES
① BAY ASSEMBLY	DIAPHRAGM ASSY.
② DIAPHRAGM	NOSE ASSY.
③ FENDER PANEL	FENDER PANEL ASSY.
④ MONORAIL	MONORAIL ASSY.
⑤ NOSE ASSEMBLY	CONCRETE PAD
⑥ BACKUP	BAY ASSY.
	HIT INDICATOR ASSY.

- NOTES:**
- IN COMPLIANCE WITH THE AASHTO 2011 ROADSIDE DESIGN GUIDE, MANUFACTURER RECOMMENDS REMOVAL OF ALL CURBS AND ISLANDS TO ENSURE PROPER IMPACT PERFORMANCE.
  - PROVISION SHALL BE MADE FOR REAR FENDER PANELS TO SLIDE REARWARD UPON IMPACT 762 [30.0] MIN.
  - 150 [6.0] MIN. REINFORCED 28 MPa [4000 PSI] P.C. CONCRETE PAD OR 202 [8.0] MIN. NON-REINFORCED 28 MPa [4000 PSI] P.C. CONCRETE PAD (MEASURING AT LEAST 3.7m [12.4'] WIDE AND 19.2m [62.9'] LONG).
  - SEE THE "QUADGUARD ELITE M10 PRODUCT DESCRIPTION ASSEMBLY MANUAL" FOR A DESCRIPTION OF ITS IMPACT PERFORMANCE CHARACTERISTICS AND DESIGN LIMITATIONS BEFORE PLACING A SYSTEM AT A GIVEN SITE. INFORMATION AND COPIES OF ABOVE DEPARTMENT AT (888) 323-6374.
  - WHERE NECESSARY, THE CUSTOMER SHALL SUPPLY A TRANSITION FROM THE QUADGUARD SYSTEM TO THE OBJECT BEING SHIELDED.
  - FOR PROPER IMPACT PERFORMANCE, THE UNIT MUST BE RESTORED TO ITS ORIGINAL LENGTH AFTER EACH IMPACT.
  - BACKUP ASSEMBLY NOT INCLUDED IN MODEL NUMBER.

REV.	DATE	BY	CHKD.	DESCRIPTION
1	3/21/2012	D. Hayes Jr.		ISSUE TO
2	7/9/2010	M. BUEHLER		REVISED TO INCLUDE TENSION STRUT BACKUP

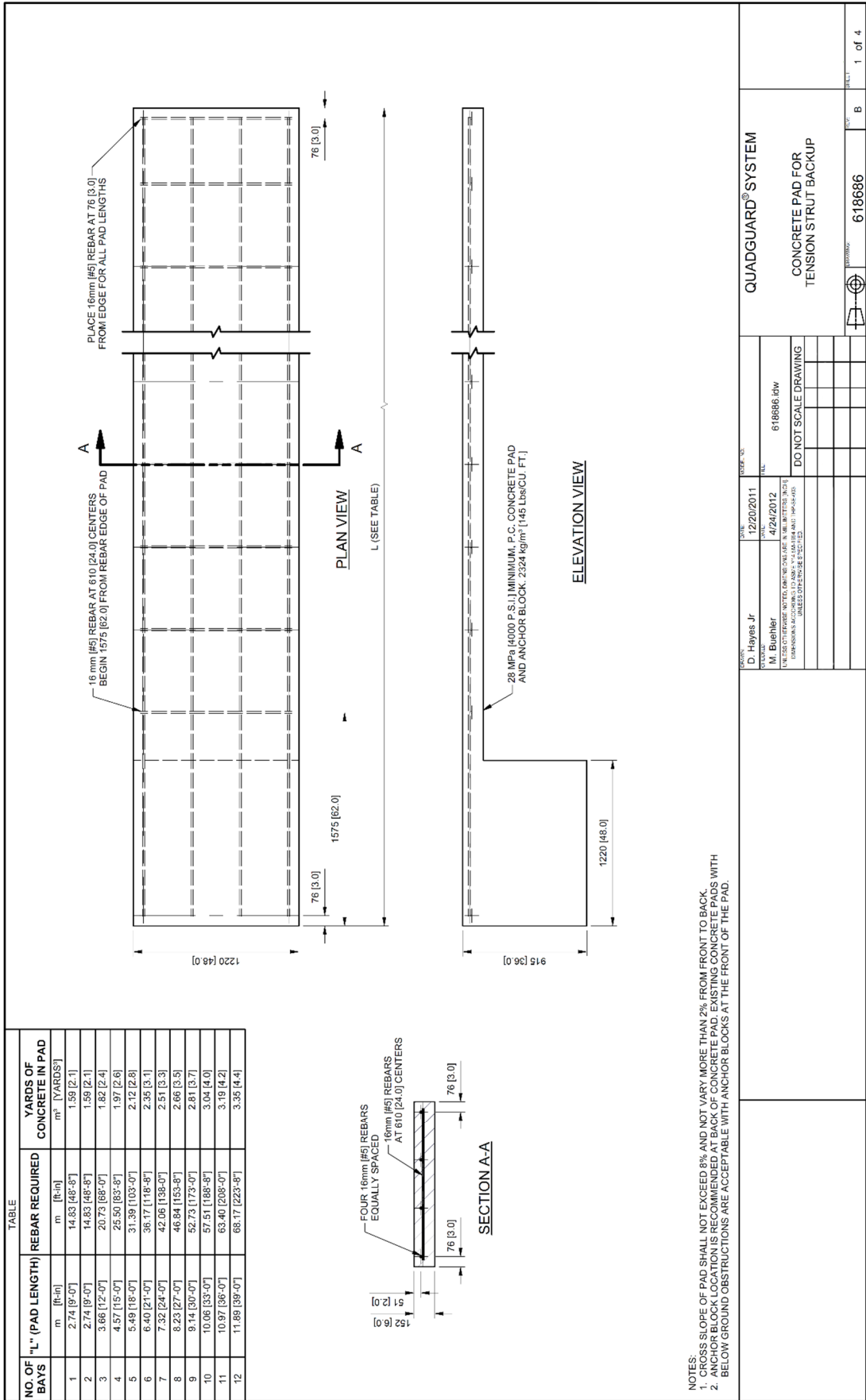
UNIDIRECTIONAL

MODEL NO.	SEE TABLE
REV.	QGEMTSCVR-U HW
DO NOT SCALE DRAWING	

QUADGUARD® ELITE M10 SYSTEM  
NARROW SYSTEM W/ TENSION STRUT BACKUP

NO.	1	OF	1
DATE			

## QuadGuard® Elite M10 QGEMTSCVR-U

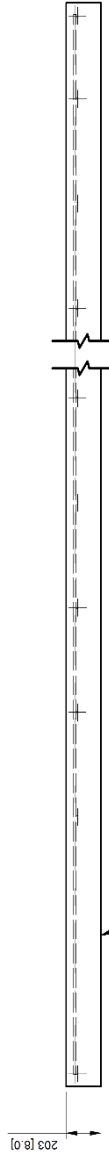
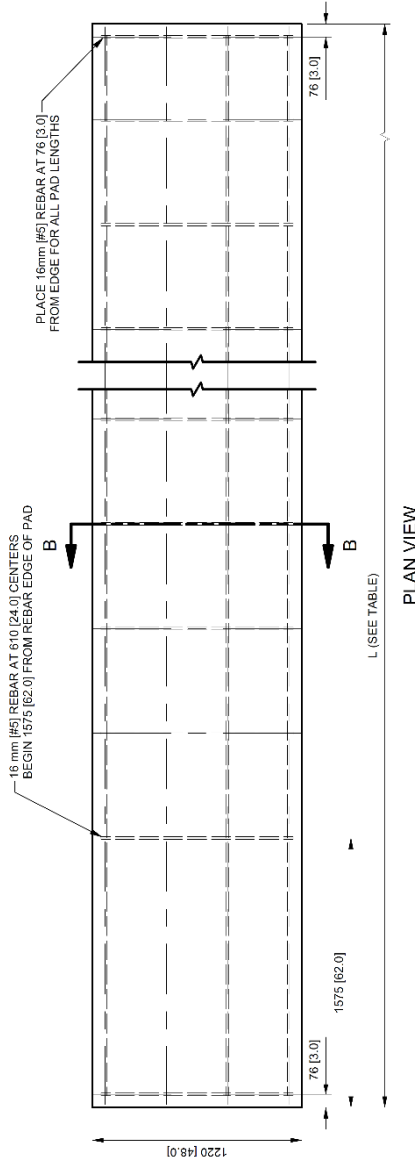
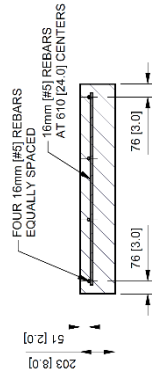


NOTES:  
 1. GROSS SLOPE OF PAD SHALL NOT EXCEED 8% AND NOT VARY MORE THAN 2% FROM FRONT TO BACK.  
 2. ANCHOR BLOCK LOCATION IS RECOMMENDED AT BACK OF CONCRETE PAD. EXISTING CONCRETE PADS WITH BELOW GROUND OBSTRUCTIONS ARE ACCEPTABLE WITH ANCHOR BLOCKS AT THE FRONT OF THE PAD.

**TS Concrete Pad 618686**

TABLE

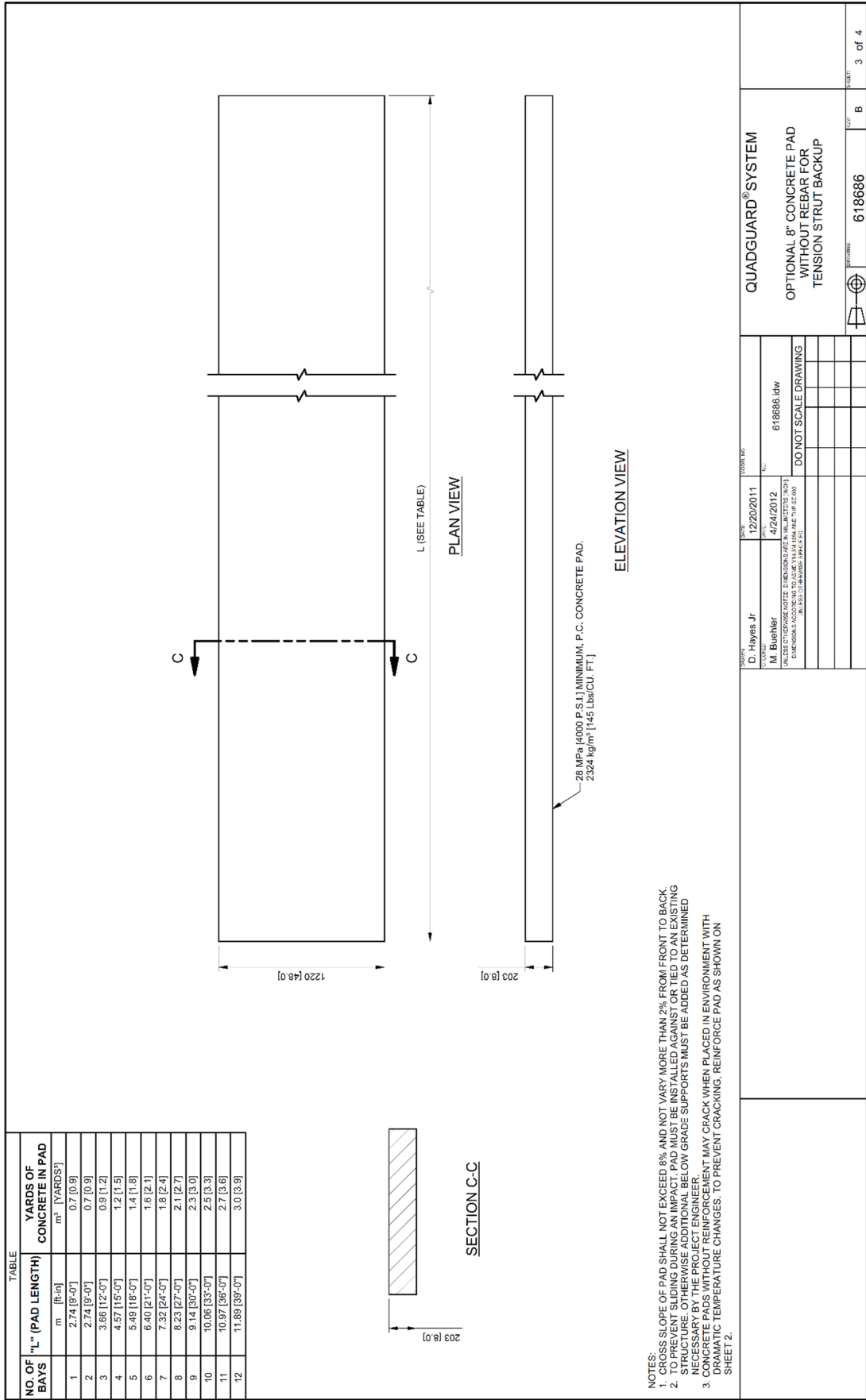
NO. OF BAYS	"L" (PAD LENGTH)	REBAR REQUIRED	YARDS OF CONCRETE IN PAD
	m [ft-in]	m [ft-in]	m <sup>3</sup> [YARDS <sup>3</sup> ]
1	2.74 [9'-0"]	14.83 [48'-8"]	0.7 [0.9]
2	2.74 [9'-0"]	14.83 [48'-8"]	0.7 [0.9]
3	3.66 [12'-0"]	20.73 [68'-0"]	0.9 [1.2]
4	4.57 [15'-0"]	25.50 [83'-8"]	1.2 [1.5]
5	5.49 [18'-0"]	31.39 [103'-0"]	1.4 [1.8]
6	6.40 [21'-0"]	36.17 [118'-8"]	1.6 [2.1]
7	7.32 [24'-0"]	42.06 [138'-0"]	1.8 [2.4]
8	8.23 [27'-0"]	46.84 [153'-8"]	2.1 [2.7]
9	9.14 [30'-0"]	52.73 [173'-0"]	2.3 [3.0]
10	10.06 [33'-0"]	57.51 [188'-8"]	2.5 [3.3]
11	10.97 [36'-0"]	63.40 [208'-0"]	2.7 [3.6]
12	11.89 [39'-0"]	68.17 [223'-8"]	3.0 [3.9]



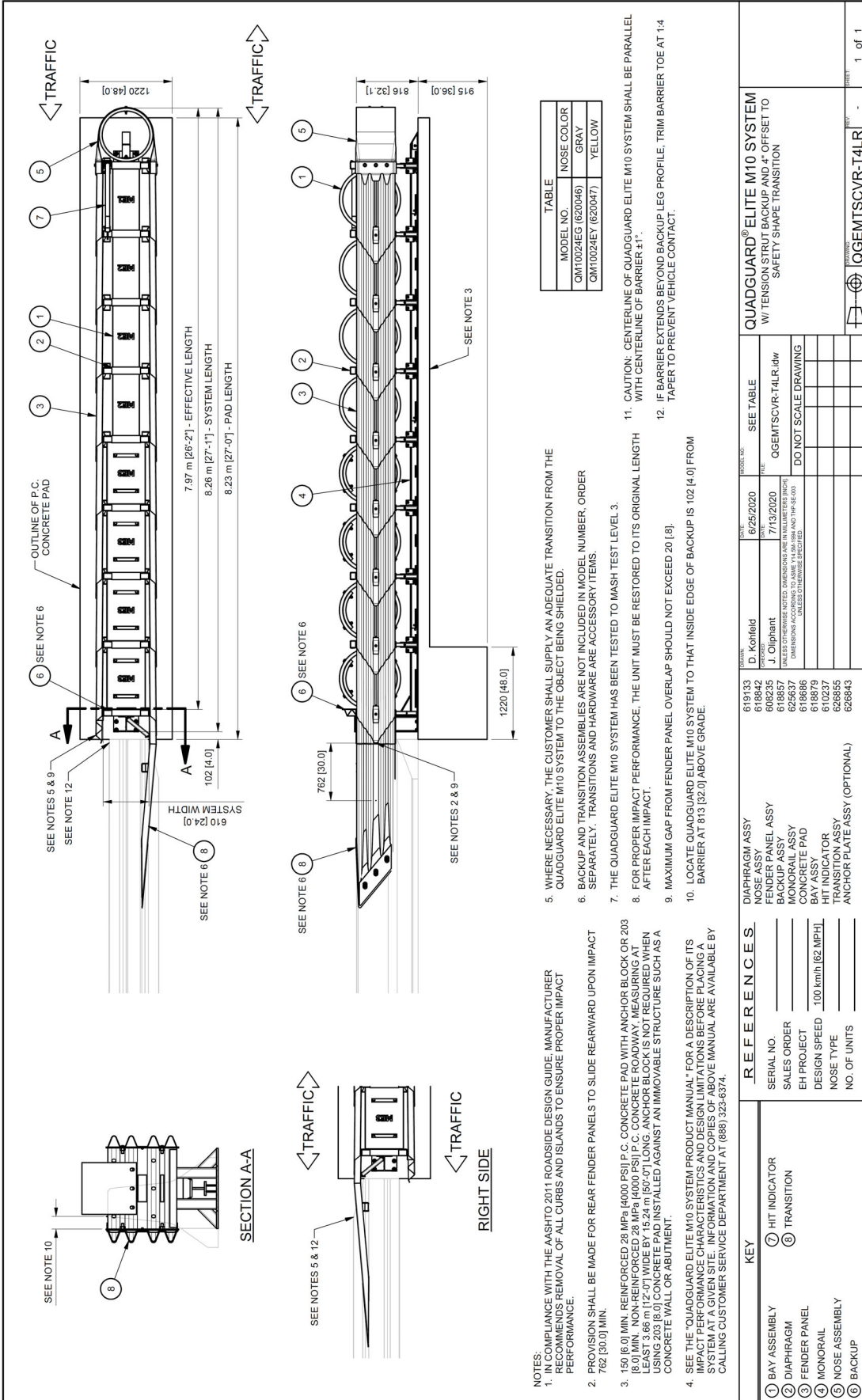
- NOTES:
- CROSS SLOPE OF PAD SHALL NOT EXCEED 8% AND NOT VARY MORE THAN 2% FROM FRONT TO BACK
  - TO PREVENT SLIDING DURING AN IMPACT, PAD MUST BE INSTALLED AGAINST OR TIED TO AN EXISTING STRUCTURE. OTHERWISE ADDITIONAL BELOW GRADE SUPPORTS MUST BE ADDED AS DETERMINED NECESSARY BY THE PROJECT ENGINEER.

QUADGUARD <sup>®</sup> SYSTEM OPTIONAL 8" CONCRETE PAD WITH REBAR FOR TENSION STRUT BACKUP		PROJECT NO. 618686.dwg DATE 12/20/2011 DRAWN BY M. Buehler CHECKED BY M. Buehler APPROVED BY M. Buehler	SHEET NO. 2 of 4 TOTAL SHEETS 4
PROJECT NO. 618686.dwg DATE 12/20/2011 DRAWN BY M. Buehler CHECKED BY M. Buehler APPROVED BY M. Buehler		PROJECT NO. 618686.dwg DATE 12/20/2011 DRAWN BY M. Buehler CHECKED BY M. Buehler APPROVED BY M. Buehler	SHEET NO. 2 of 4 TOTAL SHEETS 4

TS Concrete Pad 8" w/Rebar 618686



**TS Concrete Pad 8" wo/Rebar 618686**



TRAFFIC

TRAFFIC

TRAFFIC

TRAFFIC

RIGHT SIDE

SEE NOTE 10

SEE NOTES 5 & 9  
SEE NOTE 12

SEE NOTE 6

OUTLINE OF P.C. CONCRETE PAD

7.97 m [26'-2"] - EFFECTIVE LENGTH

8.26 m [27'-1"] - SYSTEM LENGTH

8.23 m [27'-0"] - PAD LENGTH

610 [24.0] SYSTEM WIDTH

102 [4.0]

SEE NOTE 6

762 [30.0]

SEE NOTE 6

SEE NOTES 2 & 9

1220 [48.0]

SEE NOTE 3

916 [36.1]

- NOTES:
- IN COMPLIANCE WITH THE AASHTO 2011 ROADSIDE DESIGN GUIDE, MANUFACTURER RECOMMENDS REMOVAL OF ALL CURBS AND ISLANDS TO ENSURE PROPER IMPACT PERFORMANCE.
  - PROVISION SHALL BE MADE FOR REAR FENDER PANELS TO SLIDE REARWARD UPON IMPACT 762 [30.0] MIN.
  - 150 [6.0] MIN. REINFORCED 28 MPa [4000 PSI] P.C. CONCRETE PAD WITH ANCHOR BLOCK OR 203 [8.0] MIN., NON-REINFORCED 28 MPa [4000 PSI] P.C. CONCRETE ROADWAY, MEASURING AT LEAST 3.66 m [12'-0"] WIDE BY 15.24 m [50'-0"] LONG. ANCHOR BLOCK IS NOT REQUIRED WHEN USING 203 [8.0] CONCRETE PAD INSTALLED AGAINST AN IMMOVABLE STRUCTURE SUCH AS A CONCRETE WALL OR ABUTMENT.
  - SEE THE "QUADGUARD ELITE M10 SYSTEM PRODUCT MANUAL" FOR A DESCRIPTION OF ITS IMPACT PERFORMANCE CHARACTERISTICS AND DESIGN LIMITATIONS BEFORE PLACING A SYSTEM AT A GIVEN SITE. INFORMATION AND COPIES OF ABOVE MANUAL ARE AVAILABLE BY CALLING CUSTOMER SERVICE DEPARTMENT AT (888) 323-6374.
  - WHERE NECESSARY, THE CUSTOMER SHALL SUPPLY AN ADEQUATE TRANSITION FROM THE QUADGUARD ELITE M10 SYSTEM TO THE OBJECT BEING SHIELDED.
  - BACKUP AND TRANSITION ASSEMBLIES ARE NOT INCLUDED IN MODEL NUMBER, ORDER SEPARATELY. TRANSITIONS AND HARDWARE ARE ACCESSORY ITEMS.
  - THE QUADGUARD ELITE M10 SYSTEM HAS BEEN TESTED TO MASH TEST LEVEL 3.
  - FOR PROPER IMPACT PERFORMANCE, THE UNIT MUST BE RESTORED TO ITS ORIGINAL LENGTH AFTER EACH IMPACT.
  - MAXIMUM GAP FROM FENDER PANEL OVERLAP SHOULD NOT EXCEED 20 [.8].
  - LOCATE QUADGUARD ELITE M10 SYSTEM TO THAT INSIDE EDGE OF BACKUP IS 102 [4.0] FROM BARRIER AT 813 [32.0] ABOVE GRADE.

TABLE	
MODEL NO.	NOSE COLOR
QM10024EG (620046)	GRAY
QM10024EY (620047)	YELLOW

- CAUTION - CENTERLINE OF QUADGUARD ELITE M10 SYSTEM SHALL BE PARALLEL WITH CENTERLINE OF BARRIER ±1".
- IF BARRIER EXTENDS BEYOND BACKUP LEG PROFILE, TRIM BARRIER TOE AT 1:4 TAPER TO PREVENT VEHICLE CONTACT.

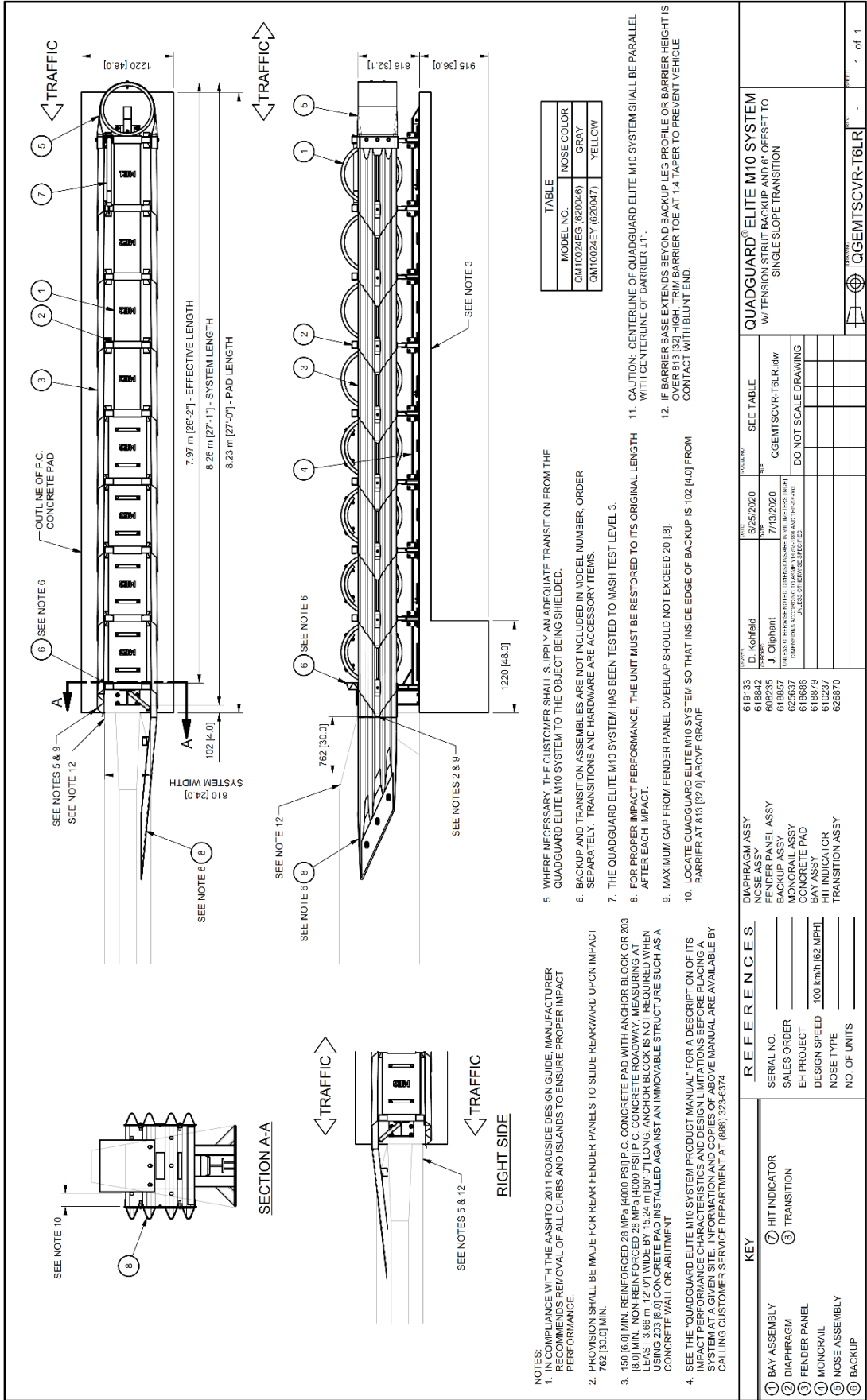
KEY	REFERENCES
① BAY ASSEMBLY	DIAPHRAGM ASSY
② DIAPHRAGM	NOSE ASSY
③ FENDER PANEL	FENDER PANEL ASSY
④ MONORAIL	BACKUP ASSY
⑤ NOSE ASSEMBLY	MONORAIL ASSY
⑥ BACKUP	CONCRETE PAD
⑦ HIT INDICATOR	BAY ASSY
⑧ TRANSITION	HIT INDICATOR
	TRANSITION ASSY
	ANCHOR PLATE ASSY (OPTIONAL)

MODEL NO.	REV	DATE	ISSUE	SEE TABLE
619133	D	6/25/2020	D. Kohfeld	SEE TABLE
618842	J	7/13/2020	J. O'Flaherty	OGEMTSCVR-T4LR.dwg

SERIAL NO.	SALES ORDER	EH PROJECT	DESIGN SPEED	NOSE TYPE	NO. OF UNITS
618857			100 km/h [62 MPH]		
626886					
618879					
610237					
626855					
626843					

QUADGUARD® ELITE M10 SYSTEM	
W/ TENSION STRUT BACKUP AND 4" OFFSET TO SAFETY SHAPE TRANSITION	
DO NOT SCALE DRAWING	
DRAWING NO. QGEMTSCVR-T4LR	
REV. 1 of 1	

4'' Offset Safety Shape Transition QGEMTSCVR-T4LR



6" Offset Single Slope Transition QGEMTSCVR-T6LR

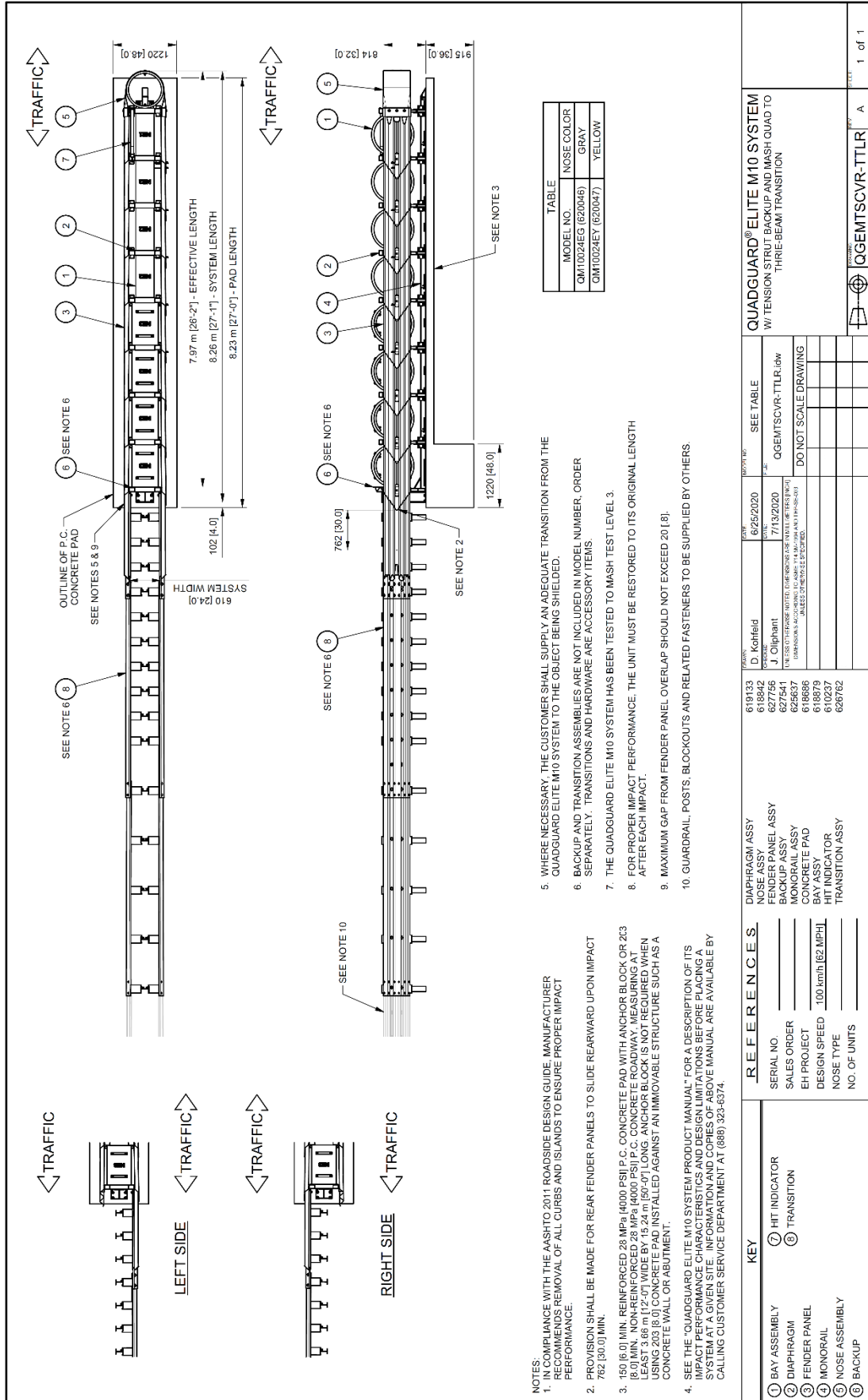


TABLE	
MODEL NO.	NOSE COLOR
QM1022EG (620948)	GRAY
QM10024EY (620047)	YELLOW

- WHERE NECESSARY, THE CUSTOMER SHALL SUPPLY AN ADEQUATE TRANSITION FROM THE QUADGUARD ELITE M10 SYSTEM TO THE OBJECT BEING SHIELDED.
- BACKUP AND TRANSITION ASSEMBLIES ARE NOT INCLUDED IN MODEL NUMBER. ORDER SEPARATELY. TRANSITIONS AND HARDWARE ARE ACCESSORY ITEMS.
- THE QUADGUARD ELITE M10 SYSTEM HAS BEEN TESTED TO MASH TEST LEVEL 3.
- FOR PROPER IMPACT PERFORMANCE, THE UNIT MUST BE RESTORED TO ITS ORIGINAL LENGTH AFTER EACH IMPACT.
- MAXIMUM GAP FROM FENDER PANEL OVERLAP SHOULD NOT EXCEED 20 [8].
- GUARDRAIL, POSTS, BLOCKOUTS AND RELATED FASTENERS TO BE SUPPLIED BY OTHERS.

KEY	REFERENCES
① BAY ASSEMBLY	
② DIAPHRAGM	
③ FENDER PANEL	
④ MONORAIL	
⑤ NOSE ASSEMBLY	
⑥ BACKUP	
⑦ HIT INDICATOR	
⑧ TRANSITION	

KEY	REFERENCES
① BAY ASSEMBLY	
② DIAPHRAGM	
③ FENDER PANEL	
④ MONORAIL	
⑤ NOSE ASSEMBLY	
⑥ BACKUP	
⑦ HIT INDICATOR	
⑧ TRANSITION	

REF. NO.	DESCRIPTION	DATE	BY
619133	D. Kohfeld	6/25/2020	
618942	J. Olyphant	7/13/2020	
627549			
624637			
616686			
618879			
610237			
626762			

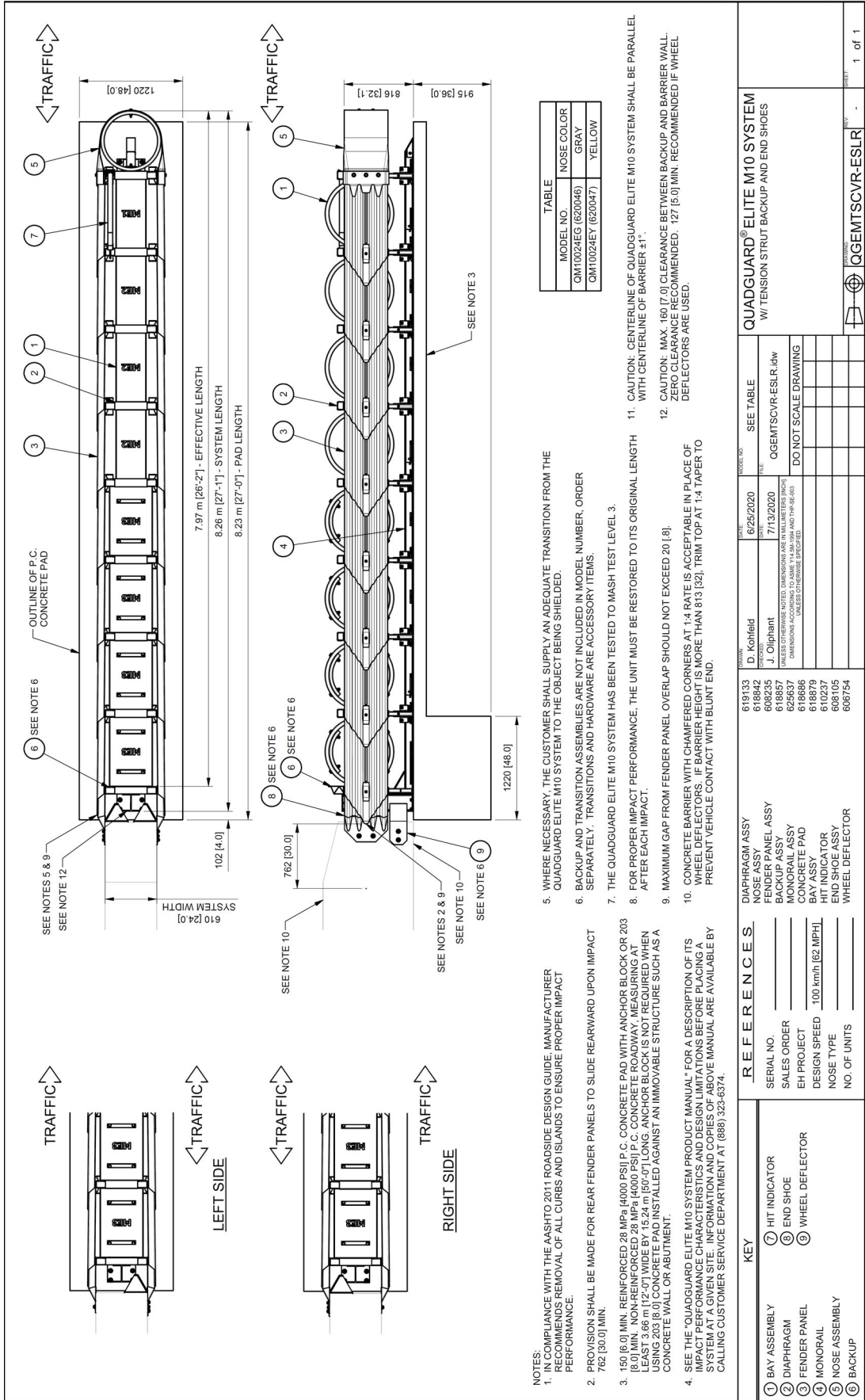
DATE	BY	DESCRIPTION
6/25/2020	D. Kohfeld	ISSUE FOR REVIEW
7/13/2020	J. Olyphant	ISSUE FOR REVIEW

DATE	BY	DESCRIPTION
6/25/2020	D. Kohfeld	ISSUE FOR REVIEW
7/13/2020	J. Olyphant	ISSUE FOR REVIEW

# Thrie-Beam Transition

## QGEMTSCVR-TTLR

1 of 1



**End Shoe Transition** **QGEMTSCVR-ESLR**

KEY		REFERENCES	
①	BAY ASSEMBLY	DIAPHRAGM ASSY	619133
②	FENDER PANEL	FENDER PANEL ASSY	618922
③	WHEEL DEFLECTOR	BACKUP ASSY	618857
④	MONORAIL	MONORAIL ASSY	626637
⑤	NOSE ASSEMBLY	CONCRETE PAD	618686
⑥	BACKUP	BAY ASSY	618879
		HIT INDICATOR	610237
		END SHOE ASSY	608105
		WHEEL DEFLECTOR	606754

DATE	BY	DESCRIPTION
6/25/2020	D. Kohfeld	ISSUED FOR CONSTRUCTION
7/13/2020	J. Cliphart	ISSUED FOR CONSTRUCTION

MODEL NO.	DATE	DESCRIPTION
QGEMTSCVR-ESLR	7/13/2020	ISSUED FOR CONSTRUCTION

TABLE	DESCRIPTION
①	HIT INDICATOR
②	END SHOE
③	WHEEL DEFLECTOR

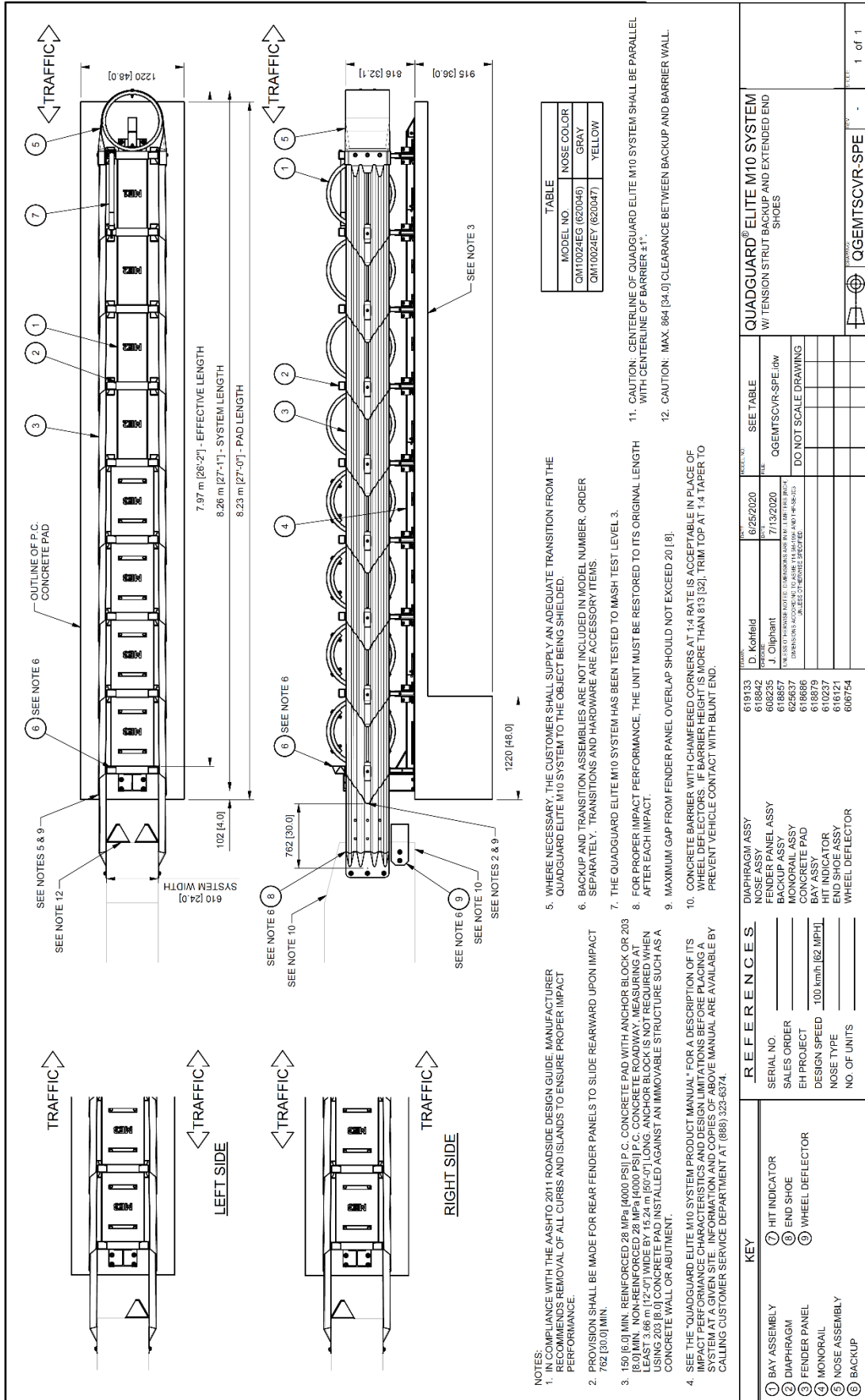
  

TABLE	DESCRIPTION
①	HIT INDICATOR
②	END SHOE
③	WHEEL DEFLECTOR

TABLE	DESCRIPTION
①	HIT INDICATOR
②	END SHOE
③	WHEEL DEFLECTOR





Extended End Shoe Transition QGEMTSCVR-SPE

1 of 1

TABLE	
MODEL NO.	NOSE COLOR
QM10024ECS (620046)	GRAY
QM10024EY (620047)	YELLOW

REFERENCES	
SERIAL NO.	DESCRIPTION
①	BAY ASSEMBLY
②	DIAPHRAGM
③	FENDER PANEL
④	MONORAIL
⑤	NOSE ASSEMBLY
⑥	BACKUP
⑦	HIT INDICATOR
⑧	END SHOE
⑨	WHEEL DEFLECTOR

REFERENCES	
SERIAL NO.	DESCRIPTION
①	BAY ASSEMBLY
②	DIAPHRAGM
③	FENDER PANEL
④	MONORAIL
⑤	NOSE ASSEMBLY
⑥	BACKUP
⑦	HIT INDICATOR
⑧	END SHOE
⑨	WHEEL DEFLECTOR

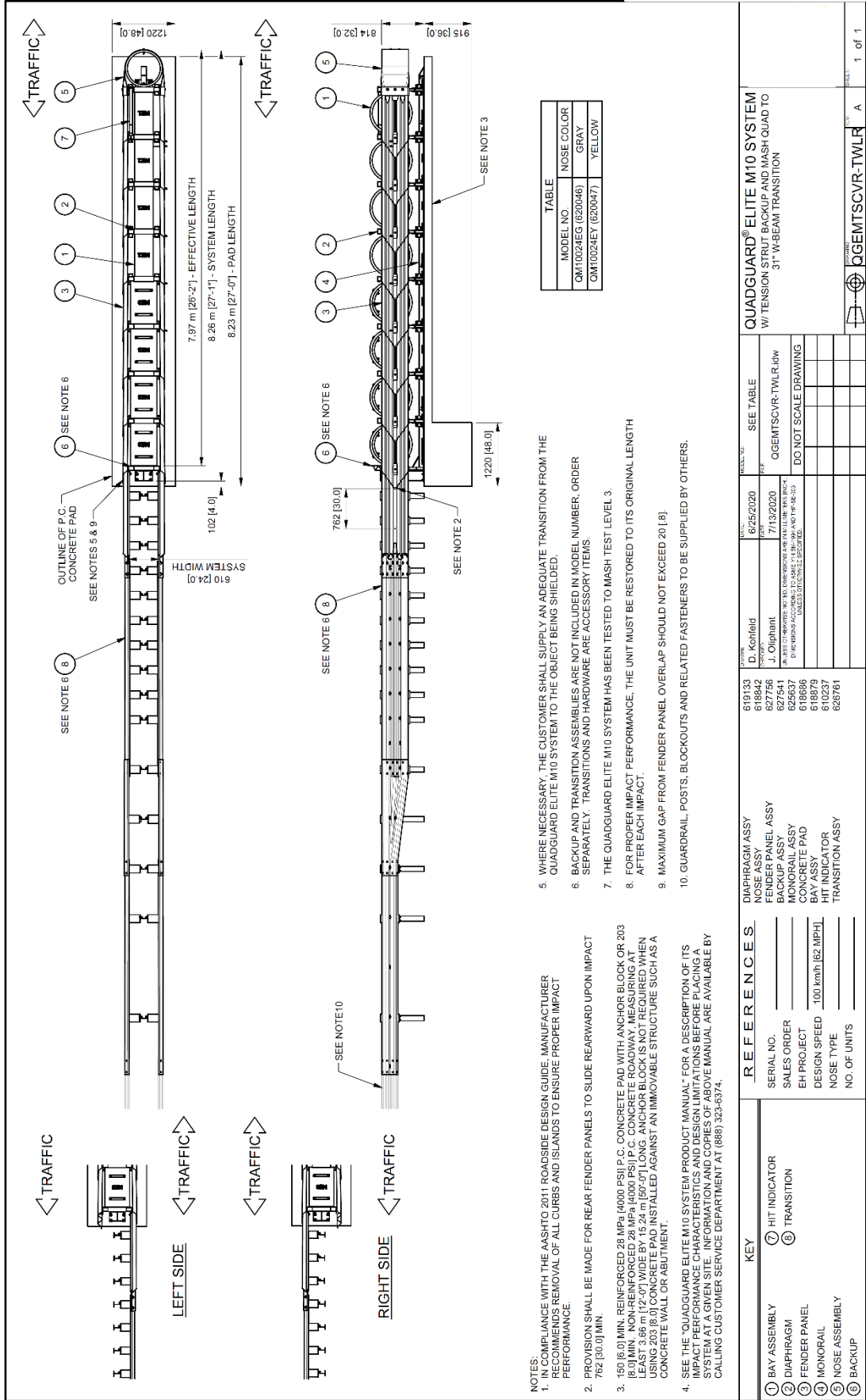
REFERENCES	
SERIAL NO.	DESCRIPTION
①	BAY ASSEMBLY
②	DIAPHRAGM
③	FENDER PANEL
④	MONORAIL
⑤	NOSE ASSEMBLY
⑥	BACKUP
⑦	HIT INDICATOR
⑧	END SHOE
⑨	WHEEL DEFLECTOR

REFERENCES	
SERIAL NO.	DESCRIPTION
①	BAY ASSEMBLY
②	DIAPHRAGM
③	FENDER PANEL
④	MONORAIL
⑤	NOSE ASSEMBLY
⑥	BACKUP
⑦	HIT INDICATOR
⑧	END SHOE
⑨	WHEEL DEFLECTOR

REFERENCES	
SERIAL NO.	DESCRIPTION
①	BAY ASSEMBLY
②	DIAPHRAGM
③	FENDER PANEL
④	MONORAIL
⑤	NOSE ASSEMBLY
⑥	BACKUP
⑦	HIT INDICATOR
⑧	END SHOE
⑨	WHEEL DEFLECTOR

- NOTES:
- IN COMPLIANCE WITH THE AASHTO 2011 ROADSIDE DESIGN GUIDE, MANUFACTURER RECOMMENDS REMOVAL OF ALL CURBS AND ISLANDS TO ENSURE PROPER IMPACT PERFORMANCE.
  - PROVISION SHALL BE MADE FOR REAR FENDER PANELS TO SLIDE REARWARD UPON IMPACT 762 [30.0] MIN.
  - 150 [6.0] MIN. REINFORCED 28 MPa [4000 PSII] P.C. CONCRETE PAD WITH ANCHOR BLOCK OR 203 [8.0] MIN. NON-REINFORCED 28 MPa [4000 PSII] P.C. CONCRETE ROADWAY. MEASURING AT LEAST 3.66 m [12'-0"] WIDE BY 15.24 m [50'-0"] LONG. ANCHOR BLOCK IS NOT REQUIRED WHEN USING 203 [8.0] CONCRETE PAD INSTALLED AGAINST AN IMMOVABLE STRUCTURE SUCH AS A CONCRETE WALL OR ABUTMENT.
  - SEE THE "QUADGUARD ELITE M10 SYSTEM PRODUCT MANUAL" FOR A DESCRIPTION OF ITS IMPACT PERFORMANCE CHARACTERISTICS AND DESIGN LIMITATIONS BEFORE PLACING A SYSTEM AT A GIVEN SITE. INFORMATION AND COPIES OF ABOVE MANUAL ARE AVAILABLE BY CALLING CUSTOMER SERVICE DEPARTMENT AT (888) 323-6374.
  - WHERE NECESSARY, THE CUSTOMER SHALL SUPPLY AN ADEQUATE TRANSITION FROM THE QUADGUARD ELITE M10 SYSTEM TO THE OBJECT BEING SHIELDED.
  - BACKUP AND TRANSITION ASSEMBLIES ARE NOT INCLUDED IN MODEL NUMBER. ORDER SEPARATELY. TRANSITIONS AND HARDWARE ARE ACCESSORY ITEMS.
  - THE QUADGUARD ELITE M10 SYSTEM HAS BEEN TESTED TO MASH TEST LEVEL 3.
  - FOR PROPER IMPACT PERFORMANCE, THE UNIT MUST BE RESTORED TO ITS ORIGINAL LENGTH AFTER EACH IMPACT.
  - MAXIMUM GAP FROM FENDER PANEL OVERLAP SHOULD NOT EXCEED 20 [8].
  - CONCRETE BARRIER WITH CHAMFERED CORNERS AT 1:4 RATE IS ACCEPTABLE IN PLACE OF WHEEL DEFLECTORS. IF BARRIER HEIGHT IS MORE THAN 813 [32], TRIM TOP AT 1:4 TAPER TO PREVENT VEHICLE CONTACT WITH BLUNT END.
  - CAUTION: CENTERLINE OF QUADGUARD ELITE M10 SYSTEM SHALL BE PARALLEL WITH CENTERLINE OF BARRIER ±1".
  - CAUTION: MAX. 864 [34.0] CLEARANCE BETWEEN BACKUP AND BARRIER WALL.

1 of 1



31" W-Beam Transition QGEMTSCVR-TWLR

KEY	DESCRIPTION	DATE	BY	APP'D	SCALE
①	BAY ASSEMBLY	6/25/2020	D. Kotheid		SEE TABLE
②	DIAPHRAGM	7/13/2020	J. Olliphant		QGEMTSCVR-TWLR.kdw
③	FENDER PANEL				DO NOT SCALE DRAWING
④	MONORAIL				
⑤	NOSE ASSEMBLY				
⑥	BACKUP				

REV	DESCRIPTION	DATE	BY	APP'D
1	ISSUE	6/25/2020	D. Kotheid	
2	REVISION	7/13/2020	J. Olliphant	

NO.	DESCRIPTION	DATE	BY	APP'D
1	QUADGUARD® ELITE M10 SYSTEM W/ TENSION STRUT BACKUP AND MASH QUAD TO 31" W-BEAM TRANSITION			

NO.	DESCRIPTION	DATE	BY	APP'D
1	QUADGUARD® ELITE M10 SYSTEM W/ TENSION STRUT BACKUP AND MASH QUAD TO 31" W-BEAM TRANSITION			

**Notes:**



For more complete information on Valtir products and services, visit us on the web at [www.valtir.com](http://www.valtir.com). Materials and specifications are subject to change without notice. Please contact Valtir to confirm that you are referring to the most current instructions.

**[WWW.VALTIR.COM](http://WWW.VALTIR.COM)**  
**1.888.323.6374**

