

Nu-Cable™

Cable Barrier Systems

INSTALLATION MANUAL

NU-TEN TERMINAL END
Version 2014.09A



It's Our Nature. 

CONTENTS

<u>TITLE</u>	<u>SECTION</u>
TERMINAL INSTALLATION	
NU-TEN	H
CHECKLIST	I
SYSTEM DELINEATION	J
APPENDIX	
SOILS	M
REPAIR	N
CONTACT	P

This manual is based upon the Armorflex Universal A.T.E Product Manual v. 160412 and has been modified from its original version to include information specific to the Nucor Nu-Cable® Cable Barrier System.

Product Manual

NU-TEN[®] Terminal End



Anchoring for 3 & 4 Cable Barriers

Proudly distributed by



It's Our Nature. 

Table of Contents

BJM(v8)



Armorflex International Limited

160412

NU-TEN® TERMINAL END Introduction.....	3
System Overview.....	3
Limitations and Warnings.....	3
Before Installation.....	4
Safety Statements.....	4
Limited Warranty.....	5
Geotechnical Warning.....	5
Design Considerations.....	6
System Design.....	7
Parts Identification.....	10
Installation Preparation.....	11
Bill of Materials.....	12
Installation Instructions	13
Installation Examples.....	18
Installation Checklist.....	19
Frequently Asked Questions.....	20

APPENDIX – Technical Drawings

NU-TEN® TERMINAL END (3 Cable).....	21
NU-TEN® TERMINAL END (4 Cable).....	22
NU-TEN® TERMINAL END - Overlap.....	23
NU-TEN® TERMINAL END - 3 & 4 Cable Line Post Set Up.....	23
NU-TEN® TERMINAL END - Clearzone.....	23
NU-TEN® TERMINAL END – Foundation Options.....	24

NU-TEN® TERMINAL END Introduction

Introduction

The **NU-TEN® TERMINAL END** is used to anchor **Nu-Cable** high tensioned 3 or 4 cable barriers. All cables connect to the unique 'trigger' post which is attached to the ground strut, while concrete foundations and rebar cages complete the anchor set-up.

The **NU-TEN® TERMINAL END** has been designed and tested to meet the evaluation criteria of NCHRP 350 Test Level 3 (TL-3) for a cable barrier terminal end.

System Overview

The **NU-TEN® TERMINAL END** is designed and constructed to provide acceptable structural adequacy, minimal occupant risk and safe trajectory as set forth in NCHRP 350 for cable barrier terminal ends.

When impacted with an 820kg and 2000kg vehicle at speeds of 100kph, due to the immediate loss of cable tension, the errant vehicle remains on its wheels at all times without vaulting or rolling which is common on terminal ends where cables remain tensioned during impact.

When the 'trigger' post is impacted all cables disconnect causing the system to be de-tensioned immediately. During end on impacts the vehicle pushes the anchor cables down and out of the 'trigger' post. While during re-directive or reverse angle impacts, the cables disconnect out from the top of the 'trigger' post.

The Length of Need (LoN) of the **NU-TEN® TERMINAL END** is 8m downstream from the 'trigger' post. The first 4 line posts after the 'trigger' post are always at 2m spacing.

Limitations and Warnings

The **NU-TEN® TERMINAL END** has been rigorously tested and evaluated per the evaluation criteria in the NCHRP 350 guidelines for gating, re-directive cable barrier terminal end. The impact conditions recommended in NCHRP 350 are intended to address typical in-service collisions.

The **NU-TEN® TERMINAL END** allows an impacting vehicle to remain on its wheels in a safe and predictable manner under the NCHRP 350 impact conditions. It is imperative that the system is installed as per manufacturers' specification.

Vehicle impacts that vary from the NCHRP 350 impact conditions described for cable barrier terminal ends may result in significantly different results than those experienced in testing. Vehicle impact characteristics different than, or in excess of, those encountered in NCHRP 350 testing (weight, speed and angle) may result in system performance that may not meet the NCHRP 350 evaluation criteria.

Before Installation

Design, selection and placement of the **NU-TEN® TERMINAL END** must be in accordance with the Road Controlling Authority's guidelines and the details shown in the project construction drawings. These installation instructions are for illustrative purposes only.

Note: Concrete foundations will have to be designed by a local geotechnical engineer if soil conditions on site do not meet the required level described in the manual.

Depending on the application and circumstances at the site, installation and assembly of the system should take one person less than 15mins once the concrete foundations are poured and set.

The **NU-TEN® TERMINAL END** is a highly engineered safety device made up of a relatively small number of parts. Before starting installation ensure that one is familiar with the make up and proper installation of the terminal end.

Safety Statements

General Safety

- All required traffic safety precautions should be complied with. All workers should wear required safety clothing. (Examples, and not limited to, include: high visibility vests, steel capped footwear, gloves etc.)
- Only authorized trained personnel should operate any machinery. Where overhead machinery is used, care must be taken to avoid any overhead hazards.
- Before drilling or excavation always ensure that the area is clear of underground services. (The appropriate service providers may need to be contacted)

NU-TEN® TERMINAL END Safety Statements

- All installers must be well clear of drilling or excavating machinery operating.
- The components are not heavy enough to require specialised lifting equipment, but due to the dimensions and bulky nature, care should be taken when lifting the larger components into position. If the ground strut and rebar cage assembly is assembled prior to installation, suitable lifting equipment will be required.
- Avoid placing hands or fingers in and around moving machine parts when components are being lifted and manoeuvred into place.

Limited Warranty

Nucor Steel Marion Inc. (NUCOR) has tested the impact performance of its barriers and crash cushion systems, and other highway safety hardware under controlled conditions, however, NUCOR does not represent nor warrant that the results of those controlled conditions would necessarily avoid injury to persons or property.

NUCOR EXPRESSLY DISCLAIMS ANY WARRANTY OR LIABILITY FOR CLAIMS ARISING BY REASONS OF DEATH OR PERSONAL INJURY OR DAMAGE TO PROPERTY RESULTING FROM ANY IMPACT, COLLISION OR HARMFUL CONTACT WITH THE PRODUCTS OR NEARBY HAZARDS OR OBJECTS BY ANY VEHICLE, OBJECTS OR PERSONS.

NUCOR warrants that any product or component part manufactured by NUCOR will be free from defects in material or workmanship. NUCOR will replace free of cost any Product or component part manufactured by NUCOR that contains such a defect.

THE FOREGOING WARRANTY IS IN LIEU OF AND EXCLUDES ALL OTHER WARRANTIES NOT EXPRESSLY SET FORTH HEREIN, WHETHER EXPRESS OR IMPLIED BY OPERATION OF LAW OR OTHERWISE, INCLUDING BUT NOT LIMITED TO ANY IMPLIED WARRANTIES OF MERCHANTABILITY OR FITNESS FOR A PARTICULAR PURPOSE.

NUCOR'S LIABILITY UNDER THIS WARRANTY ONLY APPLY TO PARTS NUCOR MANUFACTURE AND IS EXPRESSLY LIMITED TO REPLACEMENT FREE OF COST OF PARTS SUPPLIED BY NUCOR ONLY (IN THE FORM AND UNDER THE TERMS ORIGINALLY SHIPPED), OR TO REPAIR OR TO MANUFACTURE BY NUCOR, PRODUCTS OR PARTS NOT COMPLYING WITH NUCOR SPECIFICATIONS, OR, AT NUCOR'S ELECTION, TO THE REPAYMENT OF AN AMOUNT EQUAL TO THE PURCHASE PRICE OF SUCH PRODUCTS OR PARTS, WHETHER SUCH CLAIMS ARE FOR BREACH OF WARRANTY OR NEGLIGENCE. NUCOR SHALL NOT BE LIABLE FOR ANY INCIDENTAL, CONSEQUENTIAL OR SPECIAL LOSSES, DAMAGES OR EXPENSES OF ANY KIND, INCLUDING, WITHOUT LIMITATION, ANY SUCH LOSSES, DAMAGES OR EXPENSES ARISING DIRECTLY OR INDIRECTLY FROM THE SALE, HANDLING OR USE OF THE PRODUCTS FROM ANY OTHER CAUSE RELATING THERETO, OR FROM PERSONAL INJURY OR LOSS OF PROFIT.

Any claim by the Buyer with reference to Products sold hereunder for any cause shall be deemed waived by the Buyer unless NUCOR is notified in writing, in the case of defects apparent on visual inspection, within ninety (90) days from the delivery date, or, in the case of defects not apparent on visual inspection, within twelve (12) months from the said delivery date. Products claimed to be defective may be returned prepaid to NUCOR's plant for inspection in accordance with return shipping instructions that NUCOR shall furnish to the Buyer forthwith upon receipt of the Buyer's notice of claim. If the claim is established, NUCOR will reimburse that Buyer for all carriage costs incurred hereunder.

The forgoing warranty benefits shall not apply to (i) any Products that have been subject to improper storage, accident, misuse or unauthorized alterations, or that have not been installed, operated and maintained in accordance with approved procedures and (ii) any components manufactured by the Buyer.

Geotechnical Warning

The **NU-TEN® TERMINAL END** concrete foundations require sufficient strength from the supporting soil and guidelines contained within this manual on foundation sizes relate specifically to the corresponding soil strength. If it is determined that soil conditions on site do not meet or exceed these requirements, alternative size foundations must be designed by a local geotechnical engineer for use at that location.

Design Considerations

Curbs

As with all road side safety hardware, the **NU-TEN® TERMINAL END** has been designed and tested so that the centre of gravity of the impacting vehicle is at a constant height in relation to the system. For this reason, it is preferred that curbs or channels are not in front or behind the terminal end as they will result in altering the height of the vehicle at impact. If there is no option but to install near a curb advice should be followed from the Road Controlling Authority's guidelines.

Undulating Ground Conditions

Site specific grading may be necessary to ensure that there are no 'humps' or 'hollows' that may significantly alter the impacting vehicles stability or substantially alter the cable heights in relation to the ground. The ground strut is required to lay flush with the foundations and must not protrude more than 100mm from ground level, when measured using a 1500mm cord pulled along the centreline of the anchor assembly.

Flare Rate

The preference is to not flare the system, as flaring may affect structural integrity. If this is unavoidable then the maximum flare rate should be 30:1 over the entire length of the terminal end and the installer is responsible for determining the appropriateness of the flare rate.

Clearzone

The **NU-TEN® TERMINAL END** is a gating, non-energy absorbing terminal end and therefore requires a clearzone directly behind as recommended by Road Controlling Authority guidelines. The minimum size of the clearzone should be an area 22.5m long by 6m wide, reasonably traversable and free from fixed object hazards.
(See drawing in Appendix)

Tension

The **NU-TEN® TERMINAL END** is designed to anchor **Nu-Cable** 3 and 4 high tensioned cable barriers. Please refer to the relevant literature for instructions on how to tension the barrier that is being installed.

Note: Do **NOT** tension a barrier for 7 days after the foundations have been cast.

Line Posts

The 4 line posts (posts #2 - #5 where post #1 is the 'trigger' post) that make up the remainder of the **NU-TEN® TERMINAL END** are to be installed as per manufacturers' instructions. The spacing of these posts must **ALWAYS** be at 2m spacing.

System Design

Foundation Options

For the **NU-TEN® TERMINAL END** to provide sufficient anchoring strength to the cable barrier it relies on the design of the concrete foundation and the surrounding soil conditions on site. Soil conditions have different characteristics that will affect the strength of the concrete foundations and accordingly the **NU-TEN® TERMINAL END** has a range of foundations options which allow for economical construction, while still maintaining the performance levels required.

IF SOIL CONDITIONS ON SITE DO NOT MEET OR EXCEED THE REQUIRED STRENGTH DETAILED IN THIS MANUAL, SITE SPECIFIC FOUNDATIONS MUST BE DESIGNED BY A LOCAL GEOTECHNICAL ENGINEER

Note: All technical information required to assist in designing a site specific foundation is available from your **NU-TEN® TERMINAL END** distributor as a **Foundation Assistance Package**.

Three foundation options are available in this manual; the soil conditions that exist on site will determine which one can be used.

Option 1:

TO CONSIDER THE USE OF OPTION 1, THE TESTED SOIL CONDITION MUST MEET OR EXCEED THE STRENGTH DETAILED IN TABLE 1 BELOW

Cohesive Soils		
Soil Type	Description Su (kpa)	Foundation Depth
<i>Firm - Stiff</i>	51 - 100	450mm ø x 2500mm
Cohesionless Soils		
Soil Type	Description Phi (0)	Foundation Depth
<i>Dense - Medium Dense</i>	30 - 41	450mm ø x 2500mm

* G&A 24 Sept 2009 # 077812115/06 Rev 1.

Table 1.

The ground strut and 2000mm long rebar cage assembly must be cast into concrete foundations with the following dimensions. The augured holes for this option are 450mm diameter by 2500mm deep and must be filled with 25mpa concrete. The rebar cages are located centrally in the foundation. (shown in Figure A)

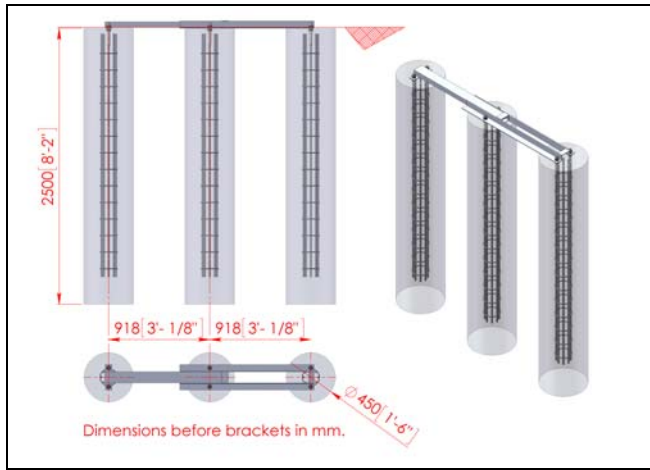

Figure A.
System Design cont

Option 2:

TO CONSIDER THE USE OF OPTION 2, THE TESTED SOIL CONDITION MUST MEET OR EXCEED THE STRENGTH DETAILED IN TABLE 2 BELOW

Cohesive Soils		
Soil Type	Description Su (kpa)	Foundation Depth
<i>Very Stiff</i>	101 - 125	450mm \varnothing x 1500mm

* G&A 24 Sept 2009 # 077812115/06 Rev 1.

Table 2.

The ground strut and 1200mm long rebar cage assembly must be cast into concrete foundation with the following dimensions. The augured holes for this option are 450mm diameter by 1500mm deep filled with 25mpa concrete. The rebar cages are located centrally in the foundations. (shown in Figure B)

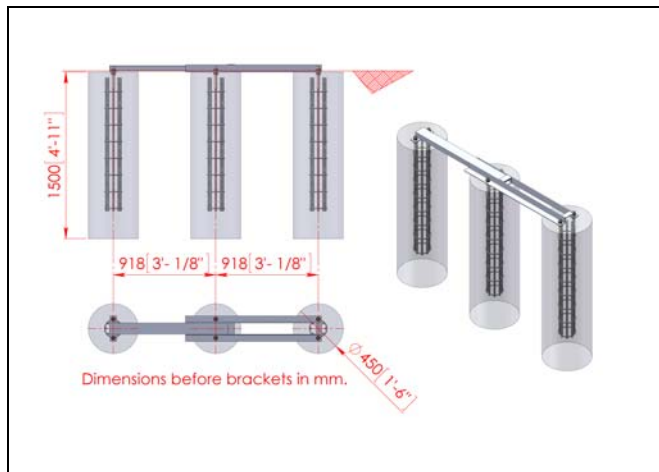

Figure B.

Option 3:

OPTION 3 IS FOR USE IN EXTREMELY POOR SOIL. TO CONSIDER THE USE OF OPTION 3, CONDITIONS ON SITE MUST MATCH THE BELOW DESCRIPTION

- WATER TABLE IS AT GROUND SURFACE
- COHESION IS ZERO
- 'ANGLE OF INTERNAL FRICTION' IS A MINIMUM OF 30 DEGREES

Assumptions

- Saturated unit weight of soil is at least 1800 kg/m³ (112 lbs/ft³)
- Effective unit weight of soil is at least 800 kg/m³ (50 lbs/ft³)
- Unit weight of concrete in air is at least 2550 kg/m³ (159 lbs/ft³)
- Effective unit weight of concrete submerged is at least 1550 kg/m³ (97 lbs/ft³)

* G&A 27 May 2009 # 077812115/10

The ground strut and 2000mm long rebar cage assembly must be cast into a concrete block with the following dimensions. The excavated hole for this option is 1830mm wide by 4580mm wide and 2440mm deep filled with 25mpa concrete. The rebar cages should be located in the centre widthways of the monolithic block but offset lengthways at 300mm from the trigger post end of the ground strut assembly. (shown in Figure C)

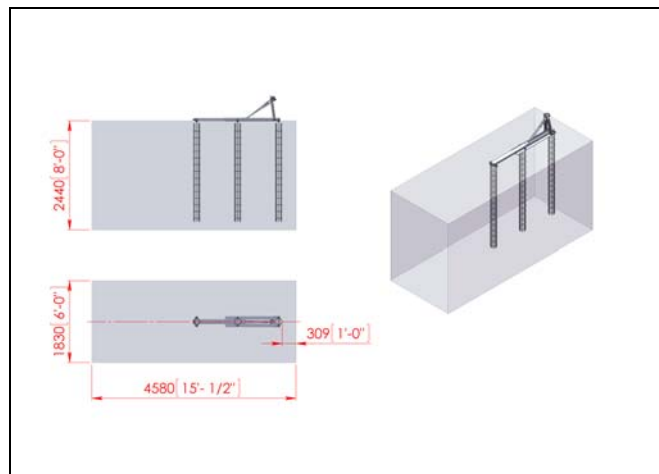

Figure C.

Length of Need (LoN)

The Length of Need (LoN) for an **Nu-Cable** cable barrier connected to a **NU-TEN® TERMINAL END** is at post #5, where post #1 is the 'trigger' post. Posts #2 - #5 are always at 2m spacing; therefore the LoN is 8m from the 'trigger' post. (shown in Figure D)

Note: For definition and instructions in determining the appropriate length of need for a barrier at a specific location, please reference the AASHTO Roadside Design Guide. As per the LoN design section of the Road Controlling Authority's guidelines, care must be taken when calculating the actual length of the barrier required versus the theoretical length of the LoN. The physical placement of the **NU-TEN® TERMINAL END** must be with post #5 positioned at the LoN.

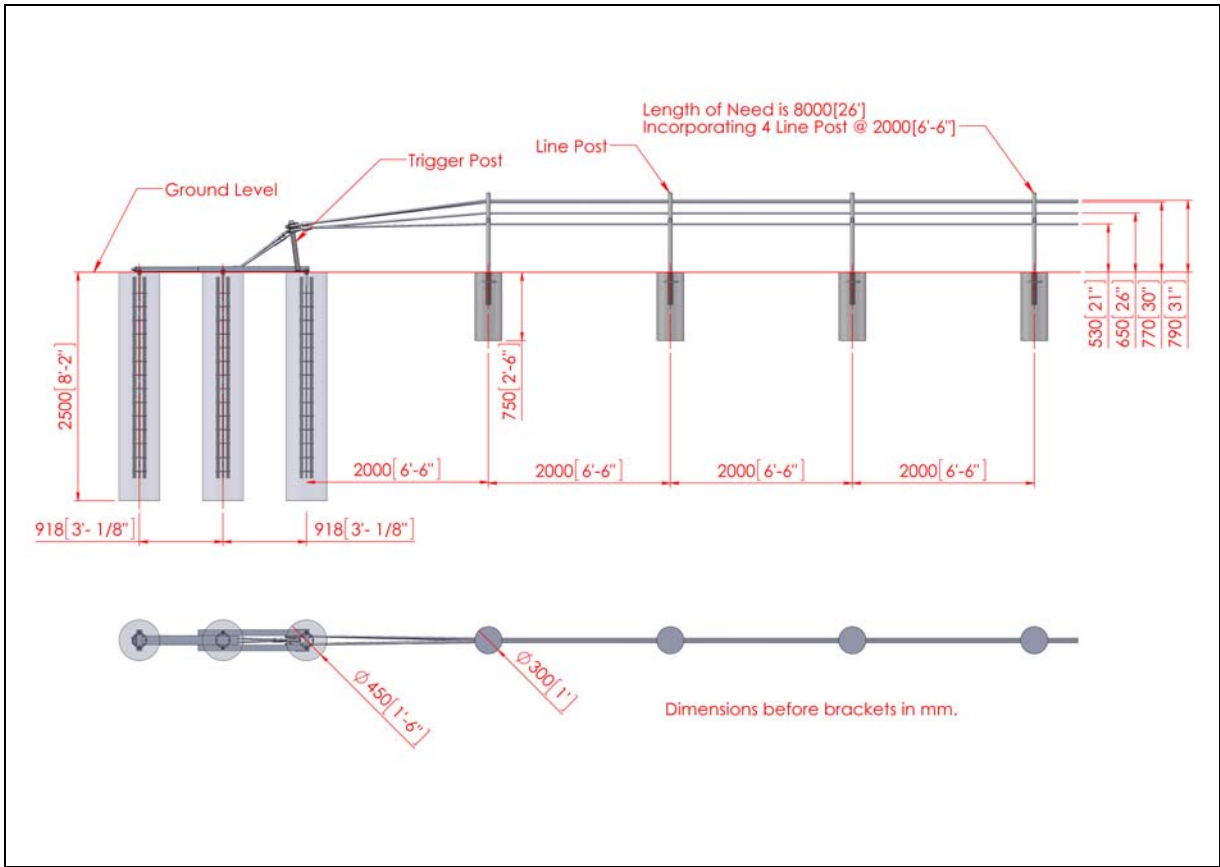
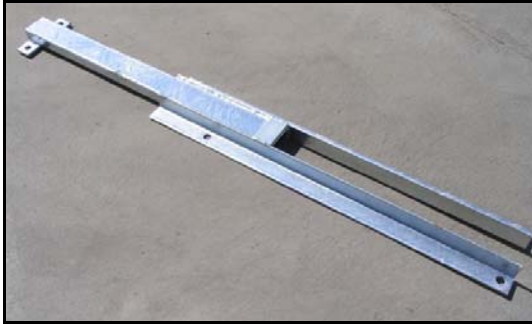

Figure D*.

* Foundation Option shown for visual representation only.

NU-TEN® TERMINAL END - Parts Identification



Ground Strut



* Type of cage shown for visual representation only.

Rebar Cages

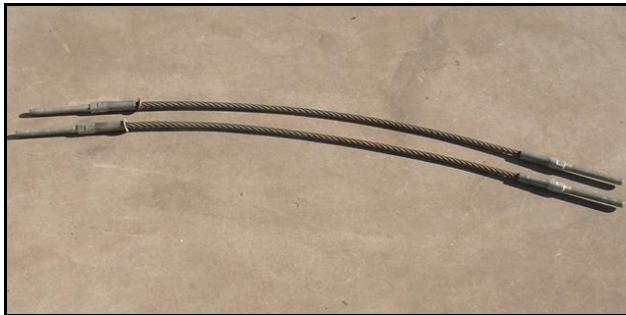

Anchor Cables

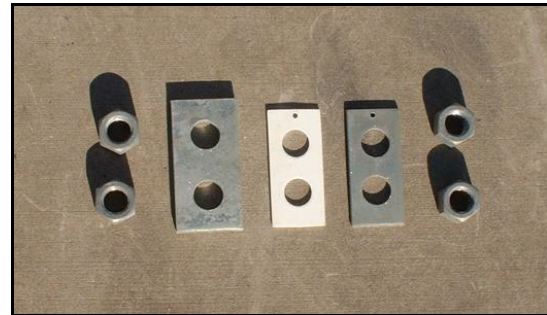

Washers & Nuts



Trigger Post



Cable Grips*



Cable Grips*

* For each cable grip a M24 steel nut, 3mm thick polyethylene square washer and a 6mm thick steel round washer is also required. Shown above are the cable grip and fitting requirements for a 3 and 4 cable barrier respectively.

All steel components used in the NU-TEN® TERMINAL END are hot dipped galvanized, except the rebar cages which are cast into the concrete foundations.

NU-TEN® TERMINAL END - Installation Preparation

Getting Started

The **NU-TEN® TERMINAL END** is a cable barrier terminal end designed to anchor either 3 or 4 cable barriers. For all installations, whether median or edge of road locations, start from the last post of the cable barrier. The 4 line posts between the end of the cable barrier and the **NU-TEN® TERMINAL END** 'trigger' post must always be at 2m spacing.

Before installing a **NU-TEN® TERMINAL END**, ensure that all components required for the system are on site and have been identified. The **NU-TEN® TERMINAL END** is a highly engineered safety device made up of relatively small number of parts. Before starting installation ensure that one is familiar with the make up and proper installation of the system. Refer to the **Bill of Materials** and **Parts Identification** sections in this manual for more information.

Ensure that the area where the **NU-TEN® TERMINAL END** is to be installed is flat enough so that the ground strut will not protrude more than 100mm from ground level, when measured using a 1500mm cord pulled along the centreline of the anchor assembly.

Minor site grading may be required.

Soil Conditions

The **NU-TEN® TERMINAL END** foundation options contained in this manual have been designed to withstand a constant static load and dynamic impact load that can be exerted on it from the tensioned barrier cables. It is extremely important that the **NU-TEN® TERMINAL END** has the required strength to anchor the cable barrier.

Refer to the **Foundation Options** in the **System Design** section in this manual for more information.

It is recommended that soil tests are carried out at each location the **NU-TEN® TERMINAL END** is to be installed in order to determine an appropriate foundation design.

IF SOIL CONDITIONS ON SITE DO NOT MEET OR EXCEED THE REQUIRED STRENGTH DETAILED IN THIS MANUAL, SITE SPECIFIC FOUNDATIONS MUST BE DESIGNED BY A LOCAL GEOTECHNICAL ENGINEER

Tools Required

Generally, the same tools required to install the cable barrier will also be used to install a **NU-TEN® TERMINAL END**:

- Drilling or excavating machinery suitable for foundation design
- Concrete trowel or float
- 300mm Wrench
- Measuring tape
- String line

The installer must determine the appropriate tools for proper installation of the **NU-TEN® TERMINAL END**.

NU-TEN® TERMINAL END - Bill of Materials

NU-TEN® TERMINAL END (connected to a 4 Cable barrier)

- 1x Ground Strut
- 3x Rebar Cages (c/w 12x M24 nuts)
- 1x Trigger Post
- 2x Anchor Cables (c/w 4 x M24 nuts)
- 1x 10mm thick Rectangular Steel Washer
- 1x 6mm thick Rectangular Steel Washer
- 1x 3mm thick Rectangular Polyethylene Washer
- 4x 3mm thick Square Polyethylene Washers
- 4x 6mm thick 50mm ø Steel washers

NU-TEN® TERMINAL END (connected to a 3 Cable Barrier)

- 1x Ground Strut
- 3x Rebar Cages (c/w 12x M24 nuts)
- 1x Trigger Post
- 2x Anchor Cables (c/w 4 x M24 nuts)
- 1x 10mm (thick) Rectangular Steel Washer
- 1x 6mm (thick) Rectangular Steel Washer
- 1x 3mm (thick) Rectangular Polyethylene Washer
- 3x 3mm (thick) Square Polyethylene Washer
- 3x 6mm thick 50mm ø Steel washers

NU-TEN® TERMINAL END - Installation Instructions

Step 1 – Site Preparation

It is preferred that the **NU-TEN® TERMINAL END** be installed on flat, level ground. The **NU-TEN® TERMINAL END** starts at the last post of the cable barrier and the setup is always the same configuration over its 10m length.

The **NU-TEN® TERMINAL END** is a continuation of the cable barrier and should be installed in line with the cable barrier. If this is not possible, a maximum flare rate of no more than 30:1 is permissible. (Reference Flare Rate page H-7)

The 4 line posts between the **NU-TEN® TERMINAL END** 'trigger' post and the cable barrier must always be at 2m spacing.

**BEFORE DRILLING OR EXCAVATION ALWAYS ENSURE
THAT THE AREA IS CLEAR OF UNDERGROUND SERVICES**

NU-TEN® TERMINAL END - Installation Instructions

Step 2 – Installing the Ground Strut

Foundation Construction

Excavate or drill the area that the NU-TEN® TERMINAL END is to be located as per the foundation option required. (shown in Figure 1)

All technical information on the 3 foundation options available, or for guidance on site specific foundations design, is located in the **System Design** section in this manual under **Foundation Options**.

DO NOT PROCEED PAST THIS POINT IF THE TYPE OF FOUNDATION REQUIRED HAS NOT BEEN ESTABLISHED

Ground Strut and Rebar Cage Assembly

Attach each rebar cage to the ground strut using M24 nuts, one below and one above the ground strut. (shown in Figure 2)

At least 15mm of thread above the top nut must be showing on ALL threads.

Note: This assembly can take place either pre-installation or in position on site. Depending on type of rebar cages used, suitable lifting equipment will be required.

Construction

The foundation can be constructed in two ways. Either fill the foundation excavation to the top with concrete and insert the rebar cage assembly, or manoeuvre the rebar cage assembly into the foundation excavation and then fill with concrete. (shown in Figure 3)

Which technique to use will be dependent on the foundation used and type of rebar cage. Position of the rebar cage assembly must be in accordance with the foundation design.

Note: The hollow RHS end of the ground strut is always at the end furthest from the cable barrier and needs to be flush with the concrete level. (shown in Figure 3)



Photo 1*.



Photo 2*.

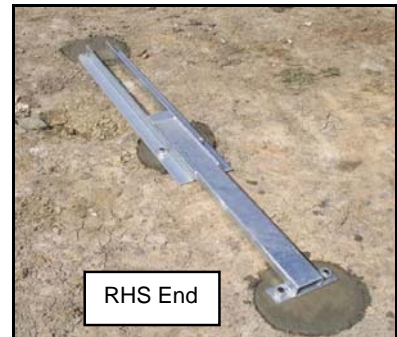

Photo 3*.

Note: Due to the drilling and removing spoil the actual amount of concrete required is likely to be larger than the theoretical volume. Concrete must be 25mpa.

* Foundation Option shown for visual representation only.

NU-TEN® TERMINAL END - Installation Instructions

Step 3 – Installing the Anchor Cables

Once the concrete for the foundation has had sufficient time to harden, no less than 7 days, the anchor cables can be connected to the ground strut. (shown in Figure 4)

Hold both anchor cables at once and slot down through the RHS end of the ground strut.

The 10mm thick rectangular steel washer is placed onto the threads at the upstream end of the ground strut and the M24 nuts can be then wound on. (shown in Figure 5)

Note: Only wind on by 1 or 2 threads at this stage, they are fully tightened later in **Step 5**.



Figure 4*.



Figure 5*.

At the other end of the anchor cables the 3mm thick polyethylene rectangular washer is placed onto the threads first, followed by the 6mm thick steel rectangular washer. The M24 nuts can then be wound on. (shown in Figures 6 & 7)

Note: Only wind on by 1 or 2 threads so there is sufficient room in the 'trigger' post to house the cable grips.



Figure 6*.



Figure 7*.

* Foundation Option shown for visual representation only.

NU-TEN® TERMINAL END - Installation Instructions

Step 4 – Connecting the Trigger Post

Remove the two M24 nuts on the top side of the downstream end of the ground strut. The 'trigger' post can then be placed on the exposed threads and the nuts re-attached and tightened with a wrench. (shown in Figures 8 & 9)

Note: At least one thread must be wound through the nuts when re-attached.

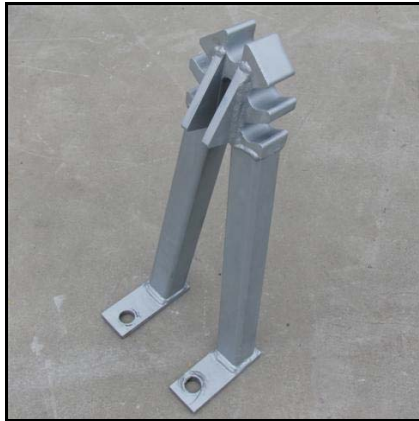

Figure 8*.



Figure 9*.

Step 5 – Connecting the Anchor Cables to the Trigger Post

The anchor cables with washers are positioned onto the triangular wedges on the 'trigger' post. The anchor cables are then tightened with a wrench by turning the nuts at the upstream end of the ground strut until taut. (shown in Figures 10 & 11)

Note: An open end wrench may be required due to space constraints.



Figure 10*.



Figure 11*.

MAKE SURE THE ANCHOR CABLES ARE FULLY HOUSED WITHIN THE 'TRIGGER' POST.

* Foundation Option shown for visual representation only.

NU-TEN® TERMINAL END - Installation Instructions

Step 6 – Connecting to a 3 Cable Barrier

Place the top cable from the cable barrier in the top slot of the 'trigger' post and the bottom two cables on either side in the bottom slots. (shown in Figures 12 & 13)

Make sure that the 3mm thick polyethylene square washer is positioned between the 6mm thick steel round washer and the 'trigger' post on each cable.



Figure 12*.



Figure 13*.

OR

Step 6 – Connecting to a 4 Cable Barrier

Place the top 2 cables from the cable barrier in the top slots on either side of the 'trigger' post and the bottom two cables on either side in the bottom slots. (shown in Figures 14 & 15)

Make sure that the 3mm thick polyethylene square washer is positioned between the 6mm thick steel round washer and the 'trigger' post on each cable.



Figure 14*.



Figure 15*.

NOTE: DO NOT TENSION THE BARRIER UNTIL AT LEAST 7 DAYS AFTER THE ANCHOR FOUNDATIONS HAVE BEEN CAST.

* Foundation Option shown for visual representation only.

NU-TEN® TERMINAL END - Installation Instructions

Step 7 – Delineation

Delineation may be required as per the Road Controlling Authority guidelines.

For further details including type, location and placement contact your nearest **Nu-Cable** distributor.

NU-TEN® TERMINAL END – Installation Examples



NU-TEN® TERMINAL END connected to a 3 cable barrier*



NU-TEN® TERMINAL END connected to a 4 cable barrier*

* Foundation Option shown for visual representation only.

INSTALLATION CHECKLIST FOR THE NU-TEN® TERMINAL END

Location			
Installed By		Date	
Inspected By		Date	
			Y/N
			N/A
<p>General</p> <ul style="list-style-type: none"> • The ground strut does not protrude more than 100mm when measured using a 1500mm cord along its centreline. • The M24 nuts holding the ground strut to the foundation are spanner tight. • The 10mm thick steel rectangular washer has been used to fix the anchor cables to the upstream end of the ground strut. • The 3mm thick polyethylene rectangular washer and 6mm thick steel rectangular washer are used to fix the anchor cables to the 'trigger' post (see diagram below). • The anchor cables are firmly held in the body of the triangular wedges on the 'trigger' post and the M24 nuts at the upstream end of the ground strut are spanner tight. <p>Connected to a 3 Cable Barrier</p> <ul style="list-style-type: none"> • The top cable of the cable barrier is positioned in the top slot on the 'trigger' post. • The two bottom cables are positioned on either side of the 'trigger' post in the bottom slots. • The 3mm thick square polyethylene washer is between the 6mm round steel washer and the 'trigger' post for all three cables. (see diagram below) <p>Connected to a 4 Cable Barrier</p> <ul style="list-style-type: none"> • The two top cables of the cable barrier are positioned on either side of the 'trigger' post in the top slots. • The two bottom cables are positioned on either side of the 'trigger' post in the bottom slots. • The 3mm thick square polyethylene washer is between the 6mm round steel washer and the 'trigger' post for all four cables. (see diagram below) 			
			

Comments:

NU-TEN® TERMINAL END – F.A.Q

1) What type of equipment is required to install the NU-TEN® TERMINAL END?

Standard tools required include a wrench, measuring tape, string line and trowel. Machinery suitable for drilling or excavating the foundations.

2) How much concrete is required to install the concrete foundations on a NU-TEN® TERMINAL END and what strength does it need to be?

The volume will vary depending on the type of foundation being used. There are three foundation options contained in this manual and the corresponding theoretical volumes are: Option 1 = 1.39m³, Option 2 = 0.92m³, Option 3 = 20.65m³. (includes 4 line post footings)
The concrete used must be 25mpa.

(Due to the drilling and removing spoil the actual amount may differ.)

Note: Other foundation sizes and types might be required due to on site soil conditions. Concrete volume requirements will vary accordingly.

3) Is there a curing period for the concrete before the barrier can be tensioned?

Yes, do not tension until at least 7 days after the concrete footings have been poured.

4) Does your company provide spare parts? What is the lead-time for supply?

It is important to fix a damaged cable barrier as soon as possible because it most probably won't perform as required when damaged. For this reason it is recommended that spares are held by Maintenance Contractors. (the concrete footings and ground strut assembly are very unlikely to be damaged)

5) On average, how long does it take to install a NU-TEN® TERMINAL END?

Depending on circumstances at the site, installation and assembly of the system should take one person crew less than 15mins once the concrete foundations are poured and set.

6) What about vandalism, can the NU-TEN® TERMINAL END be easily damaged?

No, once the system has been tensioned it is an extremely rigid system and tampering without the use of heavy duty tools or machinery is very unlikely to damage or affect the performance of the system.

7) How easily can the NU-TEN® TERMINAL END and Nu-Cable Cable Barrier be restored after impact?

Nu-Cable is the simplest cable barrier to fix on the market and including the **NU-TEN® TERMINAL END**, the system is easily repaired after impact. Damaged line posts can be removed using a crow bar and new ones positioned in the sockets before the cables and caps are repositioned. It is recommended that the cable tension is checked after impact.

If the system has been de-tensioned due to damage to the 'trigger' post, a hydraulic tension machine and trained personnel will be required to re-tension the system after the 'trigger' post is replaced. The foundations and ground strut should not be damaged in anyway.

8) What maintenance does the NU-TEN® TERMINAL END require?

The **NU-TEN® TERMINAL END** terminal end is maintenance free as the anchor cables used are pre-stretched. Refer to the relevant **Nu-Cable** Product Manual for recommendations on maintenance for the cable barrier itself which includes cable tension checking.

9) Apart from the configuration of the cables from the cable barrier onto the 'trigger' post, are there any other differences between installing a 3 or 4 cable barrier to a NU-TEN® TERMINAL END?

No, the setup of the **NU-TEN® TERMINAL END** terminal end apart from how the cables connect to the 'trigger' post is always the same. (N.B. Foundations required are site specific)

APPENDIX – Technical Drawings

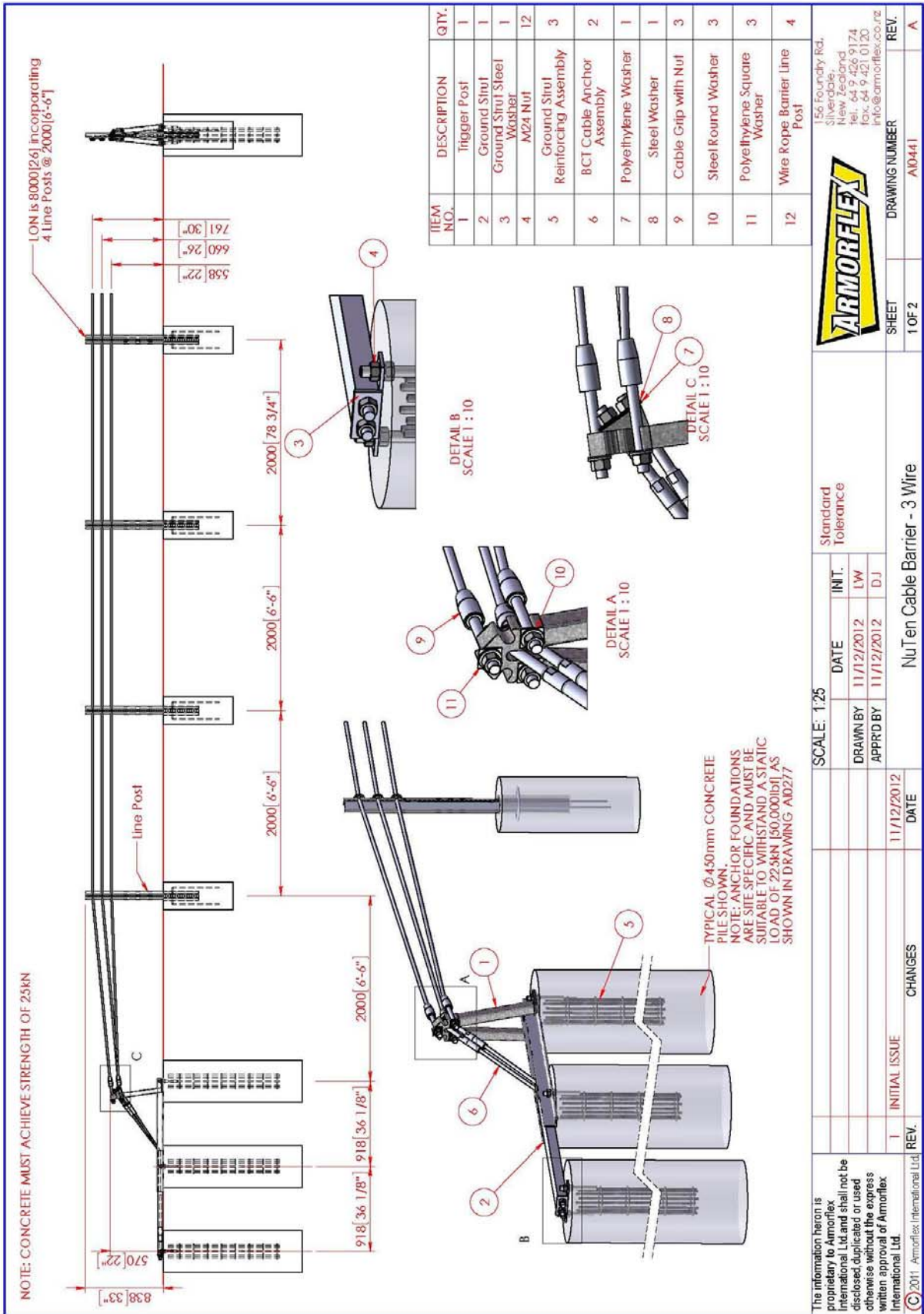

NU-TEN® TERMINAL END - 3 Cable Connection*

APPENDIX – Technical Drawings (continued)

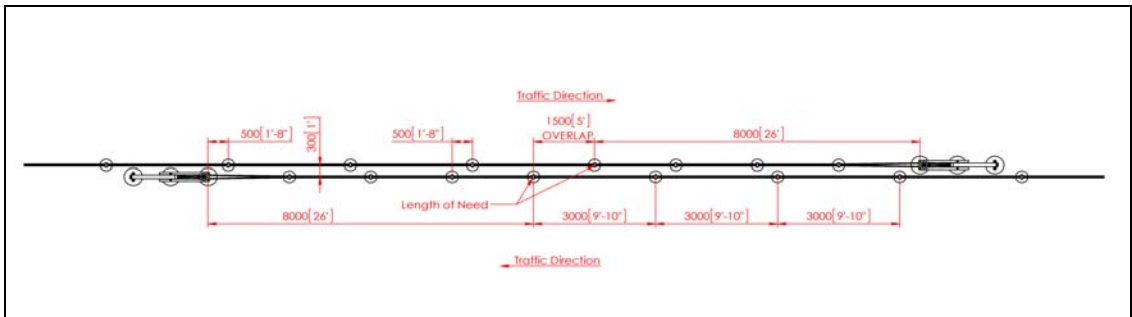

NU-TEN® TERMINAL END – Overlap*

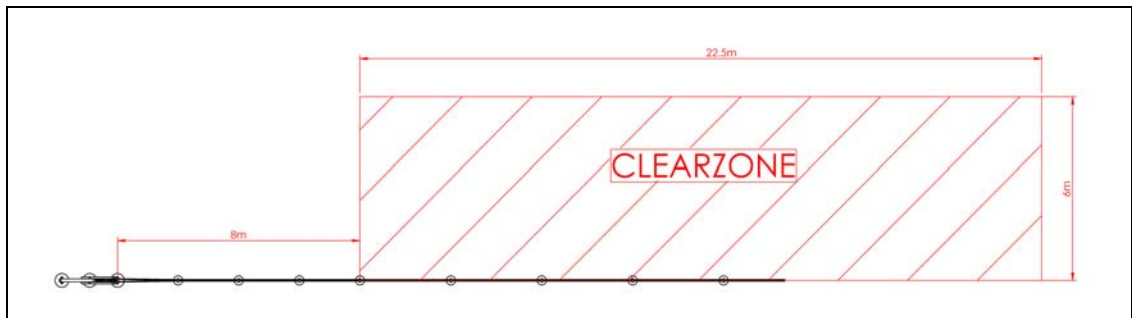

NU-TEN® TERMINAL END – Clearzone*

* Foundation Option shown for visual representation only.

APPENDIX – Technical Drawings (continued)

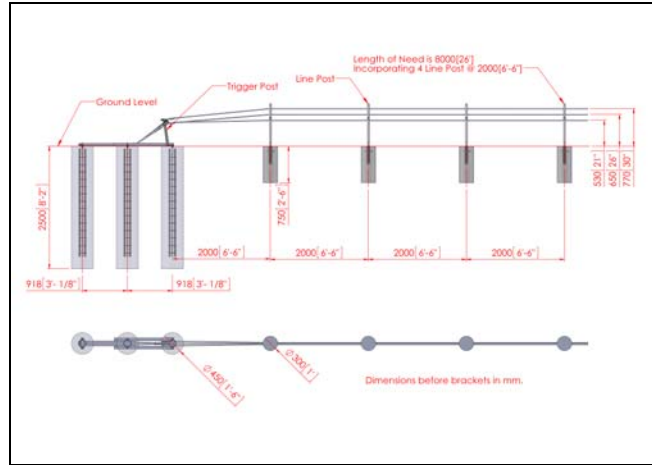

NU-TEN® TERMINAL END – Set-up (Option 1)

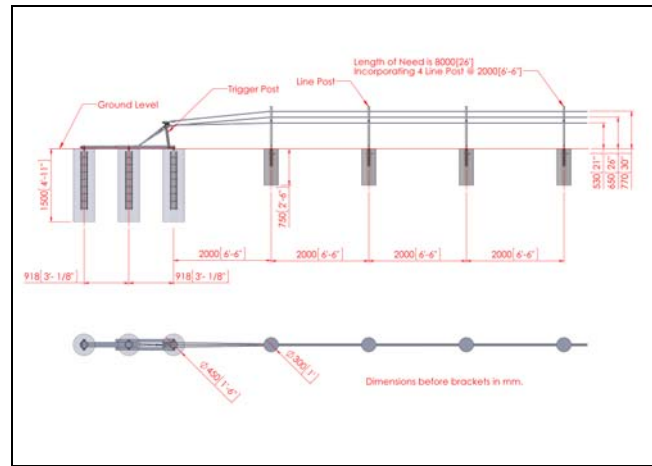

NU-TEN® TERMINAL END – Set-up (Option 2)

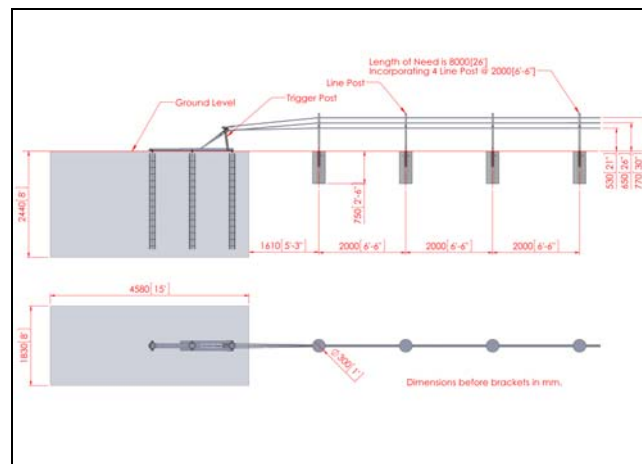

NU-TEN® TERMINAL END – Set-up (Option 3)

Nu-Cable®

Cable Barrier Systems

INSTALLATION MANUAL

SECTION I TERMINAL SYSTEM CHECKLIST

CONTENTS

INSTALLATION CHECKLISTS	2
Terminal/Anchor Checklist	2



It's Our Nature. 

INSTALLATION CHECKLISTS

Terminal/Anchor Checklist

- Is there soil erosion around the end anchor? Eroded or disturbed soil should be replaced and compacted.
- Was the L-bracket installed with the CRP Posts?
- Did the CRP foundation move after tensioning the cable?
- Is the embankment depth such that no more than 4" of the base of the CRP post is exposed above ground level?
- Has the soil strength been taken into consideration with respect to the depth of the foundations?
- Does the foundation design meet the requirements of the project specifications and/or drawings?
- Was the concrete 3,000 psi (25MPa) and cured for a minimum of (7) seven days prior to tensioning the system?

NU-TEN® TERMINAL END:

- Has the trigger post been installed at the correct angle in the system?

Nu-Cable®

Cable Barrier Systems

INSTALLATION MANUAL

SECTION J SYSTEM DELINEATION

CONTENTS

DELINEATION.....	2
POST CAPS.....	3



It's Our Nature. 

DELINEATION

System delineation is not typically supplied with the Nu-Cable® barrier system due to the wide variety of delineation specifications between states. Delineation should be installed as directed by the engineer.

The bonding surface must be relatively clean and dry. Contaminated surfaces should be cleaned with a 50-50 Isopropyl Alcohol and water mixture. Use a lint-free cloth. Substrate temperature must be above 50 degrees F for proper adhesion.

Primer should be shaken well before using. Apply a thin, uniform coating to the bonding surface using the minimum amount that will fully coat the surface. Allow to dry completely before applying tape.

Remove backing from pressure-sensitive reflective sheeting and apply pressure by rolling or rubbing to ensure good contact.

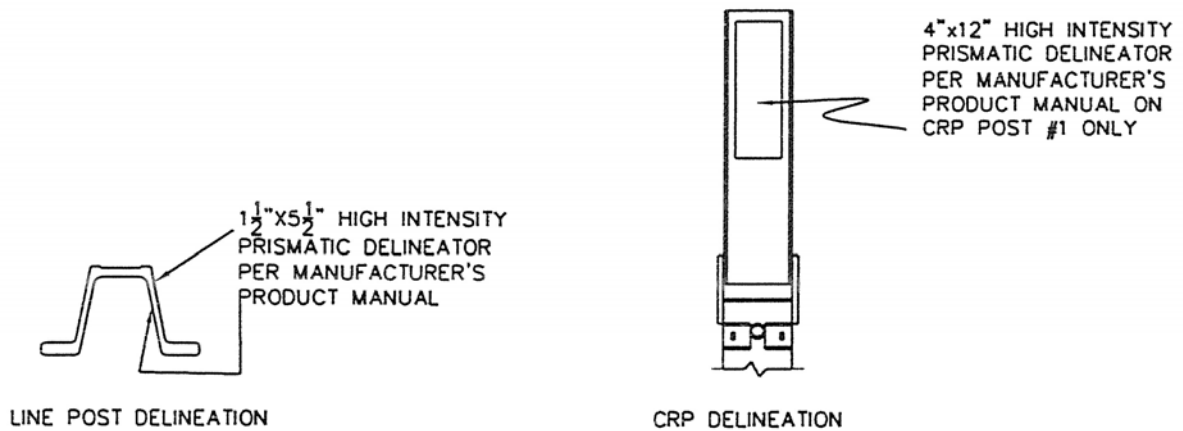

DELINEATION DETAILS

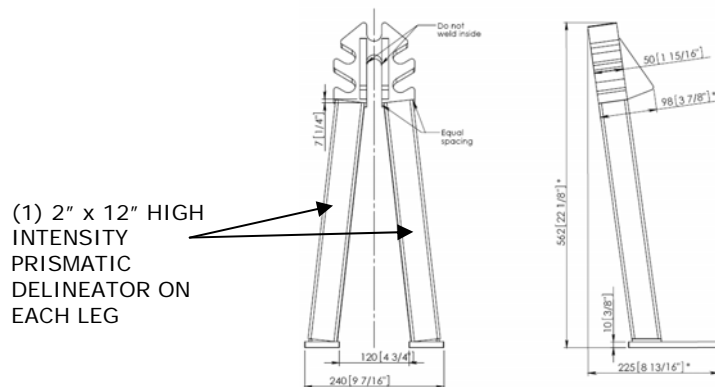

NU-TEN TRIGGER POST

POST CAPS

Optionally required based on project specifications.

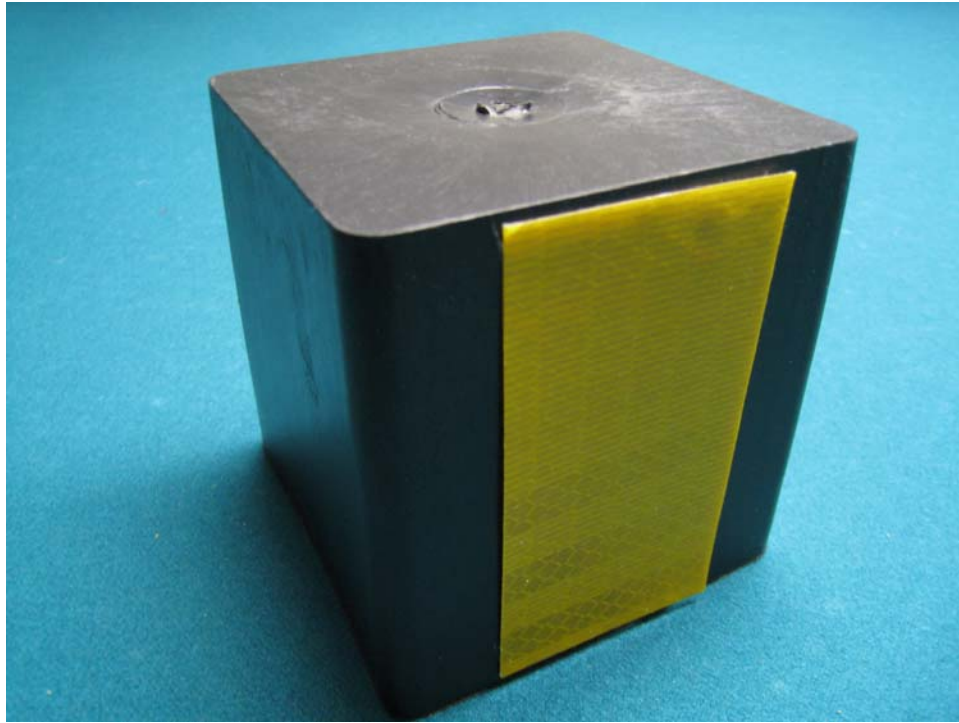

The Nu-Cable systems that only use hook bolts (TL3 – 3 or 4 cable for 6:1 slopes) have the line post firmly inside the center grooves of the cap.



The Nu-Cable systems that use hangers and straps (TL3 for 4:1 slopes or TL4 for 6:1 slopes) have the line post inserted all the way to the top of the cover utilizing the top grooves.



Adhesive is optional for securing the caps to the line posts.

Nu-Cable®

Cable Barrier Systems

INSTALLATION MANUAL

SECTION M
APPENDIX: TESTING SOIL CONDITIONS

CONTENTS

SOIL TESTING..... 2



It's Our Nature. 

SOIL TESTING

This section includes information relevant to determining the soil density & conditions at a specific location. The processes and steps listed here are referenced throughout the manual to determine installation modifications to the system foundations required in order to maintain performance in weak, or soft, soils.

CAUTION: The options shown below are examples of typical foundations for use in strong or weak soil conditions for illustrative purposes. They should not be assumed to be the only options available. If soil conditions at each location are unknown or do not meet the minimum requirements for strong or weak soil as outlined in Section M, a geotechnical review by a professional engineer shall be conducted prior to starting installation. The results of this evaluation shall determine foundation design at each location.

In order to verify site soil as a particular soil using a DCP (Dynamic Cone Penetrometer) or SV (Shear Vane), please reference the following table and instructions:

Cohesive Soils	
Description Su (kpa)	Foundation Pile Depth NU-TEN ANCHOR
51 - 100	450mm ø x 2500mm (18" ø x 96")
101 - 125	450mm ø x 1500mm (18" ø x 60")
Cohesionless Soils	
Description Phi (0)	Foundation Pile Depth
>30	450mm ø x 2500mm (18" ø x 96")

Table 1

- Purchase the DCP equipment.
- Purchase the ASTM publication ASTM STP 399 (available at the ASTM website) that describes the test procedure
- Submit that to the state or project engineer to make sure the tool is acceptable to them.
- The manual shows a curve that correlates the blow count from the DCP to a Standard Penetration Test (SPT) blow count. For native soil, a blow count of 15 (DCP) is equivalent to a Standard Penetration Testing (SPT) blow counts of 10 blows per foot.
- Once the SPT blow counts are known, we can use them to calculate the undrained shear strength (Su) of the cohesive soil as follows:
 - $Su \text{ (kPa)} = \text{Converted SPT blow count} \times 5$ this is the units included in the NU-TEN manual
 - Or
 - $Su \text{ (ksf)} = \text{Converted SPT blow count} / 10$
- If the blow count in the field is less than 15, then the foundations will have to be increased because the soil will not qualify as stiff.
- Need to make sure whoever runs the test out in the field is familiar with the procedure. It is very easy to make a mistake about procedure of using this particular tool. Whoever performs the test in the field will have to assume responsibility for the results.
- The test should be performed in one-foot intervals down to the design bottom elevation. We are interested in the strength of the soil above (at depths of 0, 6 inches, and 2 feet) the bottom elevation because this is the soil that will provide lateral resistance to the system. You cannot just drill the holes and check the bottom.

Nu-Cable®

Cable Barrier Systems

INSTALLATION MANUAL

SECTION N APPENDIX: REPAIR & MAINTENANCE

CONTENTS

REPAIR & MAINTENANCE	2
Repeat Impacts.....	2
Releasing Tension	3
Cutting Cables	3
Pavement Overlays or Resurfacing.....	4
Emergency Access.....	4
Materials for Maintenance.....	4



It's Our Nature. 

REPAIR & MAINTENANCE

The Nu-Cable® System, regardless of installation method, is very easy to repair after an impact. The longitudinal elements (the cables) of the barrier will rarely need to be replaced. Visually inspect the cables, and if necessary, use cable splices to replace damaged cable.

Damaged posts and hook bolts should be replaced.

In the case of driven posts, the damaged posts must be removed and ground repaired before driving a new post.

After a significant impact it is recommended to check the tension. Also, check tension if an impact occurs close to an end terminal.



The many factors contributing to increased deflections can, in some instances, lead to maintenance and performance issues. The Nu-Cable® High-Tension System is a low-maintenance cable barrier system. Checking the tension of the cables on an annual basis, or after a severe impact, should be adequate. If impacted, a slack cable will result in increased lateral deflections. If the slack allows for a cable to become incorrectly positioned, the propensity for vehicle under-riding may increase. After all impacts, the system requires inspection and replacement or repair of damaged parts.

Repeat Impacts

High-Tension Cable barrier systems have shown capabilities of withstanding additional vehicular impacts on a damaged barrier. Due to the high tension, the cables typically do not fall to the ground as is the case with low-tension cable systems.

Releasing Tension

In certain circumstances, it may be necessary to release the tension in the system. Those may include the need to perform a repair, or a vehicle has become entangled.

There are three common ways to release the tension in the system.

1. On a short run, in a non-emergency situation, the easiest method to release tension is to open several turnbuckles to their maximum length¹. This method allows the de-tensioning and the re-tensioning to be done with hand tools.
2. Using a cable grip and a vehicle of sufficient size, attach the cable grip to the longest end of the run not affected by the accident. Drive the vehicle towards the accident to release tension. A worker can then either take out a turnbuckle or cable splice, unscrew the terminal end connector from the CRP, or cut the cable.
3. Using a ratchet come-along (note capacity²) and two cable grips, pull the cable grips toward each other to release tension. Once tension is safely removed from the section of cable to repair, remove the nearest turnbuckle or cable splice, unscrew the terminal end connector from the CRP, or cut the cable.
4. In emergency situation, the CRPs can be longitudinally run over (slowly) with a truck. The CRPs will simply lay down and release the tension. The CRP posts can be reused. It will then be needed to replace the two 5/16" (8mm) breakaway bolts.



¹ Completely unscrewing the turnbuckle or cable anchor end, or unscrewing the cable splice at all, without first removing the tension can be unsafe. The cables will move rapidly when the threads strip out of the connection. This method is not recommended.

² Most construction come-alongs are only 2000# capacity. Capacity of come-along and cable grip must be equal or greater to the amount of tension in system. Typically 8000# to 12,000# capacity will be needed.

Cutting Cables

Although it can be done, cutting cables under tension should be done with caution. It is best to first release tension in the cables by using the turnbuckles if at all possible. A vehicle becoming entrapped in the system can create a higher-than-normal tension. In an emergency, the cables CAN be cut, by using great care, with an abrasive wheel saw. Make sure no one is near the cutting point upstream or downstream. If cutting near a turnbuckle, remove adjacent posts. Use gloves and safety goggles and cut very carefully. Pay particular attention when there are only a few strands left, at the final stage of cutting. In worst case, use a bolt cutter with long handles.



Pavement Overlays or Resurfacing

Cable heights are critical to performance of the system. If the roadway has experienced an overlay, ensure cable heights are correct, and that the slope to the barrier does not exceed the maximum allowed. For significant overlays, it may be necessary to install extra-height posts.

Where it is anticipated that future roadway construction will require increases in the roadway surface elevation, a pro-active solution is to install extra-height posts in the original installation to allow for vertical adjustment of the cables. This option is only available in Test Level 3 systems.

Emergency Access

A temporary crossover for emergency vehicles or temporary traffic control can be made at any location of the installed cable barrier by removal of the special locking hook bolts and/or cable hanger straps, thus allowing the cables to slacken. The number of posts necessary for removal depends on the tension and temperature, but normally 15-40 posts will be enough. The weight of the cable will provide enough slack for passing over with vehicles.

Materials for Maintenance

Your NUCOR distributor carries an inventory of replacement parts for the Nu-Cable® System to facilitate quick repair of an impacted system. In addition, we recommend that DOTs or maintenance authorities keep a minimum quantity of repair parts on hand.

A general rule of thumb is to stock 2% to 4% of the total project, rounded up to the minimum order quantities (below).

Line Posts	=	50 piece bundles
Small Hook Bolts	=	100 pieces
Large Hook Bolts	=	50 pieces
Cable Hanger & Retainer Strap	=	50 Bundles
CRP/Trigger posts	=	3 or 4 pairs
Turnbuckles	=	3 or 4 pairs
Cable Anchor Ends	=	3 or 4 pieces
Cable Spool	=	2000 ft.

Please contact your distributor for up to date pricing on products.

Nu-Cable[®]

Cable Barrier Systems

INSTALLATION MANUAL

SECTION P
APPENDIX: CONTACT INFORMATION

CONTENTS

TECHNICAL SUPPORT AND SALES	2
DISTRIBUTORS.....	ERROR! BOOKMARK NOT DEFINED.



It's Our Nature. 

TECHNICAL SUPPORT & SALES

Manufacturer:

NUCOR Steel Marion, Inc.
www.nucorhighway.com

Corporate Headquarters

Steve Conway
District Sales Manager
(800) 333-4011 ext. 260
Steve.Conway@nucor.com
Mailing Address:
912 Cheney Ave.
Marion, OH 43301

Manufacturer Representatives

Mark Fellows
District Sales Manager
(740) 321-1273
Mark.Fellows@nucor.com
Mailing Address:
912 Cheney Ave.
Marion, OH 43301

Joe Frazzetta
Product Specialist
(636) 519-1305
Joe.Frazzetta@nucor.com
Mailing Address:
912 Cheney Ave.
Marion, OH 43301

Chris Sanders
Inside Sales Representative
(740) 383-9637
Chris.Sanders@nucor.com
Mailing Address:
912 Cheney Ave.
Marion, OH 43301