



Structural & Steel Products, Inc.

**LOWERING
DEVICES**

How do we make a difference? That was the guiding question as Stratus Products began operations in early 2007. The answer came from the same formula that has made Structural & Steel Products, Inc. a success since 1969.

Our basic formula is to hire talented people within the industry, that have years of proven and respected experience. Next, we encouraged a freethinking attitude among our staff whose ideas and variety of strengths combine and complement to create a world class product. Then, we used the corporation's ability to bring a multitude of diverse business operations together to assure high quality products and maintain efficient production capabilities.

Over the years, this formula and business philosophy have been proven by the test of time, through Structural and Steel Products success and growth. These key ingredients also help to ensure success for the Stratus Products brand. Since its inception, the Stratus Products group has continued to meet and exceed the demands of engineering. We have produced the highest quality and reliable products that the industry has to offer.

By continuing to focus on the customer's needs, Stratus Products is able to produce high-end components and operate successfully. Our experts in engineering, operations, and marketing, work together from conception to installation to meet and exceed your professional requirement expectations. We assign the utmost importance to searching for creative solutions that help reduce costs and improve our product.

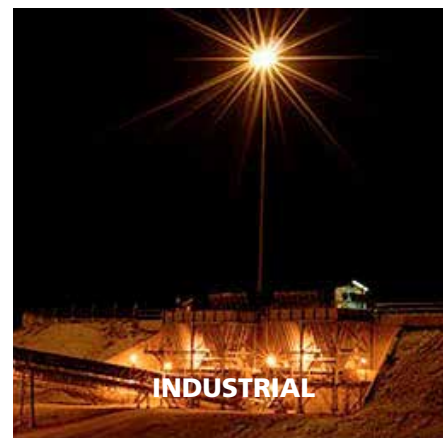
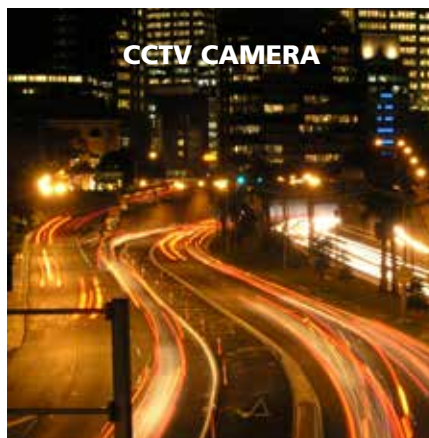
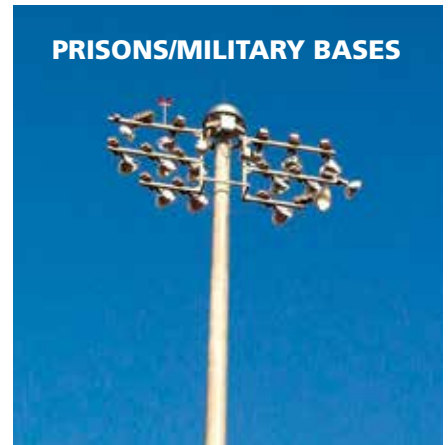

"Deviat an inch. Lose a thousand miles."

Chinese Proverb

Everyone understands the importance of an inch. And at Stratus Products we know just how important an inch can count. That's what motivated Stratus engineers to design the most forgiving, user friendly top latch lowering system on the market.

Where the competitors provide fractions of inches we designed a system that gives you **SIX**.

Six inches of operational leveling flexibility between the head frame and the ring platform. If it is within six inches it's good to go. Latch-Unlatch, Latch-Unlatch, Latch-Unlatch, Latch-Unlatch...First time, every time.

Don't believe it? See for yourself. Check out our demonstration video on our website, www.s-steel.com or YouTube. Go ahead, all you have to do is move your mouse a few inches.

Tired of systems that "hang" when the latching system is out of sequence?

Tired of adjusting hoist cables like you were building a Swiss watch?

Tired of renting cranes?

See our 6 inch operational leveling flexibility video on our website or on YouTube. Search for "Stratus LD Demo"



STRATUS TOP LATCH LOWERING DEVICE SYSTEM

Six inches of operational leveling flexibility between the head frame and the ring platform.



STRATUS PRODUCT CATALOGS

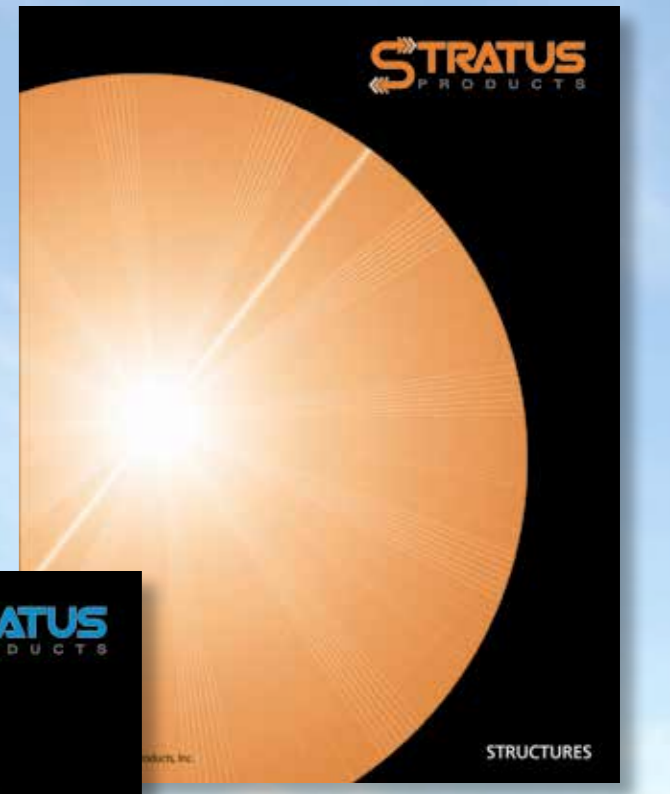

CONTACT STRATUS FOR YOUR CATALOG

1320 South University
Suite 701
Fort Worth, Texas 76107

1.800.782.5804 Toll free

www.s-steel.com



EXAMPLE

1060 - 1 - 08 - HM - 100H - 480 - L - 100 - D - AR1

MODEL	CIRCUITS	FIXTURE QUANTITY	FIXTURE TYPE	LAMP TYPE	FIXTURE VOLTAGE	ELECTRICAL SERVICE	POLE HEIGHT	CABLE SYSTEM	OPTIONS
1	2	3	4	5	6	7	8	9	10

1 MODEL

1060 = Top Latching External Drive Motor
 1070 = Top Latching Internal Drive Motor
 2060 = Bottom Latching External Drive Motor
 2070 = Bottom Latching Internal Drive Motor
 3060 = StratuSport Top Latching External Drive Motor
 3070 = StratuSport Top Latching Internal Drive Motor
 1080 = Top Latching External Winch System

2 CIRCUITS

01 = Single Circuit 02 = Two Circuit
 03 = Three Circuits 04 = Four Circuits

3 FIXTURE QUANTITY (TOTAL)

01 = One Fixture 02 = Two Fixtures
 03 = Three Fixtures 04 = Four Fixtures

4 FIXTURE TYPE

FL = Flood Lighting HM = High Mast Lighting
 SP = Sports Lighting OT = Other (Explain)

5 LAMP TYPE

40H = 400 Watt High Pressure Sodium
 40M = 400 Watt Metal Halide
 40R = 400 Watt High Pressure Sodium w/Magnetic Regulated Ballast
 75H = 750 Watt High Pressure Sodium
 100H = 1,000 Watt High Pressure Sodium
 100M = 1,000 Watt Metal Halide
 150M = 1,500 Watt Metal Halide
 165M = 1,650 Watt Metal Halide
 200M = 2,000 Watt Metal Halide
 300L = LED 30,000 Lumen
 500L = LED 50,000 Lumen
 ETC...
 XXXL = LED (Other Lumen)

6 FIXTURE VOLTAGE

120 = 120 Volt 208 = 208 Volt
 240 = 240 Volt 277 = 277 Volt
 347 = 347 Volt 480 = 480 Volt

7 ELECTRICAL SERVICE (POLE BASE)

A = 120-V 1-PH 3-Wire H = 277-V 1-PH 3-Wire
 B = 120/240-V 3-PH 5-Wire J = 277/480-V 3-PH 5-Wire
 C = 208-V 1-PH 3-Wire K = 480-V 1-PH 3-Wire
 D = 208-V 3-PH 4-Wire L = 480-V 3-PH 4-Wire
 E = 240-V 1-PH 3-Wire M = 347-V 1-PH 3-Wire
 F = 120/240-V 1-PH 4-Wire N = 347/600-V 3-PH 5-Wire
 G = 240/480-V 1-PH 4-Wire X = Other Special Explain

8 POLE STRUCTURE HEIGHT

050 = 50-ft 10M = 10 Meters
 060 = 60-ft 20M = 20 Meters
 Etc = As Required Etc = As Required

9 CABLE SYSTEMS (WIRE ROPE) • H-HOIST W-WINCH

A = Galvanized 3/16" -H and 1/4" -W
 B = Galvanized 1/4" -H and 5/16" -W
 C = Galvanized 3/16" -H and 5/16" -W
 D = Stainless Steel 3/16" -H and 1/4" -W ("Standard")
 E = Stainless Steel 1/4" -H and 5/16" -W
 F = Stainless Steel 3/16" -H and 5/16" -W
 G = Galvanized 3/16" -H (1/4" -W on External Winch System)
 H = Stainless Steel 3/16" -H (1/4" -W on External Winch System)
 J = Galvanized 1/4" -H (5/16" -W on External Winch System)
 K = Stainless Steel 1/4" -H (5/16" -W on External Winch System)

10 OPTIONS

LR = Lightning Rod (24" standard)
 LAR = Lightning Arrestor Ring Mounted
 LAC = Lightning Arrestor On Circuit Breaker
 AR1 = Aircraft Warning Light Single STD (incandescent)
 AR2 = Aircraft Warning Light dual STD
 AR3 = Aircraft Warning Light dual STD w/transfer relay
 AR4 = Aircraft Warning Light single LED
 AR5 = Aircraft Warning Light dual LED
 AR6 = Aircraft Warning Light dual LED w/transfer relay
 RPC = Ring Mounted Photo Control
 WCG = Winch Cable Guard
 HSS = Hoist Sheaves Stainless Steel (aluminum standard)
 HZP = Hoist Sleeves, Plated Steel
 SST = Cable Transition, Stainless Steel (galvanized standard)
 SSW = Stainless Steel Weldments, Head Frame - Ring Platform -
 Mount Arm - Cable Transition (galvanized standard)
 SLP = Slip Fitter
 CCTV = Closed Caption Television Option
 ENC = Enclosed Luminaire Ring (wireway)

2.7 EPA / 550 Lbs (less fixtures)

Minimum Top Diameter = 4.625 I.D.
 All System Models

Minimum Base Diameter = 16.5" I.D.
 Externally Driven Systems

Minimum Base Diameter = 18.625" I.D.
 Internally Driven Systems

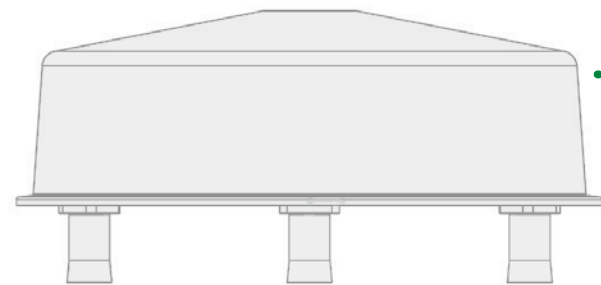

Head Frame

Our **top latching system** is the best in the industry. The mechanism possesses the most advanced and reliable cam-to-shaft latching action. Each component is investment cast from high quality stainless steel materials that conform to ASTM A743-CF8M specifications (i.e. 316). The parts are heat treated and bead blasted to ensure superior function.

The cam incorporates a skirting-bell shape to reduce exposure of the cam teeth to rain, sleet or snow. The latch shaft incorporates an automated plumb-line design along with a tool-less integral flag attachment system.

What does this mean to you? It means that our ring can be out of level, in relation to the head-frame, by as much as **SIX INCHES** and yet still properly latch and unlatch in sequence.

Check us out on YouTube ("Stratus LD Demo")

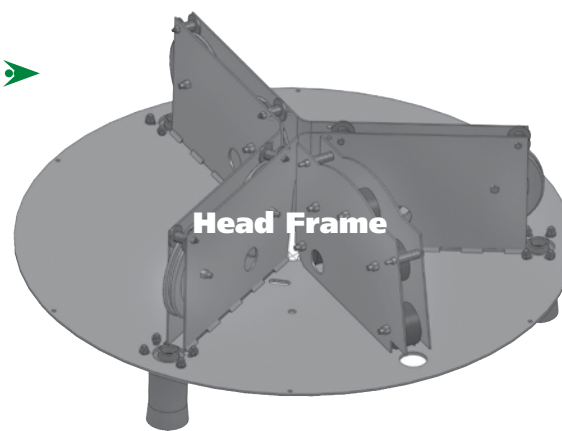

Head Frame

Stratus Products **head frame assembly** is the most rigidly built and stable platform found in the industry. And with this stability comes uncompromised repeatability of the mechanical operation.

Our head-frame assembly features a triad frame weldment that includes the tallest gussets. These gussets frame the industries largest standard sheave diameters that conform to standard wire rope specifications for hoisting applications.

Our standard **power cord rollers** are made of non-conductive polymers and are arranged on a 15" diameter (7.5" arc). The rollers are also shaped to eliminate power cord roll or twisting and thus prevent the wire ropes and power cord from binding inside the pole.

The **top latching ring platform** assembly is stable and adaptive to multiple applications. The base component is a ring formed from a single piece of steel. The "C" (double flange) profile provides strength and simplicity while making it easily adaptable to various fixture configurations.

The stainless steel **latch shaft** is designed for strength, durability and simplicity. It works with the cam unit to self-align every time. This feature increases the ring platform's ability to properly latch, even while not being exactly level or square to the head frame. In fact it has been tested to latch even as the ring platform was out of level by **SIX INCHES!** (search YouTube.com for "Stratus LD Demo" to see it in action)

Three **centering arms** are spring loaded. They work to keep the ring concentric to the pole shaft during operation. This protects the lamps or other equipment from shock that could otherwise cause premature failure.

Three highly reflective indicator flags let the operator know when a system is in a safely latched and secured condition or if it is not latched and ready to be lowered for service.

Flexibility is what we kept in mind for the design of the **winch plate assembly**. Whether your system is **internal** or **external** drive, the installation method is the same. This approach allowed us to standardize the mount plate inside the pole, thus minimizing the chances for field issues.

The **winch** is a time tested and proven component. Our supplier is a leader in the industry for winches utilized in lowering device systems. The standard winch provides 30:1 gear reduction, self braking (to prevent "free spools") and a 5:1 factor of safety.

Three standard **circuit breaker enclosures** are NEMA 3R rated and accommodate a wide range of electrical configurations. As a solution based provider, we will also work with you to address any specialized application.

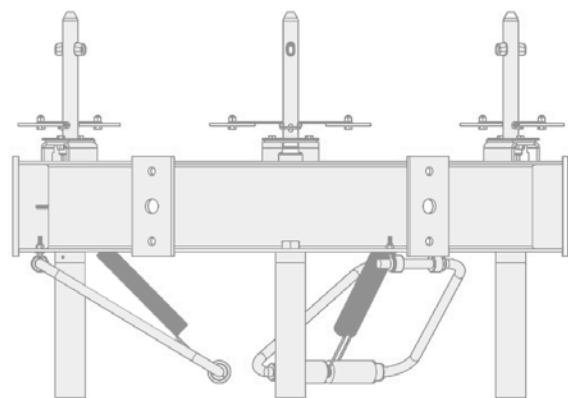

Ring Platform

When it comes to our **compression spring**, we decided that bigger was definitely better. Our spring action provides up to 5-times the normal travel than that of our competitors. And since it is housed inside of an aluminum tube, it is assured to travel straight and compress evenly. This means it works as intended through the entire travel length.

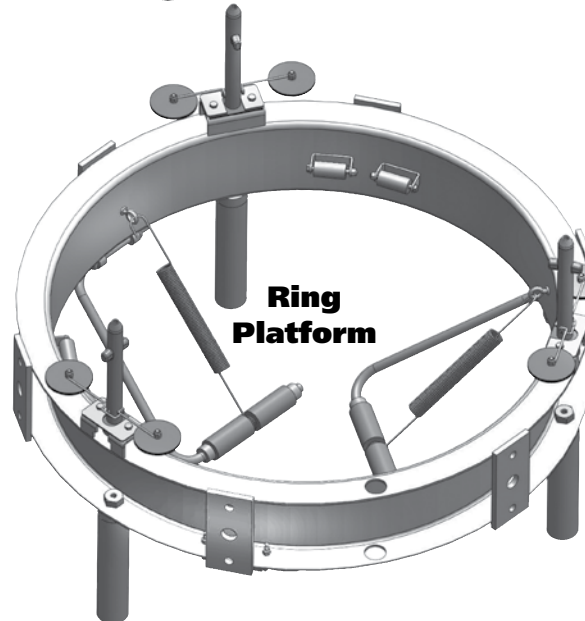

Ring Platform



Transition Assembly

Arguably, the **transition assembly** is one of the most critical elements of any properly functioning system. The Stratus Products assembly is specially designed to eliminate the conditions that normally cause twisting in the wire ropes. We believe our transition assembly to be the most efficient at making the 3 ropes to 1 rope transition.

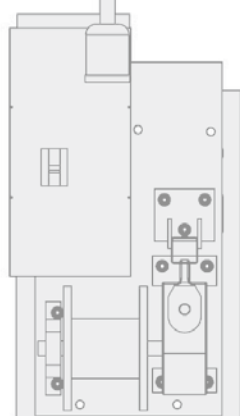
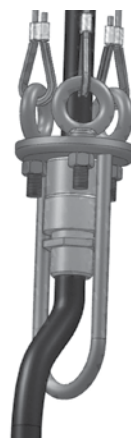

Winch Plate



Portable Drive Unit

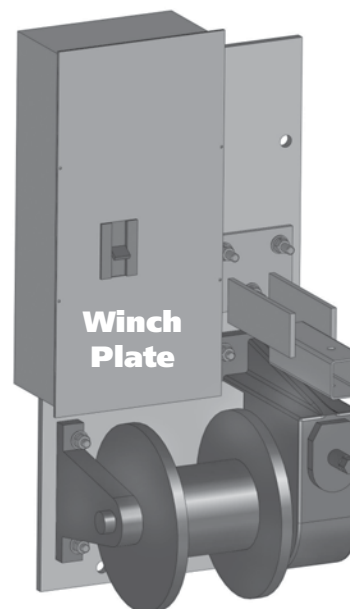

Winch Plate

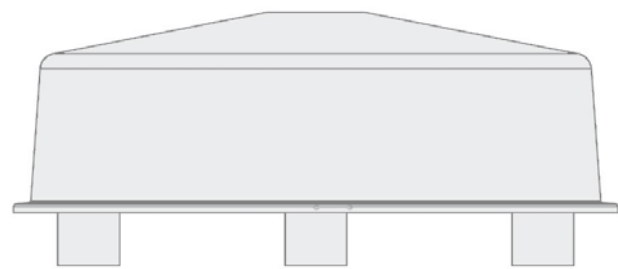

Head Frame



The bottom latching system incorporates an aluminum **guide block** that is precision machined with an internal bevel. This allows the system to easily center and prevents major fixture jolts during operation.

The **guide shaft** is long enough to adapt to changes in wire rope length, pole assembly length (due to settling) and or variances in latching. This length ensures that the shaft and guide block remain engaged.

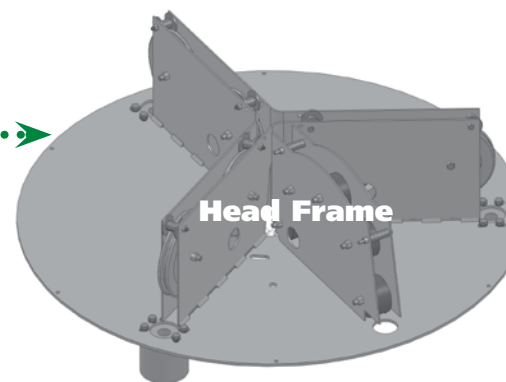

Head Frame

Stratus Products **head frame assembly** is the most rigidly built and stable platform found in the industry. And with this stability comes uncompromised repeatability of the mechanical operation.

Our head-frame assembly features a triad frame weldment that includes the tallest gussets. These gussets frame the industries largest standard sheave diameters that conform to standard wire rope specifications for hoisting applications.

Our standard **power cord rollers** are made of non-conductive polymers and are arranged on a 15" diameter (7.5" arc). The rollers are also shaped to eliminate power cord roll or twisting and thus prevent the wire ropes and power cord from binding inside the pole.

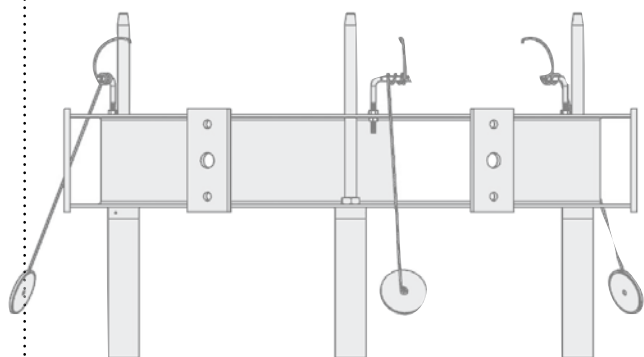

Ring Platform

When it comes to our **compression spring**, we decided that bigger was definitely better. Our spring action provides up to 5-times the normal travel than that of our competitors. And since it is housed inside of an aluminum tube, it is assured to travel straight and compress evenly. This means it works as intended through the entire travel length.

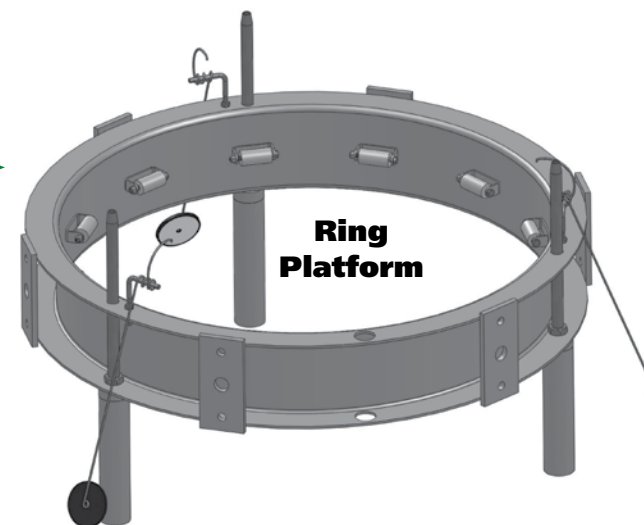

Ring Platform

The **bottom latching ring platform** assembly is stable and adaptive to multiple applications. The base component is a ring formed from a single piece of steel. The "C" (double flange) profile provides strength and simplicity while making it easily adaptable to various fixture configurations.

The ring is lined with **bump rollers** that protect the pole shaft and enhance the raising and lowering operation. At the customers option centering spring arms can be added.

Three highly reflective **indicator flags** let the operator know when the ring platform is properly seated with the head-frame. This assures that the latch chains are installed while the ring is at the correct elevation.

Transition Assembly

Arguably, the **transition assembly** is one of the most critical elements of any properly functioning system. The Stratus Products assembly is specially designed to eliminate the conditions that normally cause twisting in the wire ropes. We believe our transition assembly to be the most efficient at making the 3 ropes to 1 rope transition.

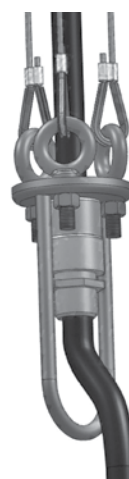

Winch Plate

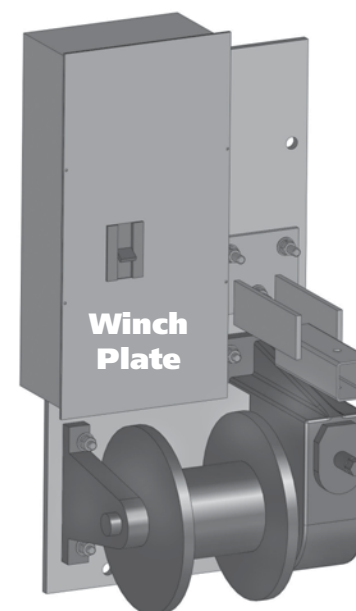
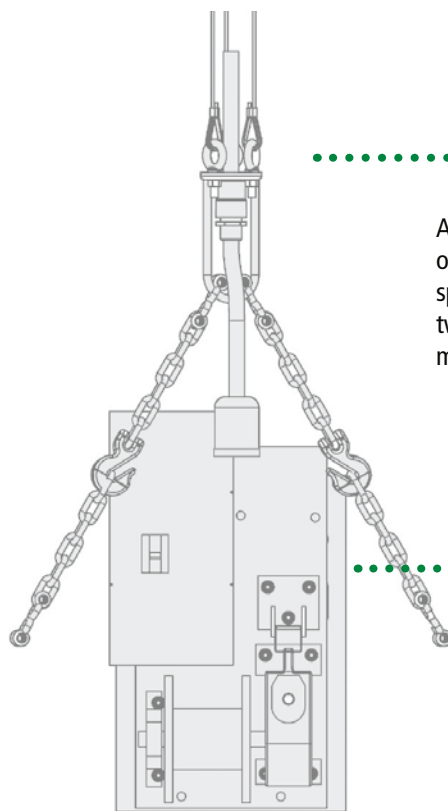

Winch Plate

Flexibility is what we kept in mind for the design of the **winch plate assembly**. Whether your system is **internal** or **external** drive, the installation method is the same. This approach allowed us to standardize the mount plate inside the pole, thus minimizing the chances for field issues.

The **winch** is a time tested and proven component. Our supplier is a leader in the industry for winches utilized in lowering device systems. The standard winch provides 30:1 gear reduction, self braking (to prevent "free spools") and a 5:1 factor of safety.

Three standard **circuit breaker enclosures** are NEMA 3R rated and accommodate a wide range of electrical configurations. As a solution based provider, we will also work with you to address any specialized application.



Portable Drive Unit

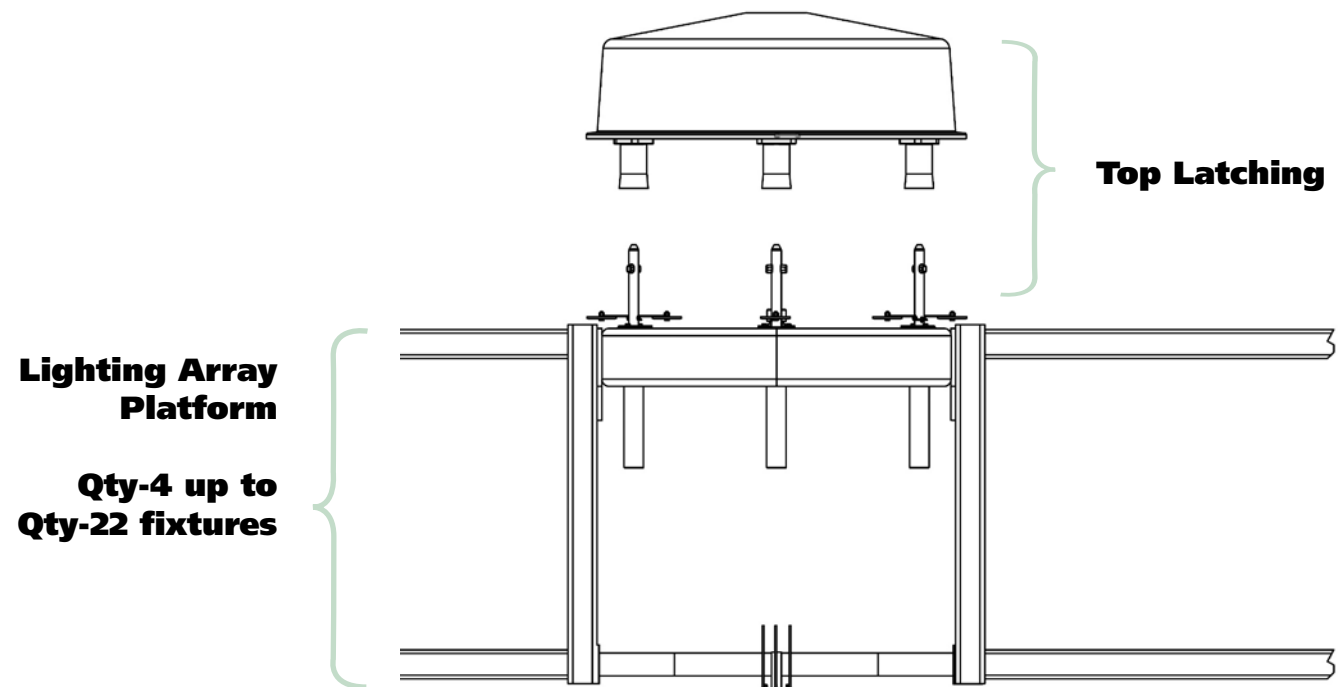

Either External Drive (3060) or Internal Drive (3070) Systems

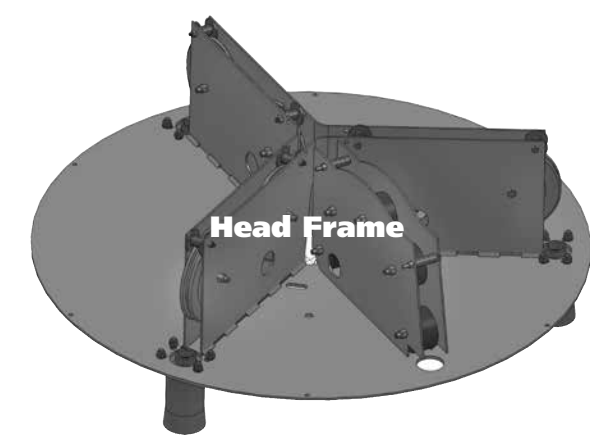
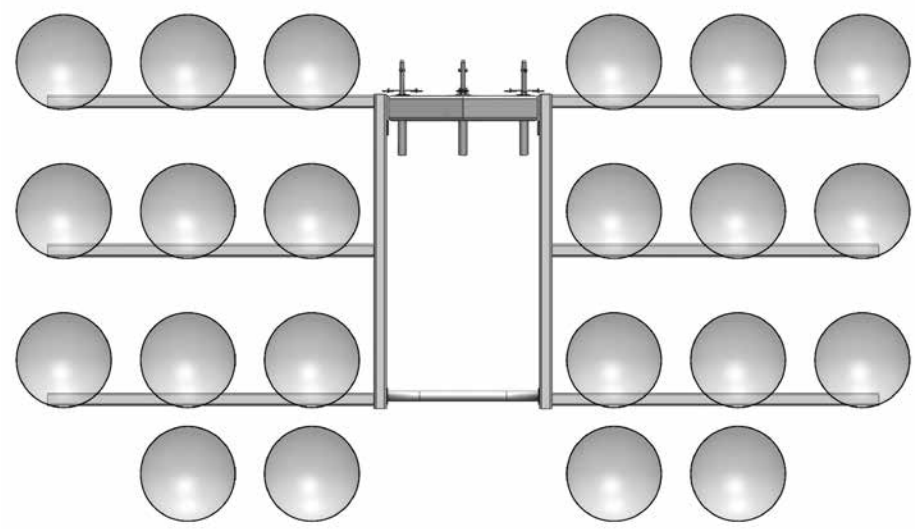
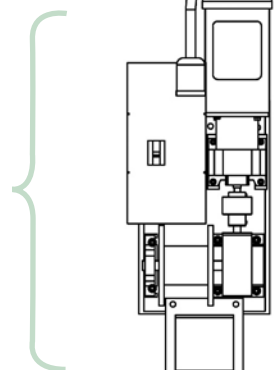

Stratus Products **head frame assembly** is the most rigidly built and stable platform found in the industry. And with this stability comes uncompromised repeatability of the mechanical operation.

Our head-frame assembly features a triad frame weldment that includes the tallest gussets. These gussets frame the industries largest standard sheave diameters that conform to standard wire rope specifications for hoisting applications.

Our standard **power cord rollers** are made of non-conductive polymers and are arranged on a 15" diameter (7.5" arc). The rollers are also shaped to eliminate power cord roll or twisting and thus prevent the wire ropes and power cord from binding inside the pole.

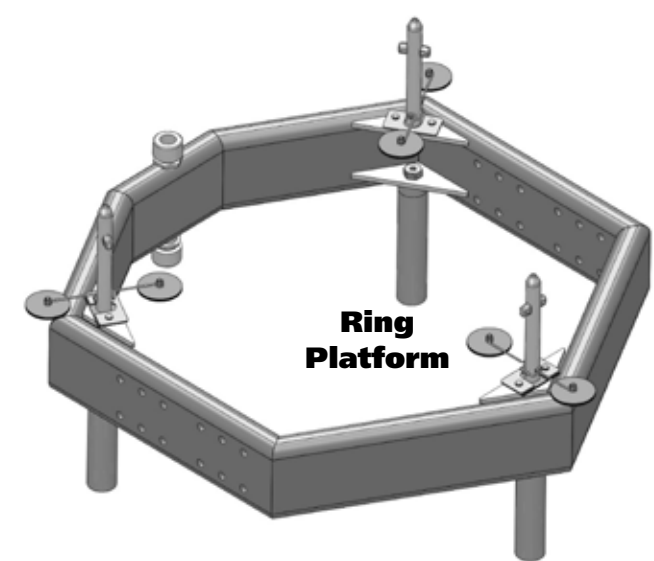

The **Stratusport** ring platform is the primary platform for systems that require a "rectangular" fixture array (that is all lights generally face one direction). This ring operates in the same manner as the standard ring platform except that it is structurally designed to support a maximum of 22 light fixtures and will generally be used only for systems that require more than 8 fixtures.

The stainless steel **latch shaft** is designed for strength, durability and simplicity. It works with the cam unit to self-align every time. This feature increases the ring platform's ability to properly latch, even while not being exactly level or square to the head frame. In fact it has been tested to latch even as the ring platform was out of level by **SIX INCHES!** (search YouTube for "Stratus LD Demo" to see it in action)

Three centering arms are spring loaded. They work to keep the ring concentric to the pole shaft during operation. This protects the lamps or other equipment from shock that could otherwise cause premature failure.

Three highly reflective indicator flags let the operator know when a system is in a safely latched and secured condition or if it is not latched and ready to be lowered for service.

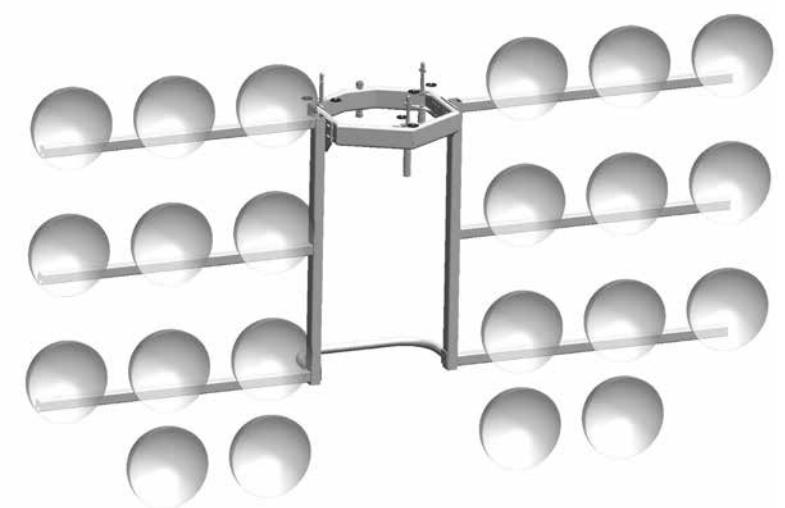

Internal drive systems are typically utilized for those projects where maintenance convenience is a premium value to the customer. Another consideration for the internal system is the dead load to be lifted as the internal system provides a more robust drive unit than that of the external drive.

The standard heavy lift system incorporates a 240 volt / 1.5-horsepower motor. This motor drives an 8:1 gear reducer. The gear reducer is coupled to the standard winch via a factory set torque clutch. Due to varying power provisions, the internal drive system can incorporate a step down transformer that is also installed inside the pole. By having these components installed at each pole, it allows maintenance personnel to more quickly and easily operate each unit.



External drive systems are more cost effective than an internal drive system while providing maintenance convenience. External drives are common for units that require no more than 12 fixtures (dead-load). External drive systems are designed to utilize the portable drive unit (PDU).

The standard external drive system is designed to work with a **Portable Drive Unit (PDU)**. The portable drive unit incorporates a 120 volt /1-horsepower motor, variable angle drive shaft and a factory set torque clutch. It is designed to typically lift a maximum of 12 light fixtures.

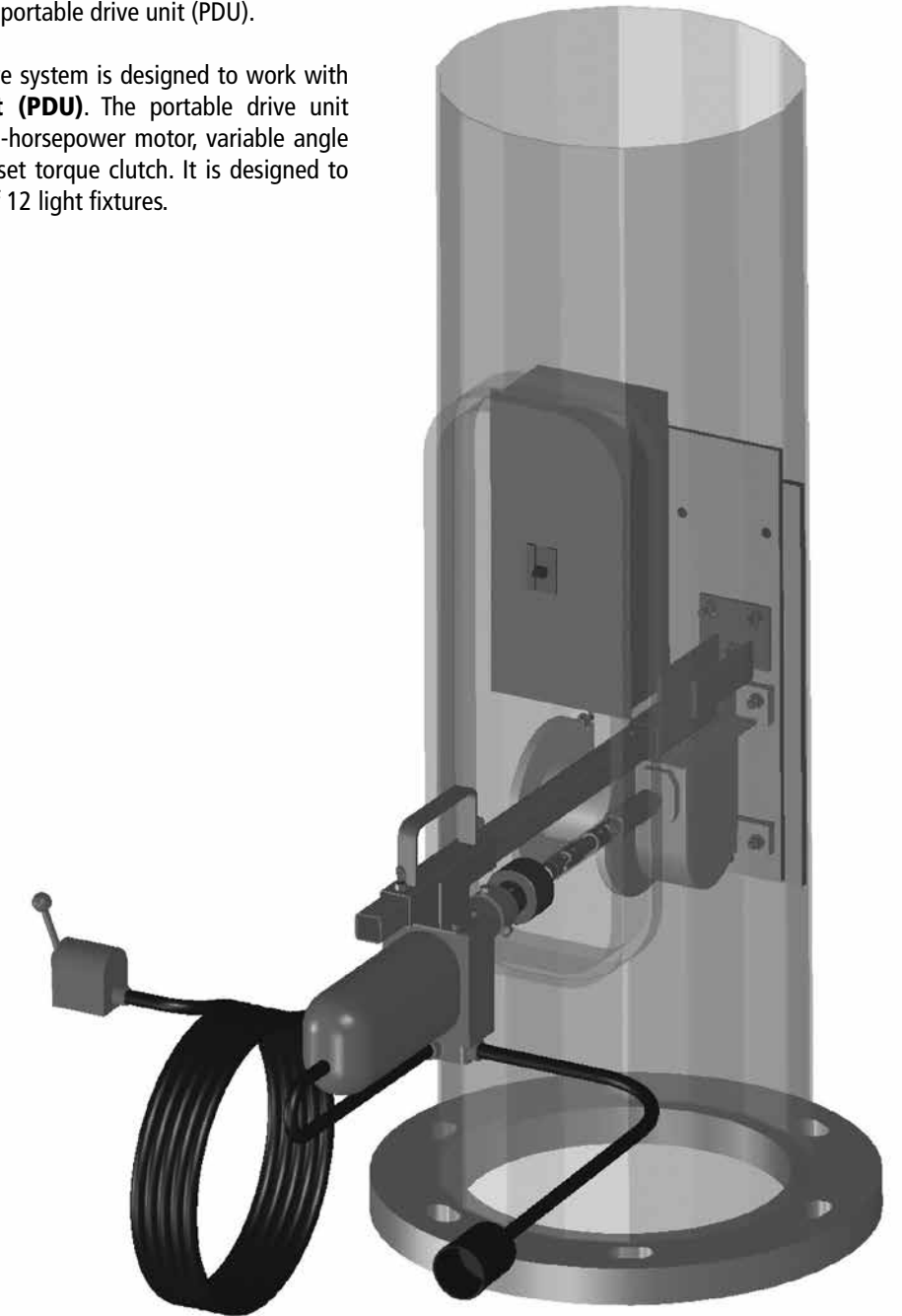

The **portable winch system** provides the most cost effective option of the 3 drive systems. It is a viable option for unique environments or shorter pole heights. By making the winch assembly portable, multiple poles can be serviced with only one winch. With the winch outside of the pole there is also the option of utilizing poles with smaller base diameters. The typical application for this system has poles up to 70 ft and a maximum of 8 light fixtures.

The standard portable winch system is designed to work with a **Portable Winch Unit (PWU)**. The PWU consists of a mount plate, winch and hitch tube. A standard portable drive unit is used as the drive for this system.

Inside the pole, a sheave provides a 90 degree transition for the winch cable while a breaker enclosure provides electrical service provisions. An over-size hand-hole provides easy access to all internal components.

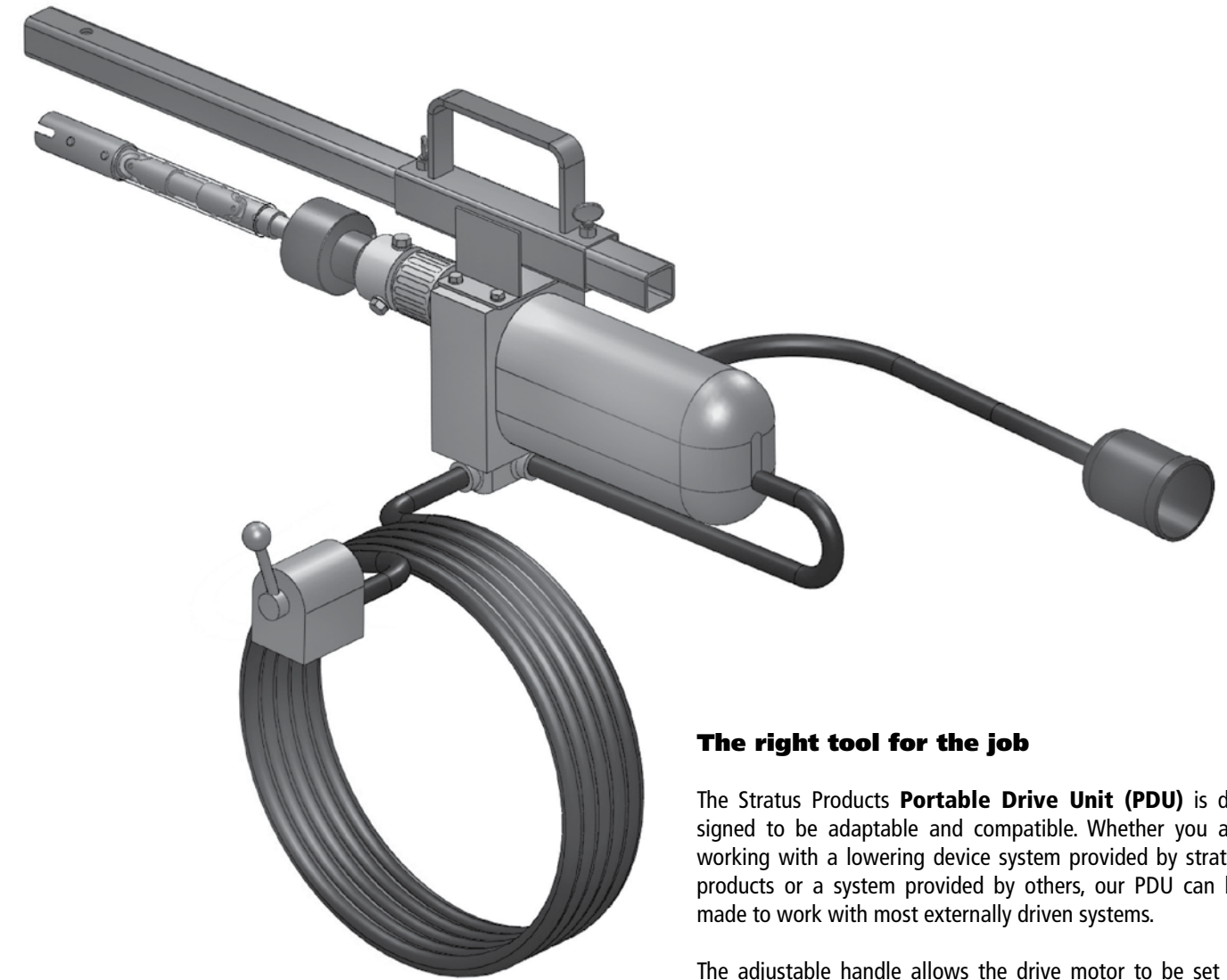
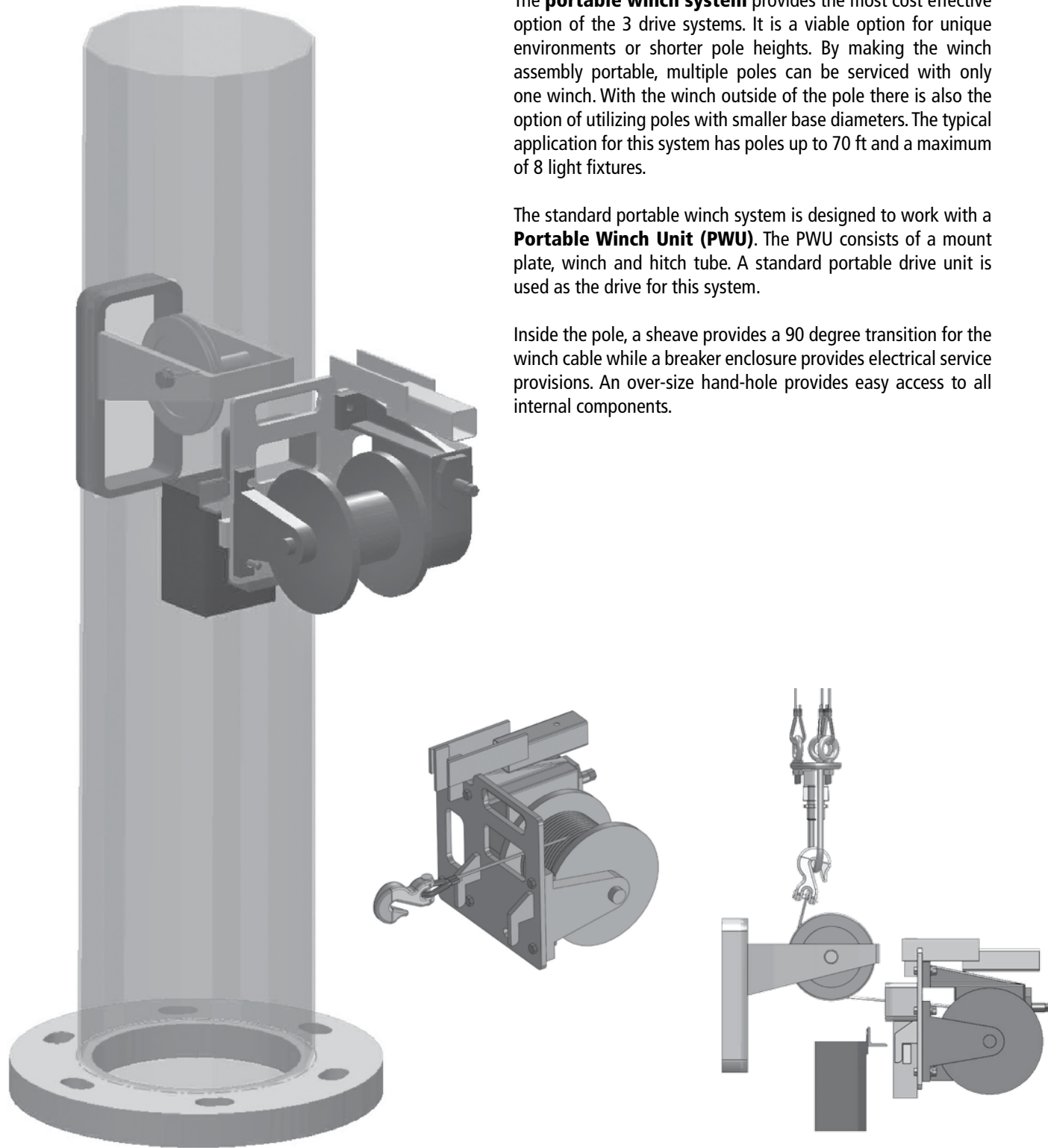

The right tool for the job

The Stratus Products **Portable Drive Unit (PDU)** is designed to be adaptable and compatible. Whether you are working with a lowering device system provided by stratus products or a system provided by others, our PDU can be made to work with most externally driven systems.

The adjustable handle allows the drive motor to be set at varying depths relative to the winch (up to 6"). A drive shaft with dual u-joints adapts to varying drive to winch alignments (up to 3").

The PDU is equipped with a 120 volt/1-horsepower motor. To protect the lowering device system, it is also equipped with a factory set torque clutch. A 25 ft cord, with forward and reverse drum switch, allows the operator to stand away from the pole while conducting the lift/lower operations.

TOP LATCHING EXTERNAL DRIVE **1060**

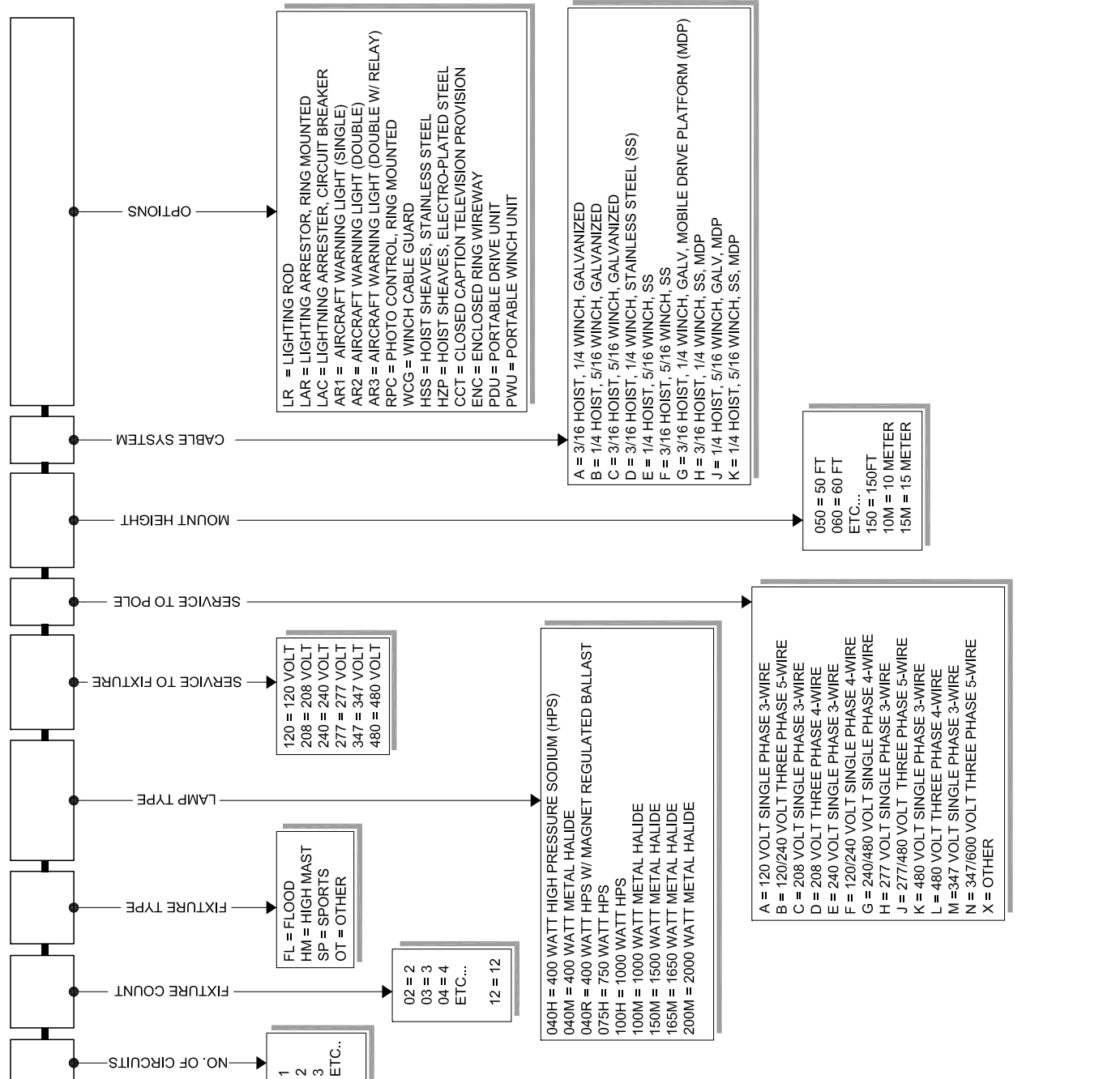
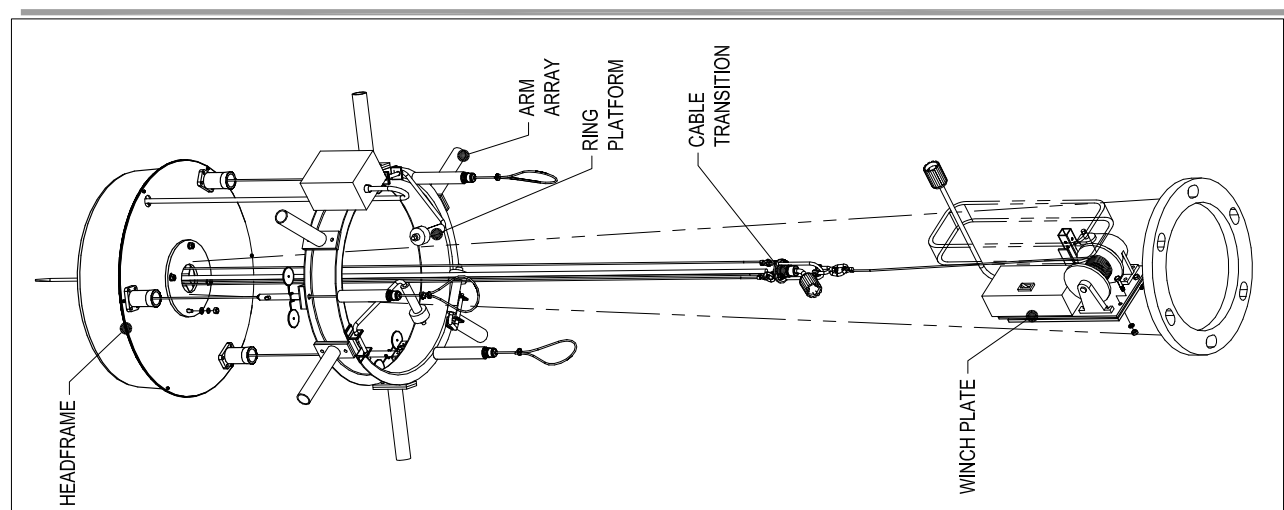

TOP LATCHING INTERNAL DRIVE **1070**

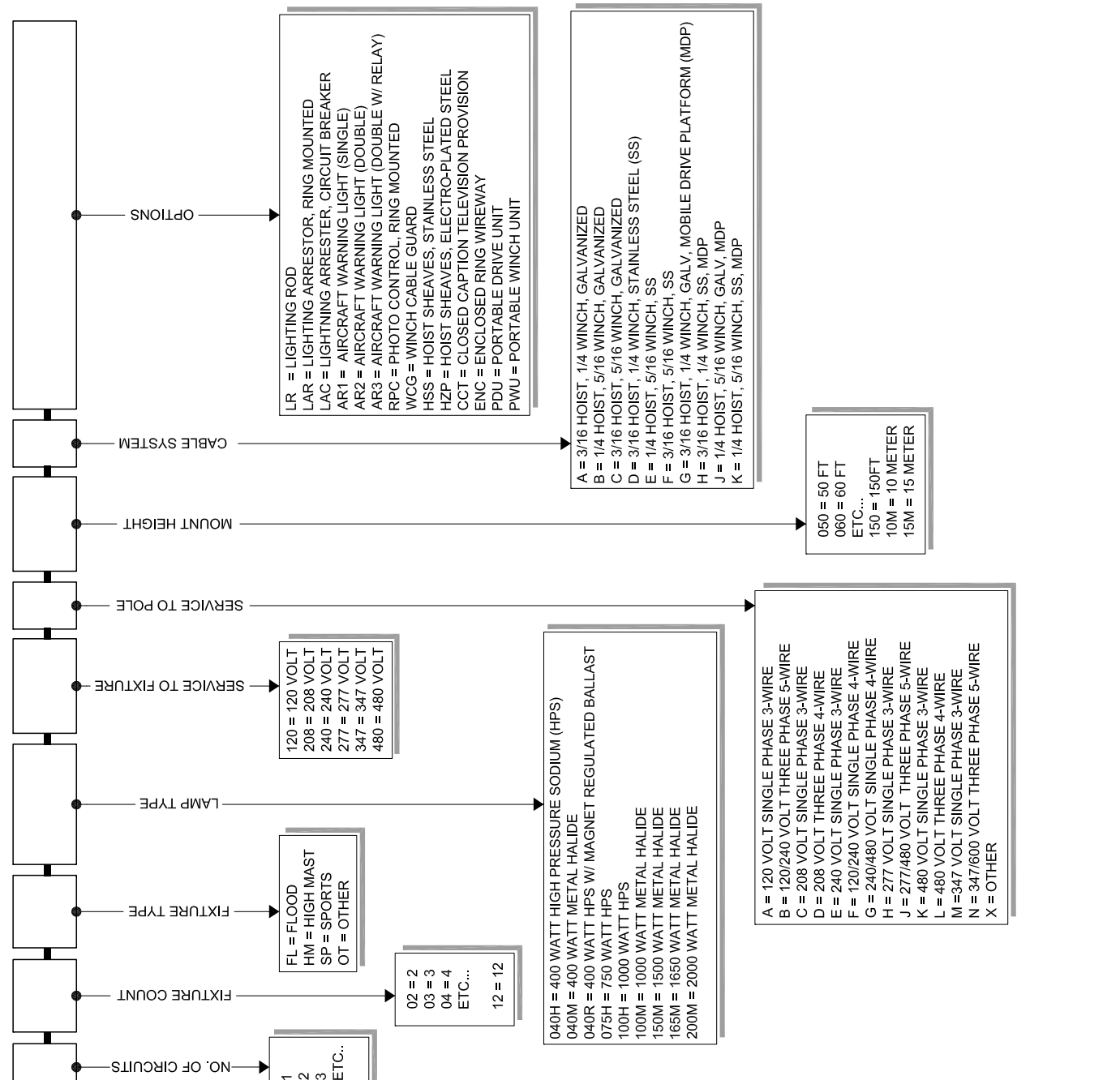
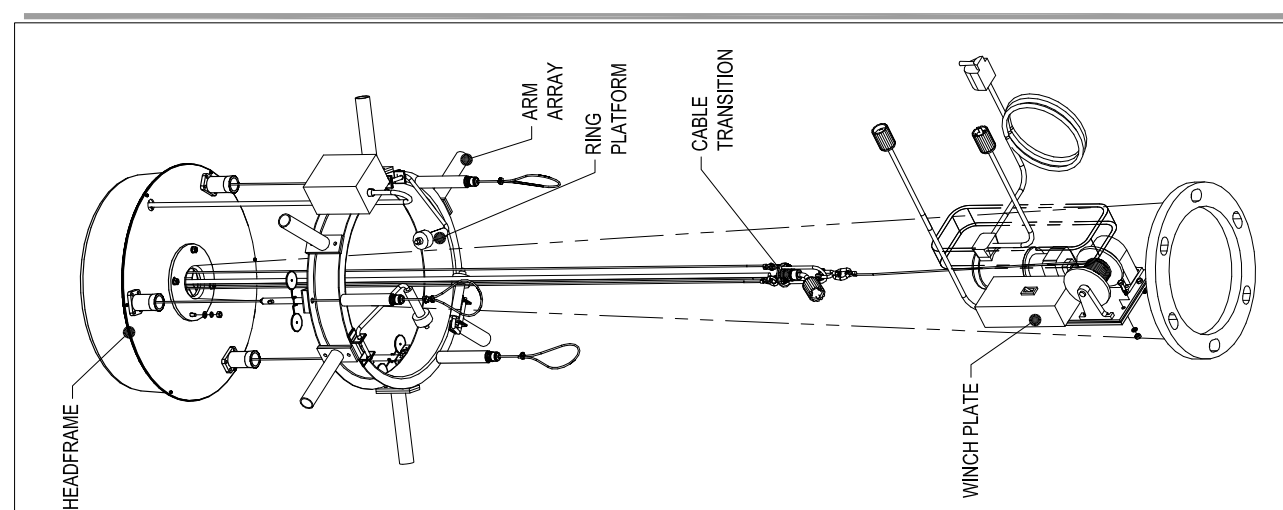

BOTTOM LATCHING EXTERNAL DRIVE **2060**

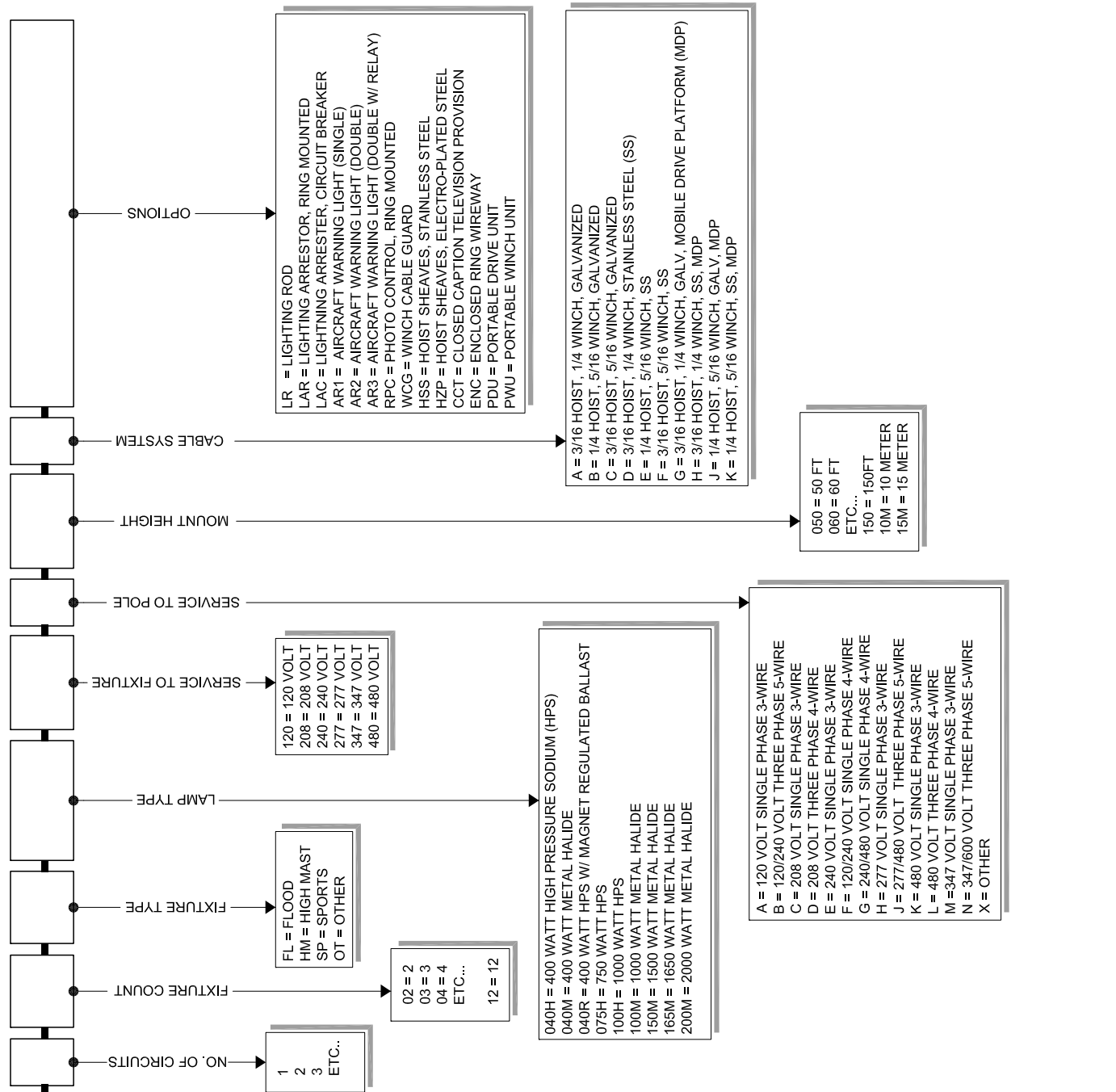
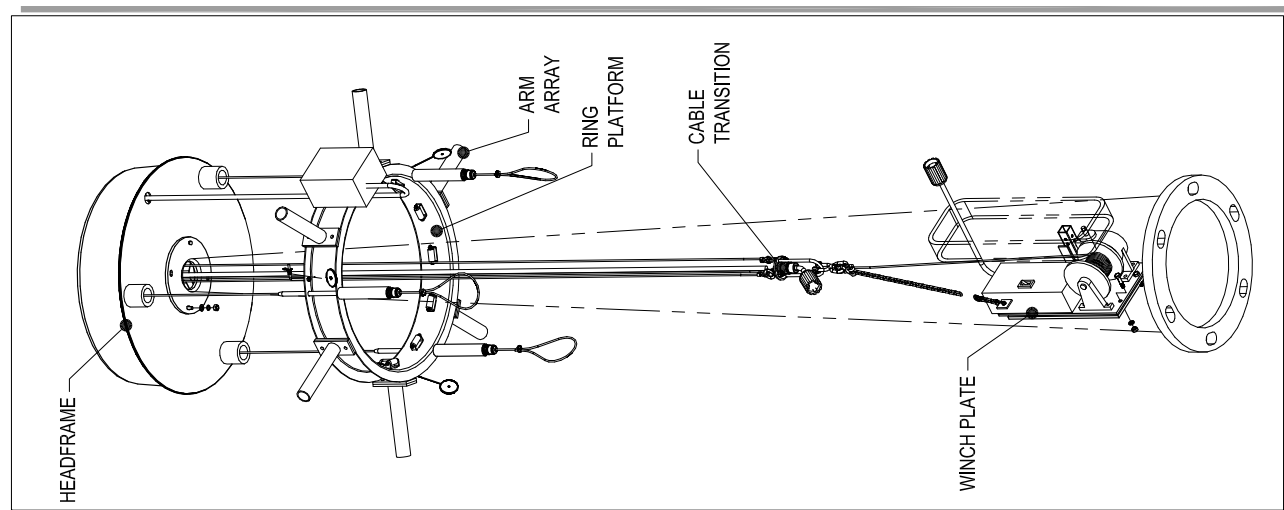

BOTTOM LATCHING INTERNAL DRIVE **2070**

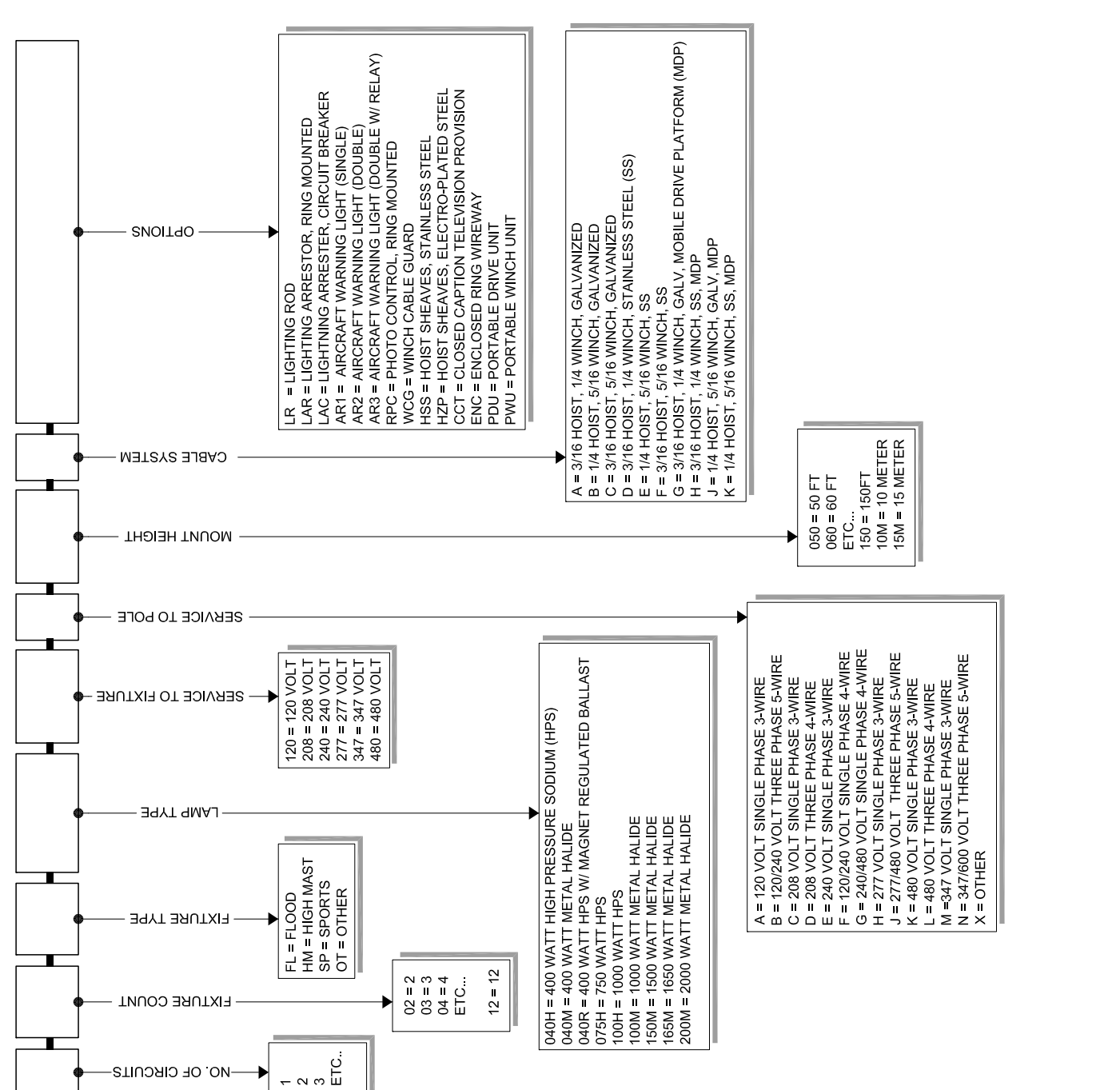
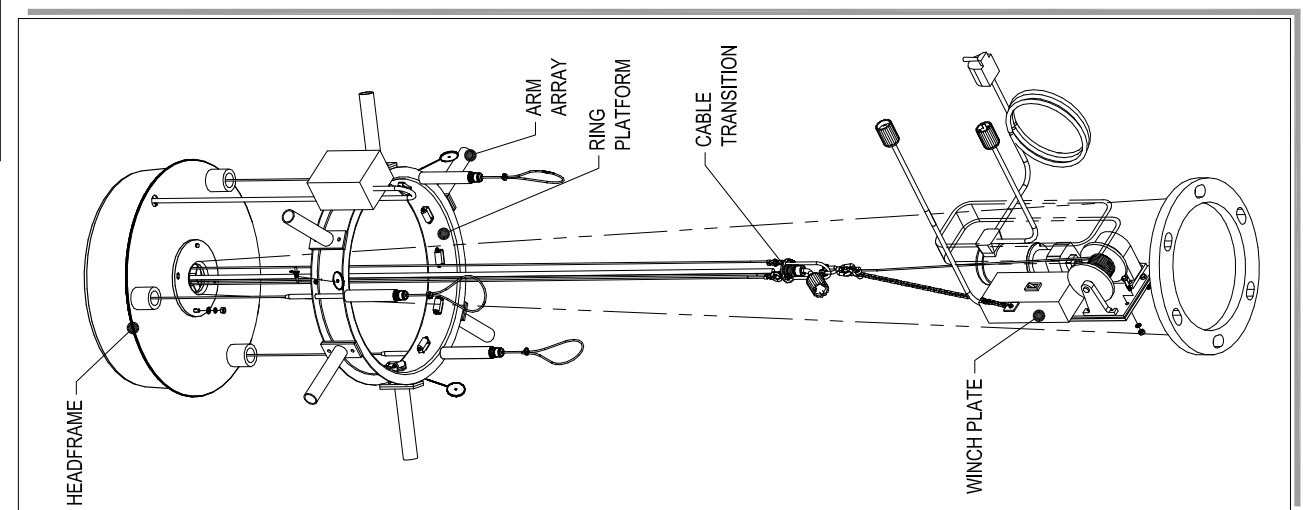

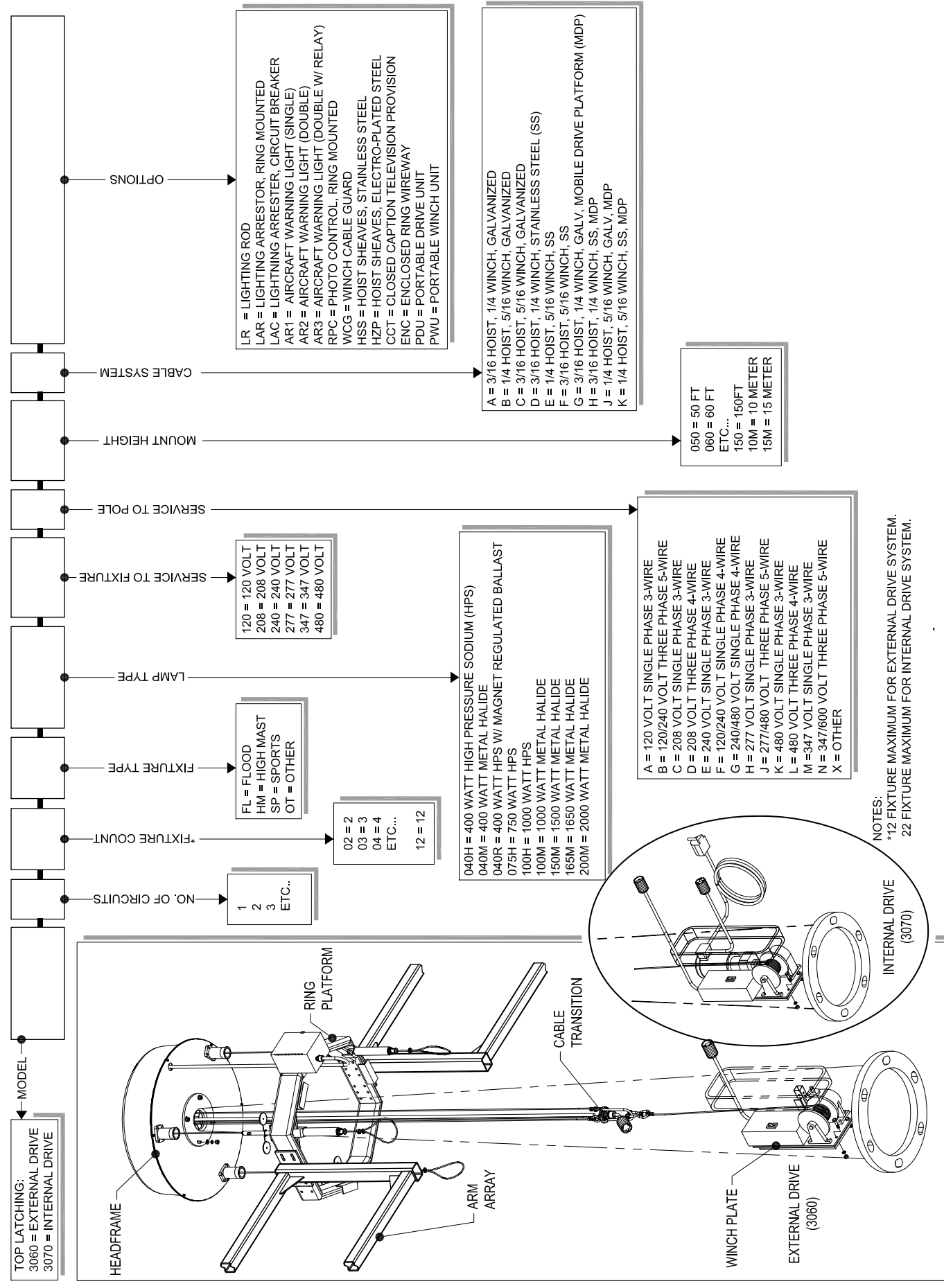

ARM ARRAY
(3060, 3070)

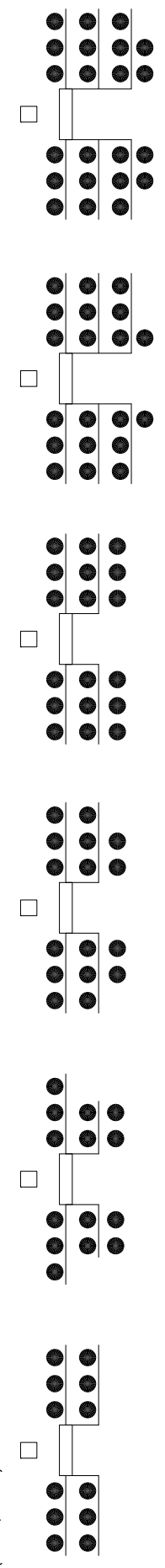

TYPICAL ARM/FIXTURE ARRAYS (OPTIONS AVAILABLE)

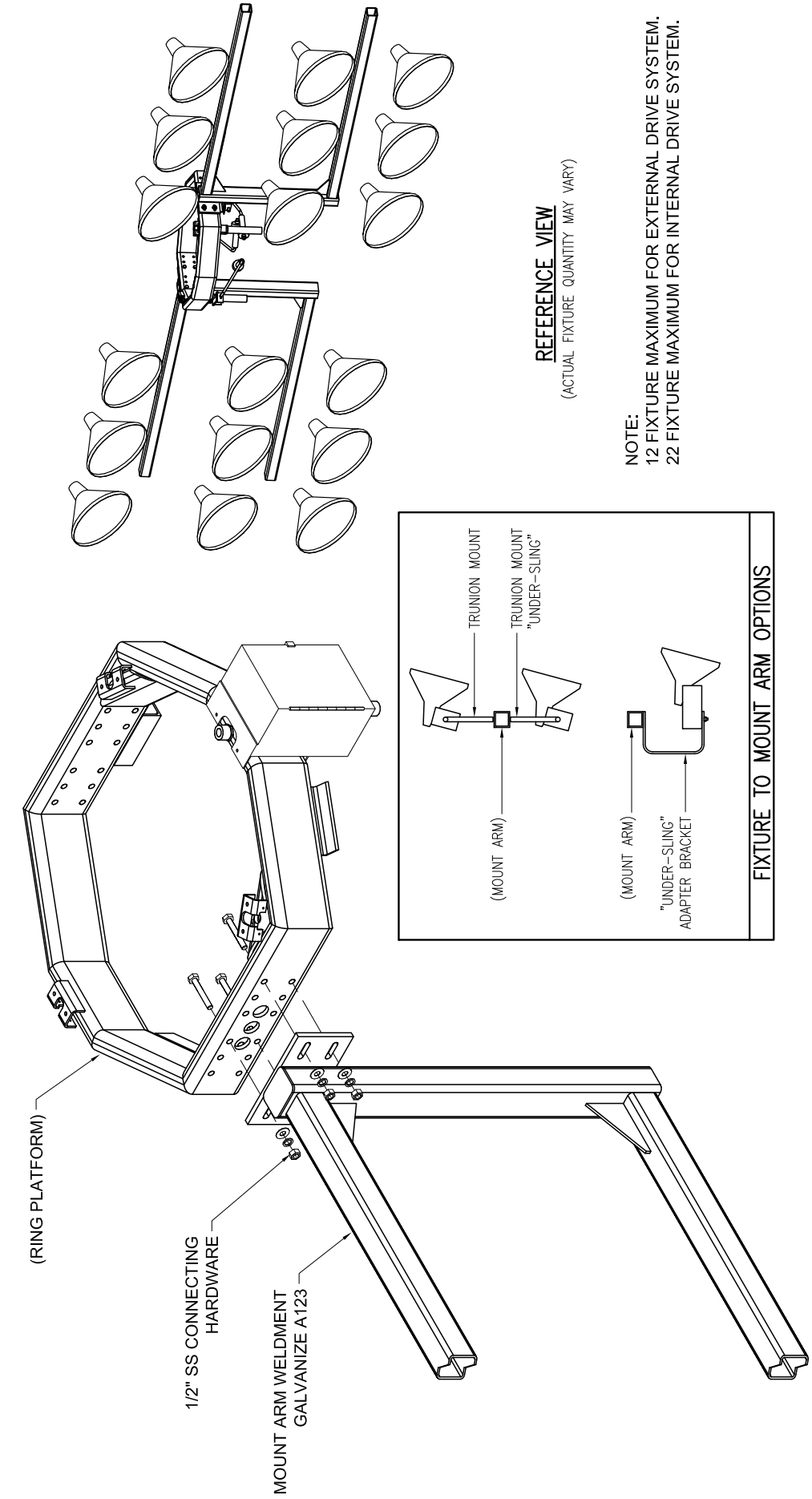

TOP LATCHING EXTERNAL WINCH / DRIVE **1080**

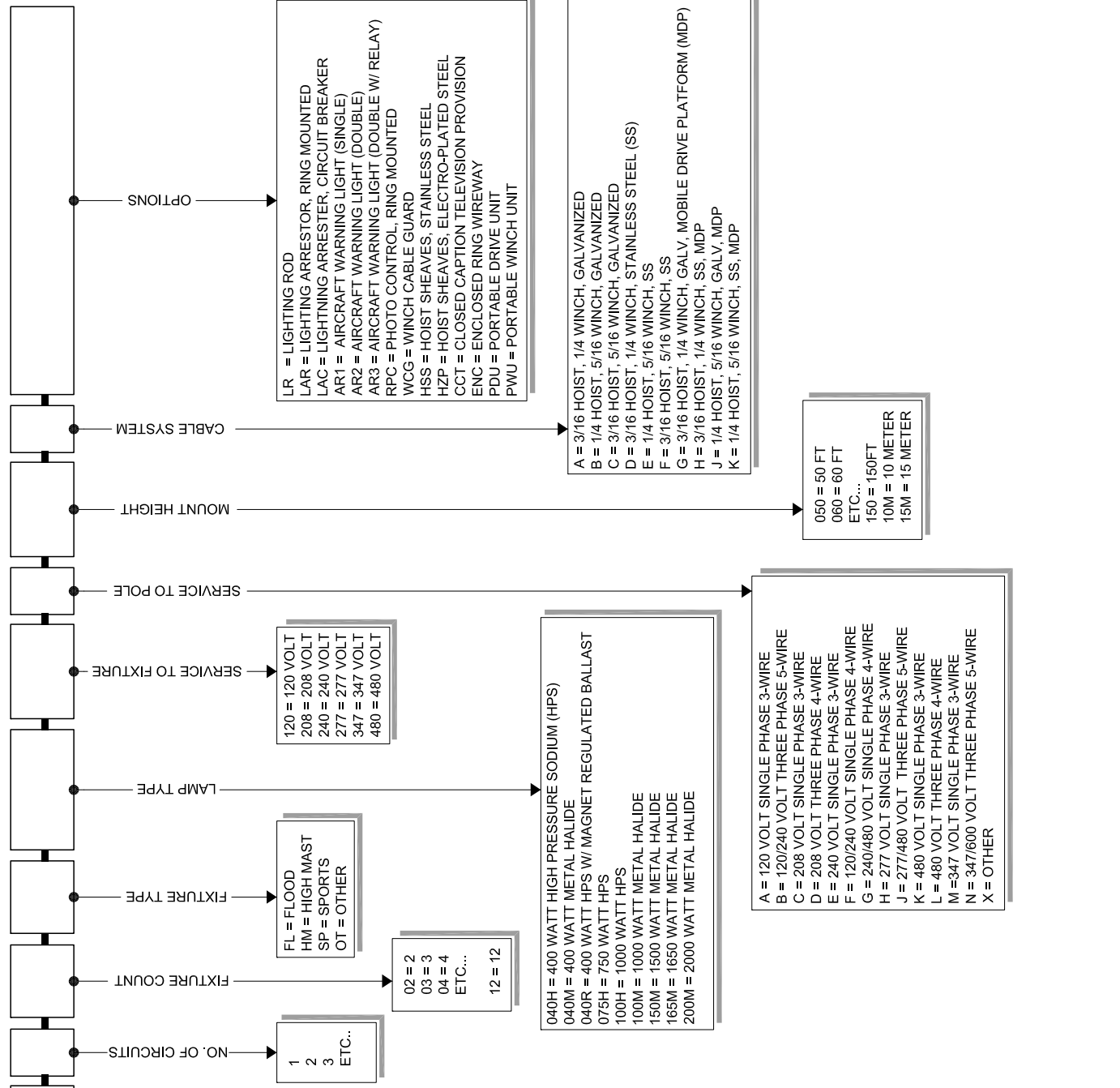
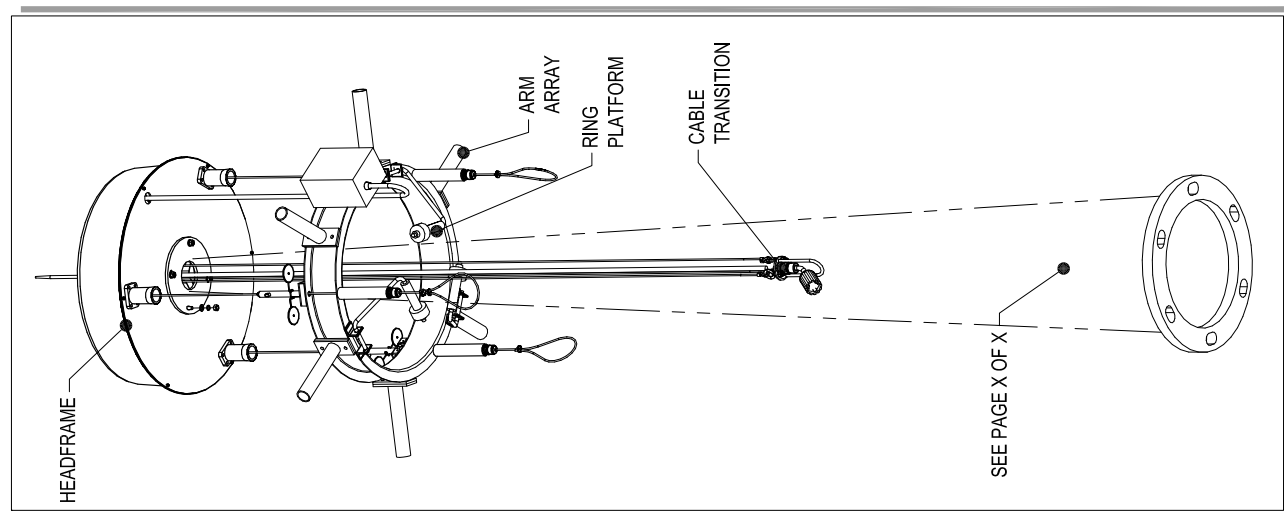

ARM ARRAY

(1060, 1070, 1080, 2060, 2070)

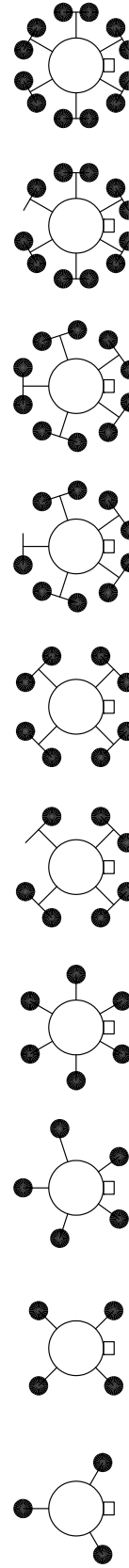

ARM ARRAY OPTIONS

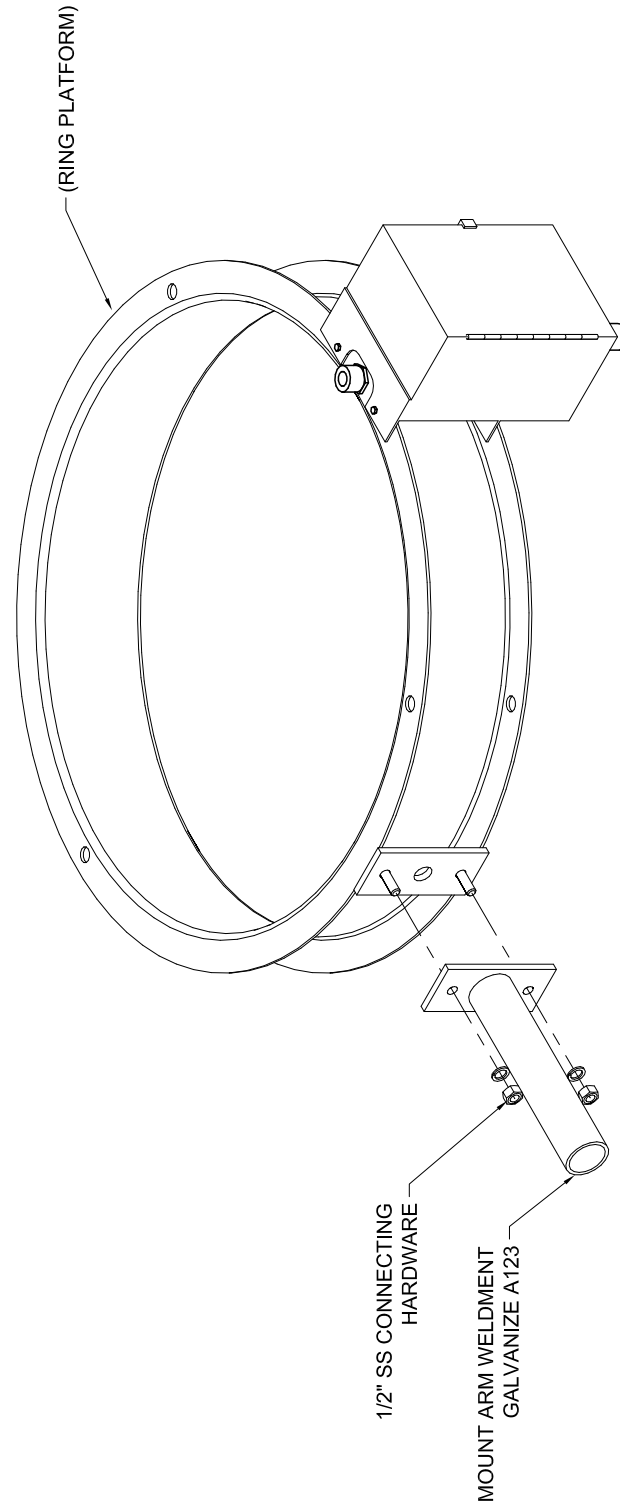

HEADFRAME (TOP LATCH)

(1060, 1070, 1080)

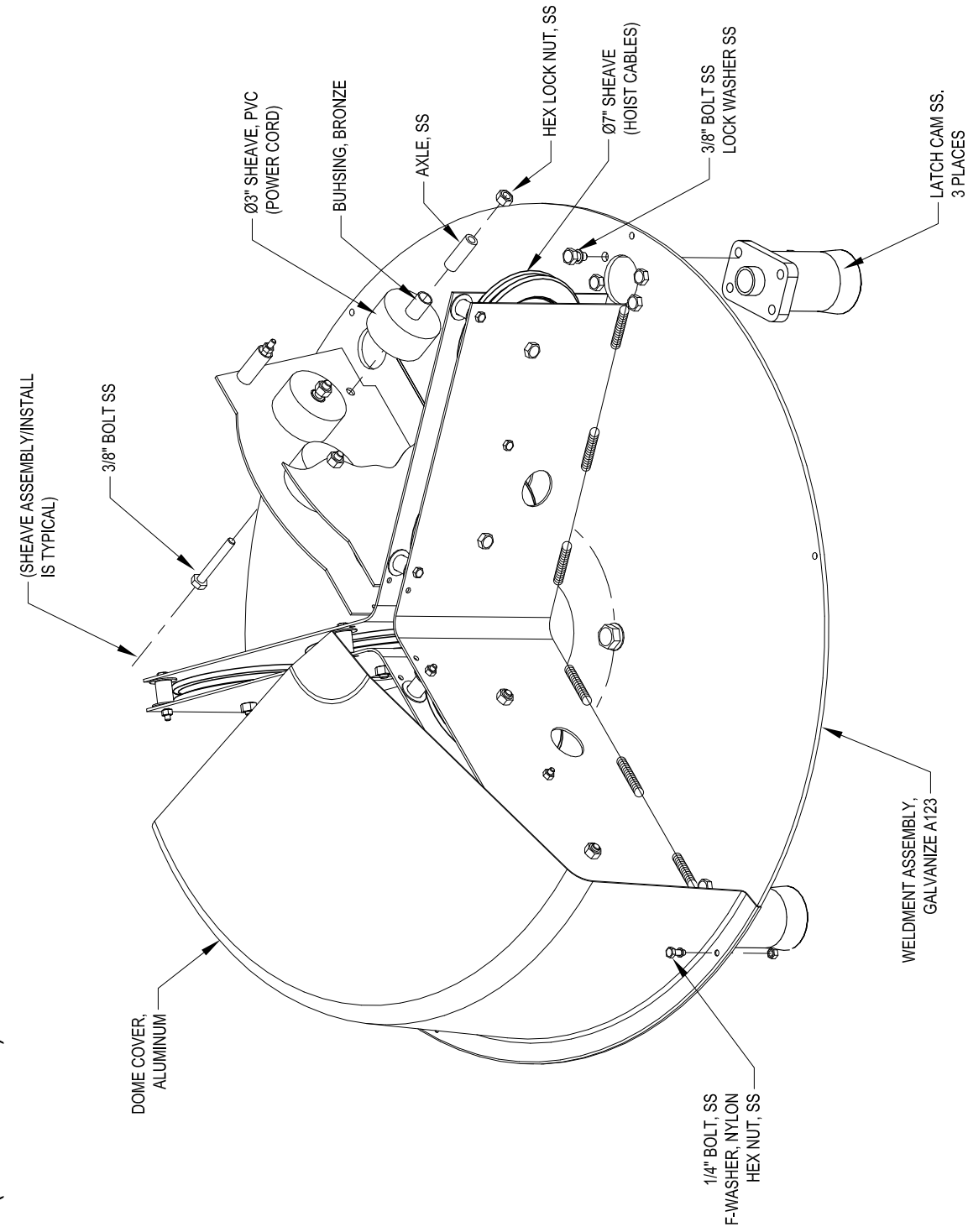

HEADFRAME (BOTTOM LATCH)

(2060, 2070)

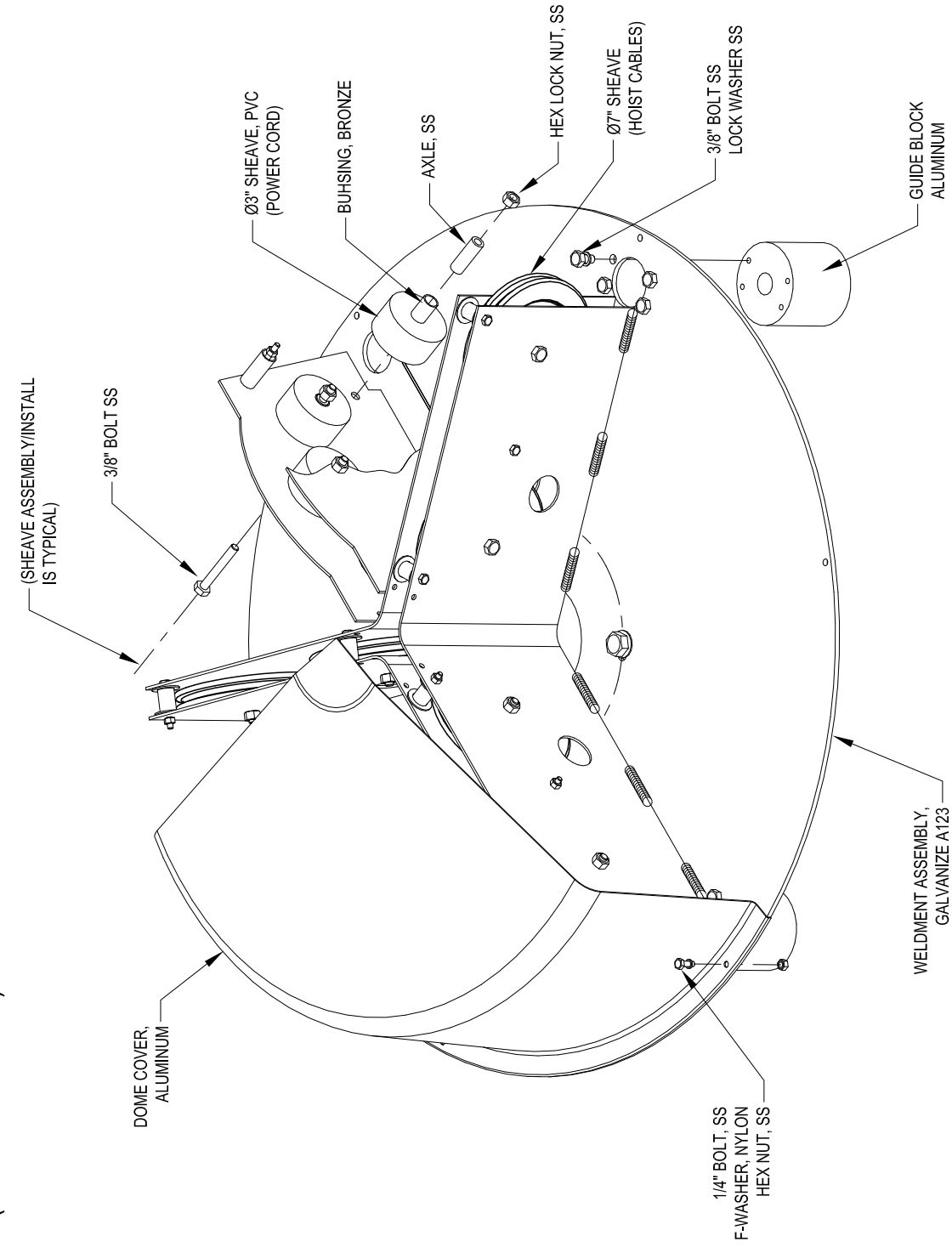

RING PLATFORM (TOP LATCH)

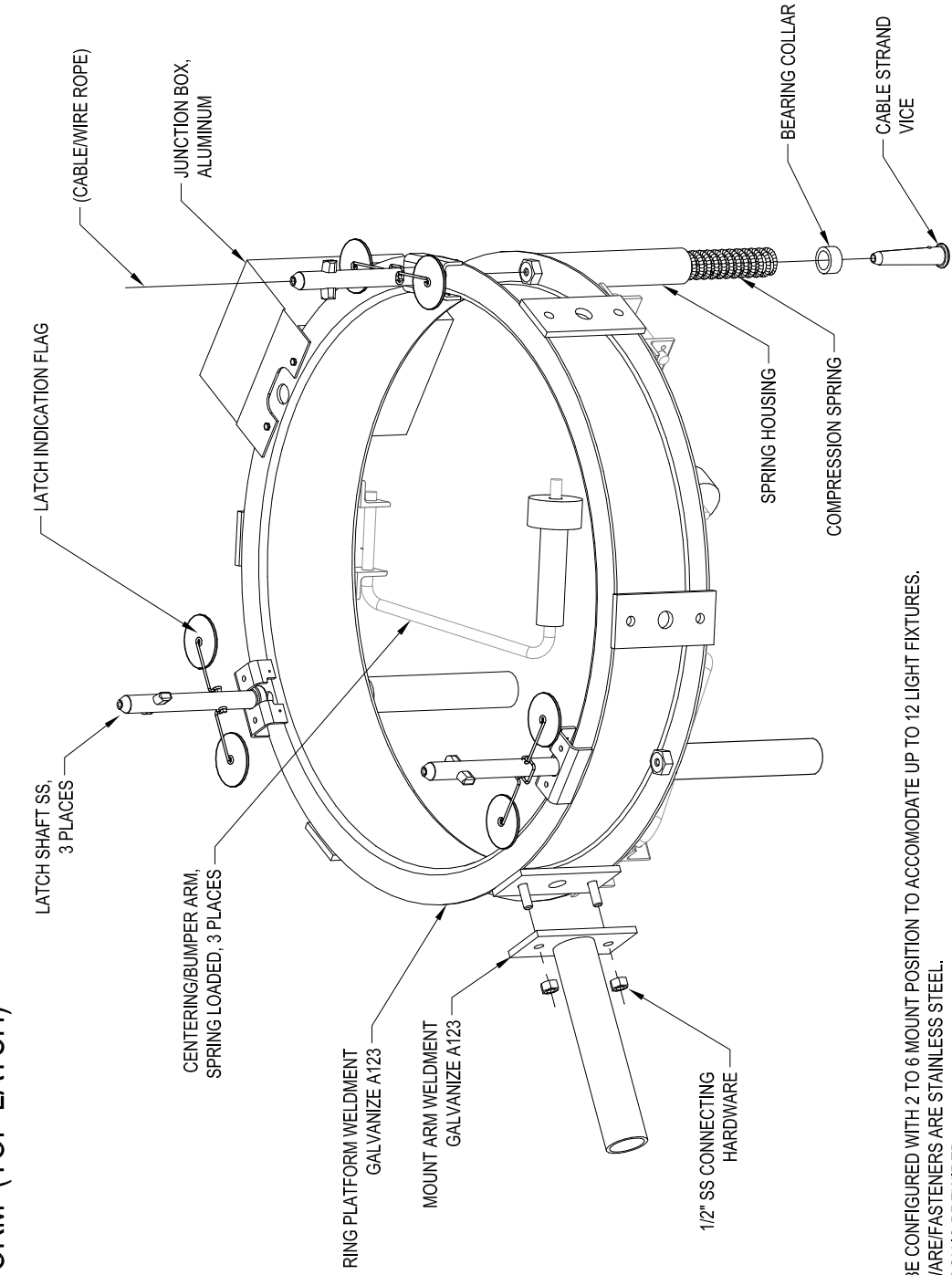

NOTES:

1. RING CAN BE CONFIGURED WITH 2 TO 6 MOUNT POSITION TO ACCOMMODATE UP TO 12 LIGHT FIXTURES.
2. ALL HARDWARE/FASTENERS ARE STAINLESS STEEL.
3. JUNCTION BOX IS PREWIRED.

RING PLATFORM (BOTTOM LATCH)

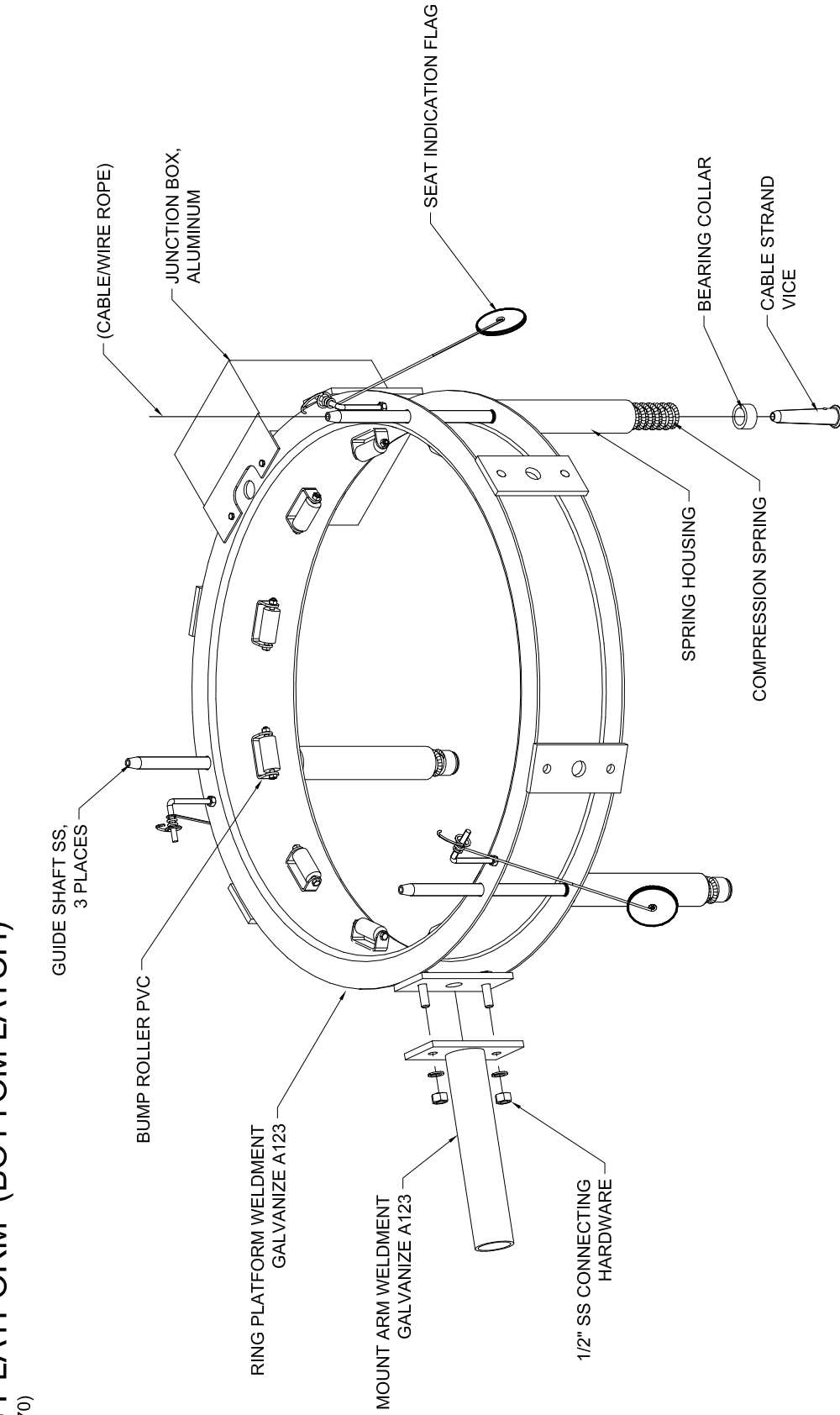

NOTES:

1. RING CAN BE CONFIGURED WITH 2 TO 6 MOUNT POSITION TO ACCOMMODATE UP TO 12 LIGHT FIXTURES.
2. ALL HARDWARE/FASTENERS ARE STAINLESS STEEL.
3. JUNCTION BOX IS PREWIRED.

RING PLATFORM (TOP LATCH)
(3070)

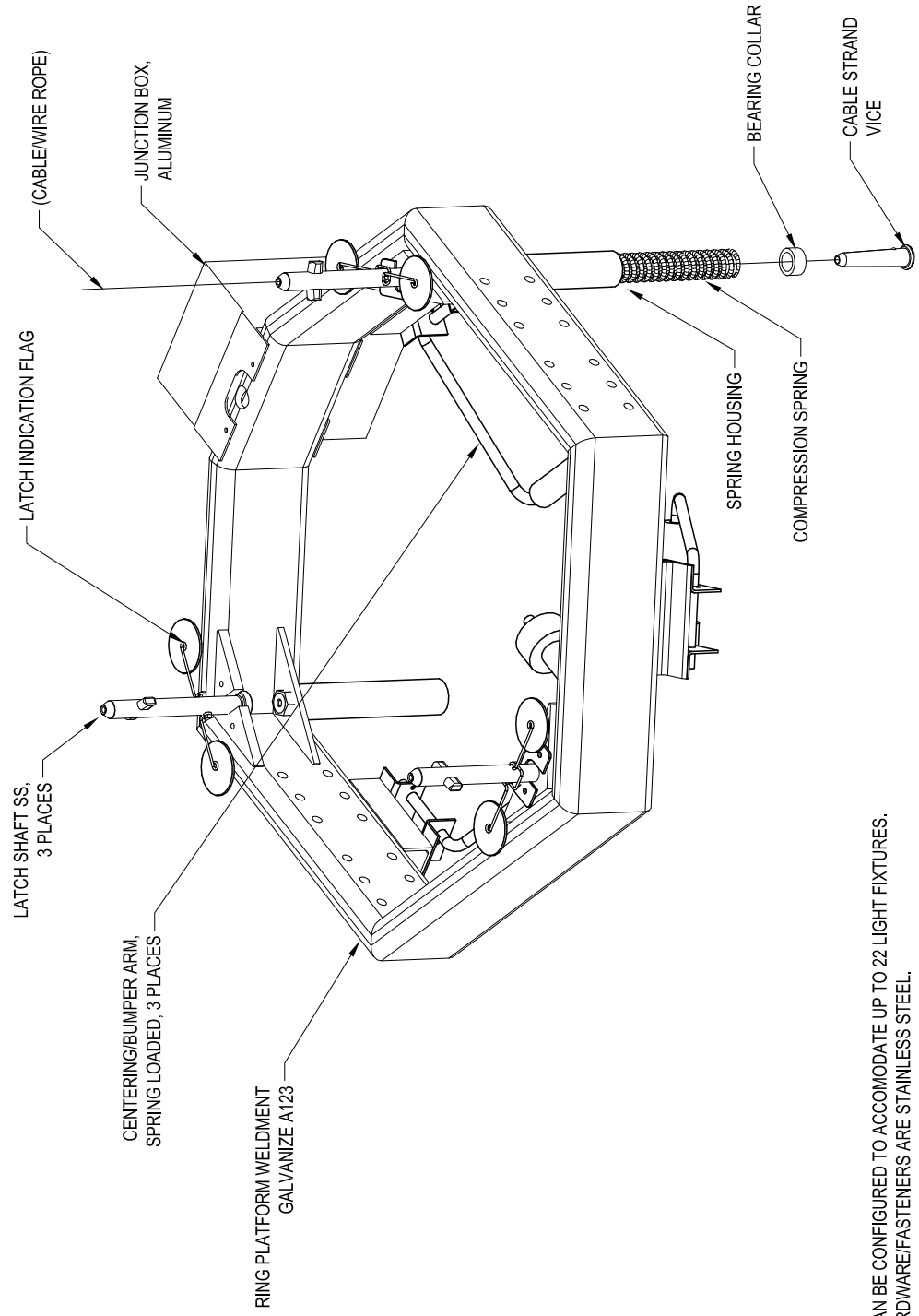

- NOTES:
1. RING CAN BE CONFIGURED TO ACCOMMODATE UP TO 22 LIGHT FIXTURES.
 2. ALL HARDWARE/FASTENERS ARE STAINLESS STEEL.
 3. JUNCTION BOX IS PREWIRED.

WINCH PLATE
(1070, 2070, 3070)

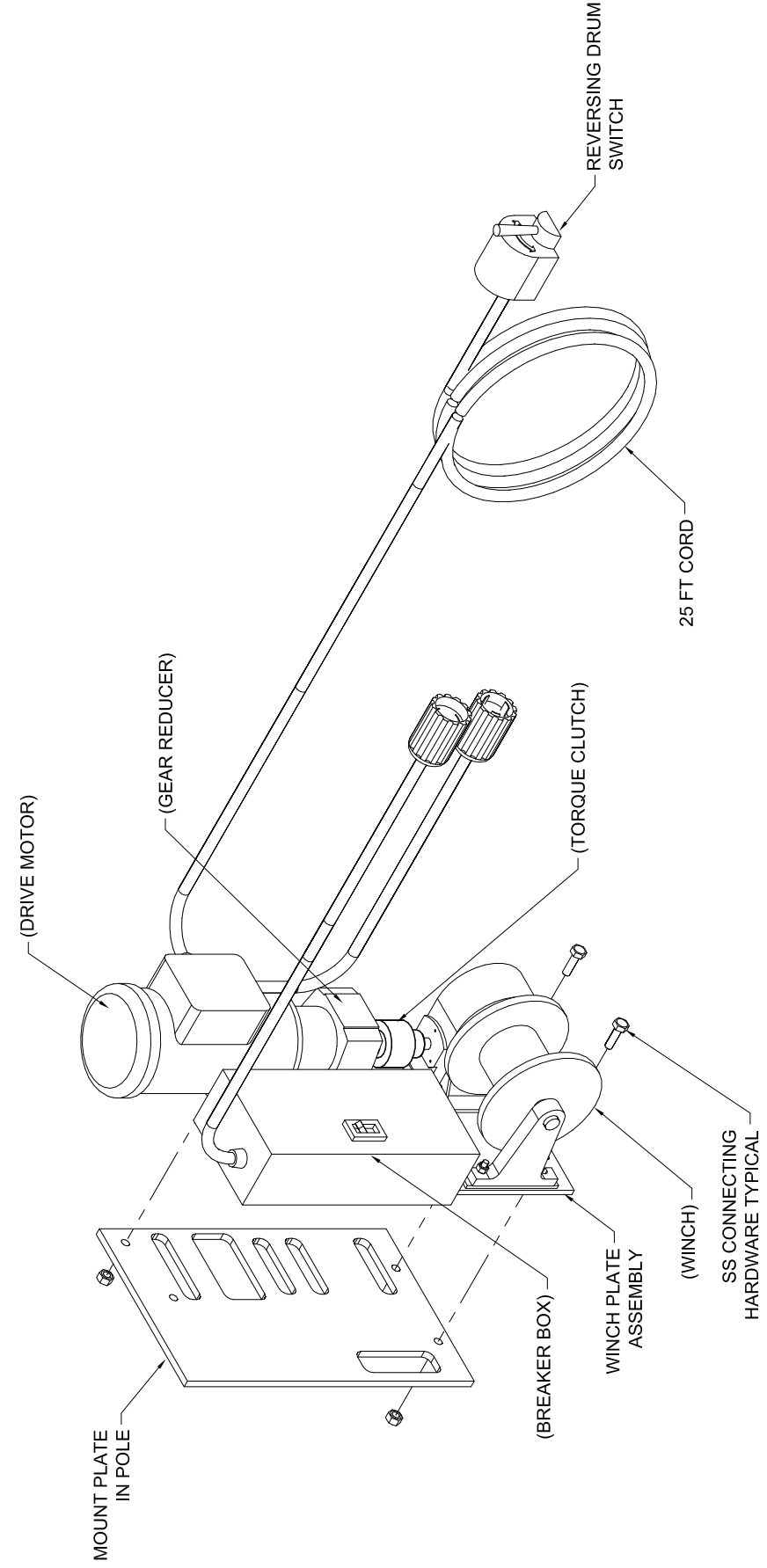

WINCH PLATE
(1060, 2060)

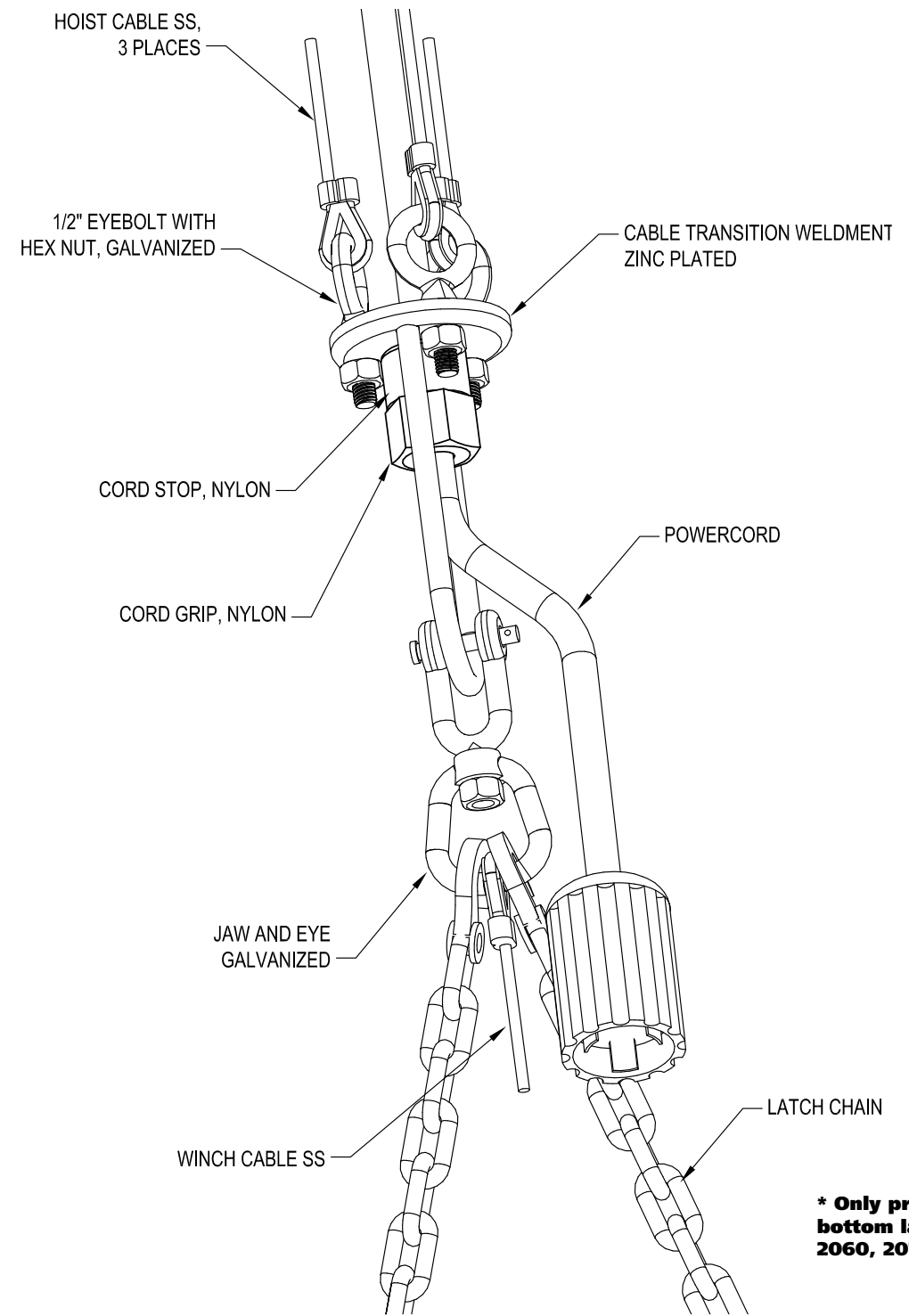
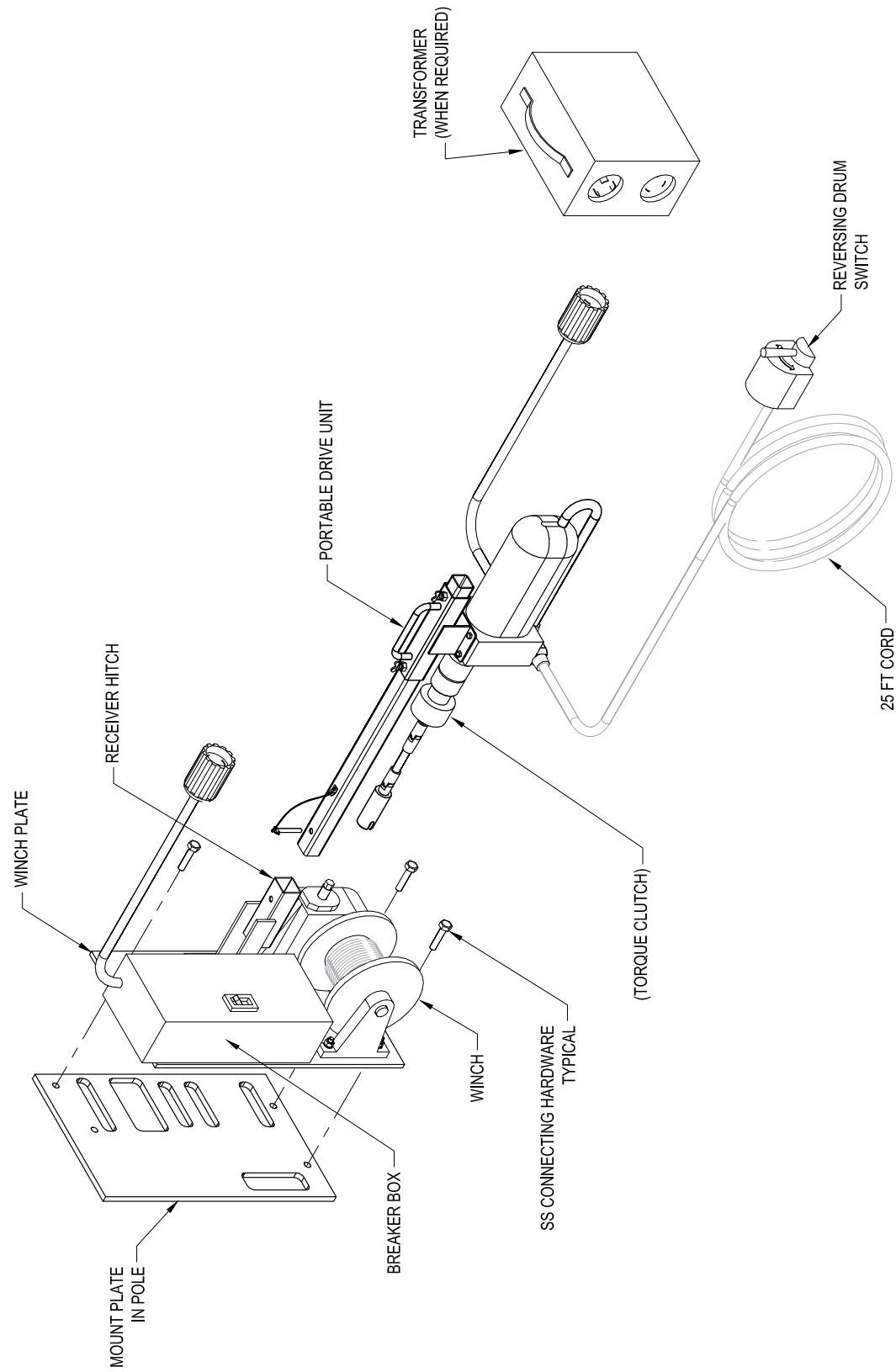

*** Only provided on bottom latch models 2060, 2070**

There are five basic models of lowering device system. This would include: 1) Top Latching and Portable Drive, 2) Top latching and Internal Drive, 3) Bottom Latching and External Drive, 4) Bottom Latching and Internal Drive, and 5) Bottom Latching with Winch/Drive. Each raising and lowering system consists of five main sub assemblies. 1) Head Frame, 2) Ring Platform, 3) Winching & Electrical, 4) Cable Transition, and 5) Drive Unit.

The system manufacturer should have a minimum of 3 years experience in the design, development, manufacture, and installation of raising and lowering devices.

The system shall be demonstrated to properly operate through 10 sequential latch-then-unlatch operations while the ring platform is out of level in relationship to the head-frame by at least 6-inches. This is done to insure that the system has the superior operability to offset issues outside the control of the manufacturer. This would include, but may not be limited to gross tolerance build, pole structure assembly or seating, weather, installation practices, maintenance practices, and inspection intervals.

It is recommended that the supporting pole structure be designed, reviewed, and sealed by a registered Professional Engineer (PE) certified in the state where the application would be installed.

Head Frame:

The main horizontal bolt plate is manufactured from 1/4" thick ASTM A36 materials. The hoist sheave gusset plates are manufactured from minimum 11-gauge (.1196"). All plates are laser cut to insure dimensional position and quality. The hoist sheave gussets are constructed from a 3 piece rigid triad supporting system. The triad support system provides a more rigid and accurately manufactured subassembly that lowering devices depend upon for structural integrity and the repeatable mechanics of operation.

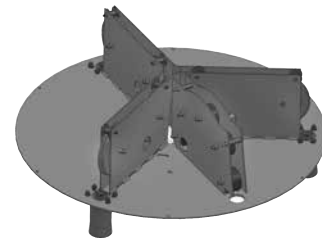

After welding the main plate and triad-gusset pieces into place, the entire unit is then hot dipped galvanized in accordance with ASTM A123 specifications. No additional cutting, drilling, or otherwise machining of the head frame is allowed after galvanizing to insure the highest quality protective coating. As a result of the triad support system the temperature of the hot dip galvanizing process does not warp the main plate or gusset plates. This in turn insures a rigid unit and alignment with the mechanical operations.

The head frame includes six aluminum hoist sheaves. Each sheave is 6.875-inch outside diameter and produces a minimum working diameter of 6-inch. The sheave and cable combination meets the requirements of the Wire Rope Technical Board. Each sheave is precision groove to properly mate the wire hoisting rope and is installed with oil impregnated, pressed-in sintered bronze bushings. The head frame also incorporates a power cord roller assembly consisting of five non conductive PVC rollers placed on a 15" arc diameter for the cord to travel. Each sheave is 3-inches in diameter and have oil impregnated, pressed-in sintered bronze bushings

7x19 stainless steel wire rope hoist cables operate over the 6.875-inch sheaves. The cables are manufactured to the United States Department of Defense Military Specification MIL-DTL-83420M and Federal Specification RR-W-410e.

Three one-piece latch cams (i.e. barrels) manufactured as an investment casting and made from ASTM A743 CF8M stainless steel are installed on the underside of the head frame assembly (top latching models). Each latch cam is designed to hold the entire weight of the ring and luminaires with a minimum safety factor of 10. The cams include an integral skirting bell shape protecting the cam surfaces from direct exposure to the elements. After heat treatment, the cams are ball bearing burnished to improve surface action and weatherability. The latch cams are precision engineered to mechanically operate and mate

with an opposing latch shaft also manufactured from a one-piece investment casting of the same material. The latch cam supports the ring platform in a latched position, unloading the transition assembly, wire rope cables, and the winch when the device is not in operation. The alternate raising and lowering of the ring will engage the turning motion of the latch shaft and thus latching and then unlatching the system to the head frame assembly. Bottom latching models are installed with guide tube cylinders in place of the latch cam. The system is then secured (latched) at the base of the pole structure by means of two chain assemblies secured to the cable transition assembly, and then again to tabs mounted on the inside of the pole structure.

The entire top section of the head frame assembly is enclosed with an aluminum dome shaped cover. The entire circumference of the cover rests equally over the surface of the head frame and is attached by means of stainless steel hardware.

Installation of the head frame will be through four 1/2" stainless steel connecting bolts. The head frame plate will be concentrically slotted to allow for rotational adjustment of the device in the field during installation.

Ring Platform:

The flanged ring is roll form from #7 gauge steel meeting the requirements of ASTM A36 specifications. The channel-web between flanges is 6-inches and each of the flanged ends measure 2-inches in length.

The rings support arm simplex plates welded to the outside flanges. The number of simplex plates will be respective to the number and orientation of the fixtures required for lighting. A mating simplex plate and luminaire tenon arm is provided for each fixture location. The tenon arms are fabricated from a minimum 2" schedule 40 pipe (2.375" OD) meeting ASTM A53 specifications. The arm lengths may vary depending upon the quantity of fixtures required and their respective orientation to one another

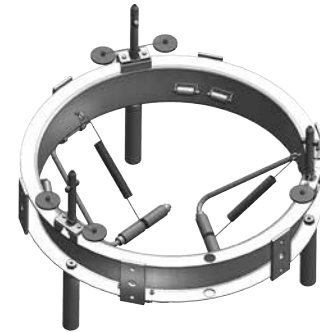

Each ring platform come prewired from the factory. The aluminum junction box provides for easy tool-less entry and is rated to NEMA 3R specifications. Inside the box the factory pre-installs din rail and combination power distribution terminal blocks as required for the lighting requirements. The distribution terminal block has separated input and output locations and is inclusive of a transparent safety screen.

The main power cable is provided in accordance with SEOOW specifications and is sized (conductor and length) in accordance with the incoming primary load, respective fixture loads and overall structure height. The fixture cables are 16/3 SEOOW. Each fixture cable is factory cut to length and wraps around the ring to the desired tenon arm, through the arm, and into the fixture head.

The factory pre-installs a male twist lock connectors and a cable stop to one end of the main power cable. The other end will be installed into the junction box in the field via a weatherproof strain relief grip that the factory will have pre-installed onto the junction box.

The back panel of the box will be provided with exit points for the luminaire cables. Gasket sheeting provides a weatherproof transition as the fixture cables exits the J-box and is strung around the ring to its desired fixture destination.

Mounted to one side of the junction box is a factory installed weatherproof test inlet. This inlet will allow fixture testing at the ground level during maintenance visits.

On the top flange the factory will install three one-piece latch shafts (top latching models) manufactured as an investment casting and made from ASTM A743 CF8M stainless. Each latch shaft is a precision engineered mating

component to the latch cam barrels located on the underside of the head frame. Attached to each latching shaft is an integrated flagging system. Each flag includes two high intensity red reflectors that alert operators when the system is latched (visible) or unlatched (hidden) from view. On bottom latching models the latch shafts are replaced with guide tubes that mate to a guide cylinder mounted on the bottom side of the head frame assembly. The flagging system appears to the operator when the ring assembly has fully engaged the guide cylinders on the head frame.

To illustrate the proper engineering and manufacturing of the lowering device, the manufacturer shall provide a demonstration of 10 sequential latch-then-unlatch operations while the ring platform is out of level in relationship to the head-frame by at least 6-inches. After each latch-then-unlatch cycle the device shall not "hang-up" or otherwise not have all three latch shafts work in sequence to each other.

On the bottom side of the ring platform three aluminum compression spring housing tubes are factory mounted. Each housing tube is a minimum of 9-inches in length to accept a 10-inch compression spring. The compression spring and housing mechanism allow the ring to self level during the latching operation and provides stability for each spring to uniformly compress without vertical distortion.

The ring assembly comes from the factory with three self centering spring arms. The arms "work" in a motion parallel to the vertical pole structure. The spring arms, springs, support brackets and hardware are all stainless steel materials. Each arm includes 6-inch long non marking rollers. The mechanism is specifically designed to keep the ring centered in relation to the pole structure and restrict the ring from bumping into the structure during operation.

Cable Transition:

The two functions of the cable transition assembly is to 1) provide a connection point between the three hoist cables and the single winch cable and 2) provide a means to center the main power cord in the structure during operation.

The transition assembly is a combination of a main plate and U-shaped rod. The U-shaped section of the assembly is a minimum of 8-inches in length. This length will allow for a smooth "sweep" and free rotation of the power cable through the transition. The entire unit is hot dip galvanized. The hoist and winch wire rope cables are factory terminated with properly sized wire rope thimbles and swaged fittings.

The hoist cables are attached to the transition assembly and are aligned via respective eye bolts. The winch cable is attached to the transition assembly via a jaw-and-eye mechanism that will allow for limited rotation of the cable during operation.



Winching & Electrical:

The winching and electrical assembly consists of a steel plate where the winch mechanism, reduction gear, breaker box, and portable drive hitch are factory installed that in turn allows direct installation to the corresponding winch plate inside the pole structure.

The winch mechanism is an enclosed oil bath 30:1 reduction worm geared system set with an internal drag brake to prevent "free-spooling". The winch

housing, drum, and outboard support arms are all manufactured from cast ductile iron. The winch has an ultimate output torque of 15,000 in/lbs, and ultimate overhung load limit of 7,500 lbs. However, the design and operation of the actual working capacity does not exceed 5:1 for either the output torque or overhung load (i.e. 3,000 in/lbs and 1,500 lbs respectively).

The winch drum comes from the factory pre-spooled with 1/4" - 7x19 stainless steel cable. The length will equal the total of the operating length for the structure plus any additional length as required to provide for one complete wrap on the spool. The pre-wrapped first layer is an additional means to properly guide the cable back to the drum during operation. The flanged end of each drum will include an anti-stacking bead that will reverse the wrapping or spooling direction of the cable.

The aluminum load center enclosure houses the systems primary circuit breaker and grounding lug. If the system is designed for multiple circuits the enclosure is inclusive of the respective number of circuit breakers. Each circuit breaker is appropriately sized for the incoming primary load and then the proper amp, volt, and phasing for the fixture load.

The factory installs a 10-foot electrical cord (a.k.a. pig tail) from the circuit breaker enclosure. From the top of the circuit breaker box it passes through a weather proof CVG connector and is terminated at the other end with a female connector.

For a portable drive model the winch plate is provided with a receiver hitch. The hitch ensures the proper alignment with the drill motor to the input shaft of the winch. For internal drive models the hitch is not required as each individual lowering device station is inclusive of its own drive motor.

Drive Unit:

For those models using a portable drive unit a support frame, electric motor, bi-directional clutch, drum switch, and possibly a step down transformer (depending upon the primary load) can be provided. The factory pre-assembles onto the support frame these components for delivery of a single unit into the field.

The motor operates at 120 volts and has a reversing capability and is provided with a 10-foot cord and male plug for connection to the step down transformer (if required). The step down transformer would convert the incoming primary load to a 120 volt capacity.

The clutch is preset at the factory and is not adjustable in the field to insure safety from tampering with the settings. The clutch is designed to activate bi-directionally. Likewise, the clutch is also capable of bi-directionally resetting itself without operator manipulation (i.e. automatic reset). Also attached to the motor is a 25-foot cord with the drum switch attached to the other end for safe distance bi-directional operation of the system.

For those models using an internal drive system the electric motor, bi-directional clutch, drum switch, and possibly a step down transformer (if required) are all factory mounted onto the winching and electrical plate.

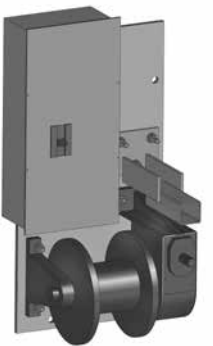



Cell Towers



Overhead Bridge Span Structures



Traffic Signal Structures



Roadway Lighting

Customer Orders: Acceptance of all customer orders by Structural & Steel Products Inc, d.b.a. Stratus Products ("Stratus") is expressly conditioned upon the Terms and Conditions of Sale contained herein. If these Terms and Conditions of Sale differ in any way from the customer (i.e. purchaser) order or if transmission of these Terms and Conditions of Sale to Purchaser constitutes or is construed as an acceptance of Purchaser's order, then additional or different Terms and Conditions set forth in Purchaser's order documents or similar communication are objected to and will not be binding upon Stratus unless specifically assented to in writing by an Officer of Stratus. In any event, the Purchaser's acceptance, including the drop shipment to a requested party, of the ordered products shall constitute and manifest Purchaser's assent to these Terms and Conditions of Sale.

Prices and Terms: All prices by Stratus are payable and due in U.S. dollars. Prices are subject to change without notice. Prices do not include any present or future sales, excise, value-added or any taxes, and where applicable such items shall be billed separately and paid by the purchaser.

Quotations: Prices quoted are subject to receipt and acceptance of order within 30 days of the quotation. Stratus has the sole and final authority with respect to the issuance of all quotations, bids, and price schedules, and the acceptance of all contracts and orders.

Terms of Payment: Unless otherwise agreed in writing by Stratus, Purchaser shall pay in full the amount of each invoice, within thirty (30) days from the date of the invoice, at Stratus' principal office or such other location as Stratus may specify. If payment is not made when due, Purchaser agrees to pay to Stratus interest on the amount past due at the rate of one and one half percent (1½%) per month (18% per annum) or the maximum lawful rate, whichever is less. Nothing herein shall be deemed to extend or otherwise modify Purchaser's obligation to make payment when due.

Credit Hold, COD, Purchases, Cost of Collection: Stratus reserves the right to place Purchaser on credit hold when any invoice has not been paid in full forty-five (45) days after the invoice date. The credit hold will apply to existing pending shipments and to all affiliates of Purchaser. Stratus may in its sole discretion require that any purchase be made on a prepaid or C.O.D. basis. In the event of Purchaser's default, Purchaser agrees to pay Stratus' reasonable attorney's fees and other reasonable costs of collection.

Freight: All quotations are freight inclusive F.O.B destination unless otherwise noted, except that anchor bolts and template pre-shipments will be shipped at the expense of, and invoiced to, the Purchaser (i.e. prepaid and add). Any reconsignment, redelivery or storage expenses shall be the responsibility of the purchaser.

Routing, Handling, and Storage: Routing will be determined by Stratus, with delivery to the common carrier delivery point nearest to destination. Handling, unloading, storage, extra labor or mechanical facilities, and movement from the shipping destination to Purchaser's job site required in connection therewith will be the responsibility of Purchaser.

Title, Risk Loss, Acceptance: In all cases, title shall pass upon delivery at the destination and thereafter all risk of loss or damage shall be upon the Purchaser. The products shall be accepted by Purchaser by an authorized and qualified representative after inspection at the delivery point. Purchaser agrees to accept delivery of the products in accordance with these Terms and Conditions within two (2) days after the delivery date. If the products are not in conformance with these Terms and conditions, Purchaser shall give written notice to Stratus of any claim to that effect setting forth in reasonable detail the manner in which the products do not conform. If Purchaser retains the products after their delivery without giving Stratus such notice as required within two (2) days after delivery, such failure shall constitute an irrevocable acceptance of the products by Purchaser except with respect to the defects not reasonably discoverable by such inspection. Purchaser's sole remedy for

any defects or nonconformance shall be in accordance with the warranty herein provided.

Product Selection: The customer shall assume all responsibilities and/or liabilities which arise or occur as a result of improper selection of products for the application, including, but not limited to, electrical service, jobsite, geological, or topographical conditions. For design or stress loading applications, such as, but not limited to, overhead wiring, guying of structures, structure mounted banner attachments, or other field installed attachments, consult Stratus for respective design analysis, and accepted acknowledgment.

Delivery: Factory shipping dates given in advance of actual shipment are estimated by Stratus and shall not be deemed to represent fixed or guaranteed shipping dates. Stratus shall not be liable for failure of or delay of performance due to (i) an act of God, act or omission of Purchaser, act of civil or military authority, government priority of other allocation or control, fire, strike, or other labor difficulty, riot or other civil disturbance, insolvency or other inability to perform by the manufacturer, delay in transportation or (ii) any other commercial impracticability. In the event of any such delay, the date of delivery or performance by Stratus shall be extended for a period equal to the time lost by reason of delay. In addition to any other right which Stratus may have hereunder or at law, Stratus may suspend shipment of any goods for which Stratus has not already received payment whenever Buyer is in default under this to any other contract of sale between Stratus and Buyer.

Job Site Visit Terms: Job site visits by Stratus personnel to assist with installation must be prearranged with Stratus a minimum of two (2) weeks in advance with Stratus, if the job site is within the continental United States, or a minimum of thirty (30) days in advance, if the job site is outside the continental United States. The purchaser will receive a written confirmation of the scheduled visit once travel arrangements have been secured and purchased by Stratus. If the Purchaser changes the job visitation itinerary after confirmation, any additional expenses incurred by Stratus due to the change will be the responsibility of, and invoiced to, the Purchaser. Job site visits pursuant to this paragraph shall not create or increase any rights of Purchaser beyond those expressly set forth in paragraph 10 below.

Warranty, Limitation of Liability: Stratus warrants that the Stratus Products ("Products") will, upon shipment be free from defects in materials and workmanship. Products will be manufactured according to Purchaser's approved Submittals if Purchaser has given, in its entirety, an original approved stamp copy of the Submittal which has been approved by the Owner, or owner's Representative. Stratus agrees to correct, and retains the right, in its sole discretion, to correct by repair or replacement, at its sole expense, and at its option, either at Stratus' factory or at the installation site, defects in materials or workmanship which may appear as a result of normal and proper use within one year (1) from the date of shipment (the "Warranty Period"), if inspection proves that such defects existed at the time of shipment, if Purchaser gives to Stratus immediate written notice of such defects within the Warranty Period, and if during the warranty Period the Products have been properly cared for and operated under normal condition by component personnel under competent supervision. Any transportation cost in connection with correction of defects in Stratus Products shall be payable by the Purchaser. Stratus does not warranty any Products that are altered, except in its sole discretion by written notice to Purchaser from Stratus' Customer Service Department prior to alteration; otherwise, this Warranty is null and void as to the altered Products. Repair or replacement of any products shall be Stratus' only obligation and the sole and exclusive remedy of the Purchaser in the event of a failure to conform to this warranty. Stratus shall not be responsible for any damage resulting from improper storage or handling by employees, agents or contractors of Purchaser. Stratus shall not assume any expense or liability for repairs made to any purchased equipment and accessories not warranted by Stratus, but Stratus hereby passes the original manufacturer's warranties to the Purchaser to the fullest extent

possible. This warranty covers Stratus' own products only and does not extend to the failures in performance due either to defects in any equipment or component not manufactured by Stratus or to improper or insufficient information furnished to Stratus regarding the performance of the equipment in question. This warranty is exclusive and in lieu of all other warranties (except that of title) express of implied, including, but not limited to the implied warranties of merchantability and fitness for a particular purpose. The maximum liability of Stratus with the respect to any products (whether in tort, in strict liability, in contract or otherwise) will not exceed the purchase price paid by the purchaser. In no event will Stratus be liable in tort, in strict liability, in contract, or otherwise for any special indirect, incidental, or consequential, or consequential damages, including (but not limited to) loss of anticipated profits of revenues, loss of use, non-operation or increased operation cost, costs of capital, or claims or customers or purchasers.

Claim for Shortages: All claims for shortages must be in writing two (2) days from the receipt of shipment at destination.

Returned Goods: Specific written request must be made in advance by Purchaser to obtain credit or replacement on goods returned. The authorization to return goods will be at the sole discretion of Stratus and only upon written notice to Purchaser from an officer of Stratus. On goods accepted for return, Purchaser must prepay 100% the return shipment expense and pay a minimum restocking charge of thirty-five percent (35%) plus any charges necessary to rework goods to a re-sellable condition. Stratus reserves the right to reject, in entirety, any return requests.

Cancellation: Written consent of Stratus must be obtained prior to a cancellation of any order. Cancellation of any order will subject the Purchaser to a cancellation charge based upon any and all material, engineering, or administrative expenses already incurred and any commitments made by Stratus pursuant to the execution of the customer order.

Assignment: The delegation or assignment by Purchaser of any or all duties or rights hereunder without the prior written consent made by Stratus Officer shall be void.

General: Stratus reserves the right to change any feature of its published specifications without notice to promote production improvement and/or allow for materials availability. Any representation, affirmation of fact and course of dealings, promise or condition in connection therewith or usage of trade not incorporated herein, shall not be binding on either party. No waiver, alteration to modification of any of the provisions hereof shall be binding upon Stratus unless specifically assented to in writing by an Officer of Stratus. The contract of the sale of goods between Stratus and purchaser shall be performed in Tarrant County, Texas. The validity, performance, and all matters relating to the interpretation and effect hereof and any amendment hereto shall be governed by the laws of the State of Texas. Any controversy or claim arising out of or relating to this contract, or the breach thereof, shall be settled by arbitration administered by the American Arbitration Association under its Construction Industry Arbitration Rules, taking place in Tarrant County, Texas. Judgment of the award rendered by the arbitrator (s) may be entered in any court having jurisdiction thereof. The parties also expressly agree that they will cooperate in the exchange of documents and lists of witnesses (including any experts) before the arbitration as well as interviewing or deposition of witnesses. The prevailing party in any arbitration shall be entitled to recovery of its reasonable expenses incurred in enforcing these Terms and Conditions.

Authority: The person signing on behalf of Purchaser represents and warrants to Stratus that such person is an authorized agent of Purchaser, with full power and authority to enter into the agreement defined by these Terms and Conditions.

Effective Date: These terms and Conditions supersede any previous issues.

STRATUS PRODUCT CATALOGS

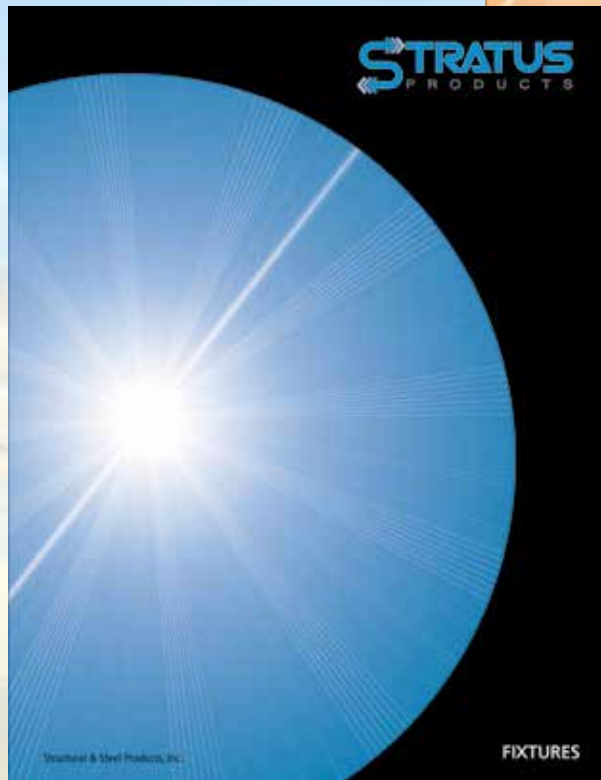
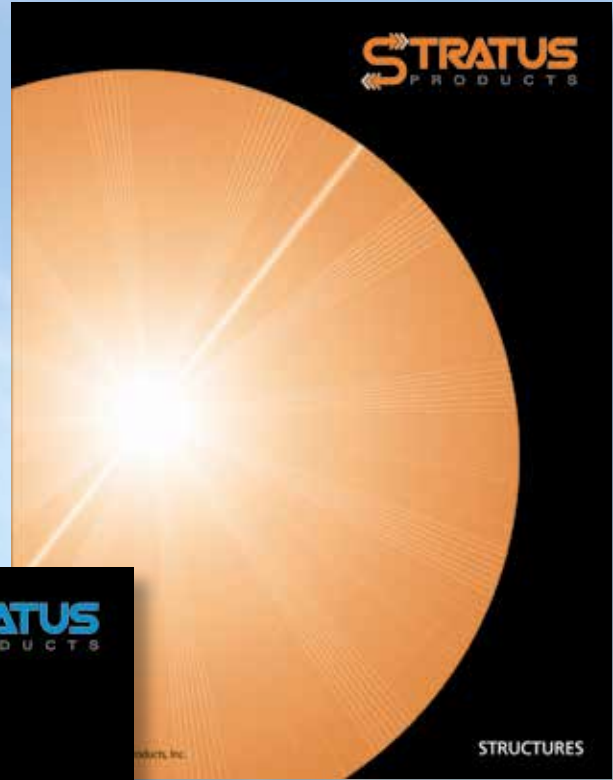
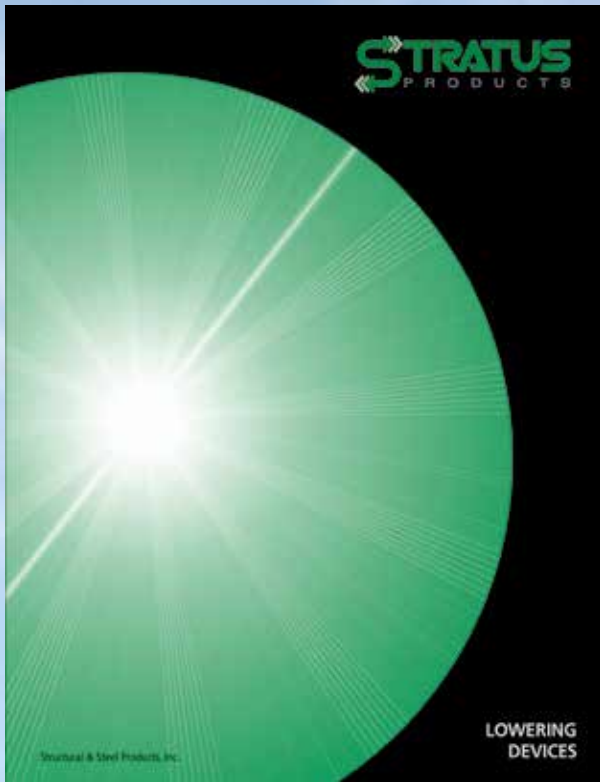

*CONTACT STRATUS FOR
YOUR CATALOG*

1320 South University
Suite 701
Fort Worth, Texas 76107

1.800.782.5804 Toll free

www.s-steel.com





1320 South University
Suite 701
Fort Worth, Texas 76107

1.800.782.5804 Toll free

www.s-steel.com

Structural & Steel Products, Inc.