



QuadGuard[®] Elite M10 Wide [69"]

CRASH CUSHIONS

PRODUCT MANUAL



PN 626821

AUGUST 2022

QuadGuard® Elite M10 Wide [69"]

The QuadGuard® Elite M10 Wide has been tested pursuant to American Association of State Highway and Transportation Officials (“AASHTO”) Manual for Assessing Safety Hardware (“MASH”) specifications. The QuadGuard® Elite M10 Wide has been deemed eligible for federal-aid reimbursement on the National Highway System by the Federal Highway Administration (“FHWA”).

Product Description Assembly Manual



15601 Dallas Parkway
Suite 525
Addison, Texas 75001



Warning: The local highway authority, distributors, owners, contractors, lessors, and lessees are **RESPONSIBLE** for the assembly, maintenance, and repair of the QuadGuard® Elite M10 Wide. Failure to fulfill these **RESPONSIBILITIES** with respect to the assembly, maintenance, and repair of the QuadGuard® Elite M10 Wide could result in serious injury or death.



Important: These instructions are for standard assembly specified by the appropriate highway authority. In the event the specified system assembly, maintenance, or repair would require a deviation from standard assembly parameters, contact a Valtir representative. This system has been deemed eligible by the FHWA for use on the national highway system under strict criteria utilized by that agency.

This manual must be available to the worker overseeing and/or assembling the product at all times. For additional copies, contact Valtir directly at (888) 323-6374 or visit Valtir.com.

The instructions contained in this manual supersede all previous versions. The instructions, illustrations, and specifications are based on the latest QuadGuard® Elite M10 Wide information available to Valtir at publication. We reserve the right to make changes at any time. Please visit Valtir.com/Product/QuadGuard-Elite-M10/ to confirm the latest revision.

Table of Contents

Customer Service Contacts	3
Important Introductory Notes	3
Safety Symbols	4
Safety Rules for Assembly	4
Limitations and Warnings	5
System Overview	6
Inspect Shipping	6
System Components	7
Select Transition	11
Recommend Tools	12
Site Preparation/Foundation	14
Foundation/Anchoring	15
Valtir Approved Adhesive Anchoring System	16
Vertical Anchors	16
Steel Rebar Anchor Assembly Cautions	17
Horizontal Anchors	18
System Assembly	21
QuadGuard® Elite M10 Wide Final Inspection Checklist	37
Maintenance and Repair	38
Visual Drive-By Inspection	38
Walk-Up Inspection	38
Maintenance Flow Chart	40
Post-Impact Instructions	41
Parts Ordering Procedure and Drawings	44
QuadGuard® Elite M10 Wide QGEMTSCVR8-U69	46
Backup Assembly, Tension Strut 627528	47
Bay 1 Diaphragm Assembly 627506	48
Standard Diaphragm Assembly 627506	49
Fender Panel Assembly 608240	50
Cylinder Attachment 618879	51
Nose Assembly 627505	52
Hit Indicator 610237	53
Monorail Assembly 625637	54
TS Concrete Pad 618686	55
TS Concrete Pad 8" w/Rebar 618686	56
TS Concrete Pad 8" wo/Rebar 618686	57
31" W-Beam Transition QFEMTSCVR-TWLR	58
Thrie-Beam Transition QFEMTSCVR-TTLR	59
4" Safety Shape Transition QFEMTSCVR-T4LR	60
4" Safety Shape Flared Transition QFEMTSCVR-T4LRF	61
6" Single Slope Transition QFEMTSCVR-T6LR	62
6" Single Slope Flared Transition QFEMTSCVR-T6LRF	63
End Shoe Transition QFEMTSCVR-ESLR	64

Customer Service Contacts

Valtir is committed to the highest level of customer service. Feedback regarding the QuadGuard® Elite M10 Wide system, its assembly procedures, supporting documentation, and performance is always welcome. Additional information can be obtained from the contact information below:

Valtir:

Telephone:	(888) 323-6374 (USA) +1 312 467 6750 (International)
Contact Link	Contact">Valtir.com>Contact

Important Introductory Notes

Proper assembly of the QuadGuard® Elite M10 Wide system is critical to achieve performance that has been evaluated and deemed eligible by the FHWA per AASHTO MASH criteria. These instructions should be read in their entirety and understood before assembling the QuadGuard® Elite M10 Wide. These instructions are to be used in conjunction with the assembly of QuadGuard® Elite M10 Wide and are for standard assemblies only as specified by the applicable highway authority. If you need additional information, or have questions about the QuadGuard® Elite M10 Wide, please contact the highway authority that has planned and specified this assembly and, if needed, contact Valtir Customer Service. This product must be assembled in the location specified by the appropriate highway authority. If there are deviations, alterations, or departures from the assembly protocol specified in this manual, the device may not perform as tested.



Important: DO NOT use any component part that has not been specifically approved for this system during the assembly or repair of this system.

This product has been specified for use by the appropriate highway authority and has been provided to that user who has unique knowledge of how this system is to be assembled. No person should be permitted to assist in the assembly, maintenance, or repair of this system that does not possess the unique knowledge described above. These instructions are intended for an individual qualified to both read and accurately interpret them as written. These instructions are intended only for an individual experienced and skilled in the assembly of highway products that are specified and selected by the highway authority.

A manufacturer's drawing package will be supplied by Valtir upon request. Each system will be supplied with a specific drawing package unique to that system. Such drawings take precedence over information in this manual and shall be studied thoroughly by a qualified individual who is skilled in interpreting them before the start of any product assembly.

Safety Symbols

This section describes the safety symbols that appear in this QuadGuard® Elite M10 Wide manual. Read the manual for complete safety and assembly information.

Symbol

Meaning



Safety Alert Symbol: Indicates Important, Caution, Warning, or Danger. Failure to read and follow the Important, Caution, Warning, or Danger indicators could result in serious injury or death to workers and/or bystanders.



Warning: Read safety instructions thoroughly and follow the assembly directions and suggested safe practices before assembling, maintaining, or repairing the QuadGuard® Elite M10 Wide. It is the responsibility of the installer to follow the instructions contained in this manual. Failure to comply with these warnings could result in increased risk of serious injury or death in the event of a vehicle impact.



Important: Please keep up-to-date instructions for later use and reference by anyone involved in the assembly of the product.

Safety Rules for Assembly

*** Important Safety Instructions ***

This manual must be kept in a location where it is readily available to persons who are skilled and experienced in the assembly, maintenance, or repair of the QuadGuard® Elite M10 Wide. Additional copies of this manual are available from Valtir by calling (888) 323-6374 or by visiting Valtir.com/Product/QuadGuard-Elite-M10/. Please contact Valtir if you have any questions concerning the information in this manual or about the QuadGuard® Elite M10 Wide.



Warning: It is the responsibility of the installer to use appropriate safety precautions when operating power equipment, mixing chemicals, and when moving heavy equipment or QuadGuard® M10 Wide components. Safety articles including but not necessarily limited to work gloves, eye protection, safety-toe shoes, and back protection should be used.



Warning: It is the responsibility of the installer to use all safety measures incorporating appropriate traffic control devices specified by the highway authority. These measures must be used to protect all personnel while at the assembly, maintenance, or repair site.



Warning: Use only Valtir parts on the QuadGuard® Elite M10 Wide for assembly, maintenance, or repair. The use of component parts not specified herein is **strictly prohibited**. The QuadGuard® Elite M10 Wide assembled with Valtir parts has been tested, approved, and accepted for state use by the FHWA. A QuadGuard® Elite M10 Wide Assembly using parts other than those specified herein has not been tested, approved, or accepted for state use by the FHWA. Failure to follow this warning could result in increased risk of serious injury or death in the event of a vehicle impact.

Limitations and Warnings

Pursuant to **MASH** “Recommended Procedures for the Safety Performance of Highway Safety Features”, Valtir contracts with FHWA approved testing facilities to perform and evaluate crash tests to prepare a crash test results report. Valtir is then able to submit a Request for Federal Aid Reimbursement of Safety Hardware Devices to the FHWA for review.

The QuadGuard® M10 Wide has been deemed eligible by FHWA as meeting the requirements and guidelines of MASH. These tests evaluate product performance defined by AASHTO involving lightweight cars (approx. 2420 lb. [1100 kg]) and full size pickup trucks (approx. 5000 lb. [2270 kg]). A product can be certified for multiple Test Levels. The QuadGuard® M10 Wide is certified to the Test Level(s) as shown below:

Test Level 3: 62 mph [100 kph]

These AASHTO directed tests are not intended to represent the performance of systems when impacted by every vehicle type or every impact condition existing on the roadway. This system is tested only to the test matrix criteria of MASH as approved by FHWA.

Valtir expressly disclaims any warranty or liability for injury or damage to persons or property resulting from any impact, collision or harmful contact with products, other vehicles, or nearby hazards or objects by any vehicle, object or person, whether or not the products were assembled in consultation with Valtir or by third parties.

The QuadGuard® Elite M10 Wide is intended to be assembled, delineated, and maintained within specific state and federal guidelines. It is important for the highway authority specifying the use of a highway product to select the most appropriate product configuration for site specifications. The customer should be careful to properly select, assemble, and maintain the product. Careful evaluation of site layout, traffic speed/type, direction, and visibility are some of the elements that require evaluation by the highway authority in the selection of a highway product. For example, curbs could cause an untested effect on an impacting vehicle.

After an impact occurs, the debris from the impact should be removed from the area immediately and the specified highway product should be evaluated and restored to its original specified condition or replaced as the highway authority determines as soon as possible.



Warning: Do not assemble, maintain, or repair the QuadGuard® Elite M10 Wide until you have read this manual thoroughly and completely understand it. Please contact Valtir if you do not understand these instructions (p. 3).



Warning: It is the responsibility of the installer to ensure that all Danger, Warning, Caution, and Important statements within the QuadGuard® Elite M10 Wide manual are completely followed. Failure to follow this warning could result in serious injury or death in the event of a collision.

System Overview

The QuadGuard® Elite M10 Wide is a potentially reusable, re-directive, non-gating crash cushion for roadside features of 69" [1,753 mm]. It consists of energy-absorbing high density polyethylene cylinders surrounded by a framework of Quad-Beam Panels.



Important: Valtir makes no recommendation whether use or reuse of any part of the system is appropriate or acceptable following an impact. It is the sole responsibility of the project engineer and/or the local highway authority and its engineers to make that determination. It is critical that you inspect this product after assembly is complete to make certain that the instructions provided in this manual have been strictly followed.

The QuadGuard® Elite M10 Wide utilizes three types of Cylinders in a “staged” configuration that are designed and tested to address vehicles as defined by MASH for both lighter cars and heavier, high center-of-gravity vehicles.

Impact Performance

The **8 Bay** QuadGuard® Elite M10 Wide has successfully passed MASH requirements stipulated for Test Level 3 tests with both the light car and pickup trucks at speeds of up to **62 mph [100 kph]** at angles up to 25 degrees.

During head-on impact testing, within MASH criteria, the QuadGuard® Elite M10 Wide has been shown to telescope rearward to absorb the energy of impact. When impacted from the side, within the applicable MASH criteria, it has been shown to redirect the vehicle back toward its original travel path and away from the highway feature.



Warning: It is the sole responsibility of the project engineer and/or local highway authority and its engineer to ensure that the delineation used for the QuadGuard® Elite M10 Wide meet all federal, state, specifying agency, and local specifications.



Warning: It is the sole responsibility of the project engineer and/or local highway authority and its engineer to ensure that the QuadGuard® Elite M10 Wide meets all appropriate Manual on Uniform Traffic Control Devices (“MUTCD”) and local standards.

Inspect Shipping

Check the received parts against the shipping list supplied with the system before deploying the QuadGuard® Elite M10 Wide. Make sure all parts have been received (pp. 7 - 11).



Important: The manufacturer’s drawing package supplied with the QuadGuard® Elite M10 Wide must be used with these instructions for proper assembly and should take precedence over these general instructions.









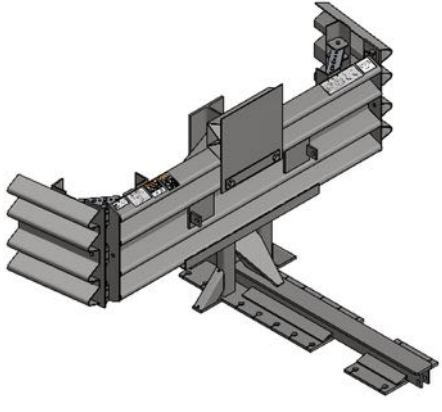
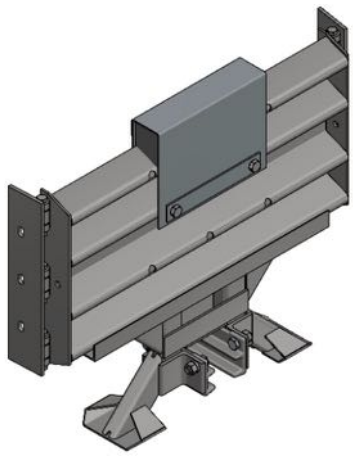

Warning: Do NOT modify the QuadGuard® Elite M10 Wide in any way.

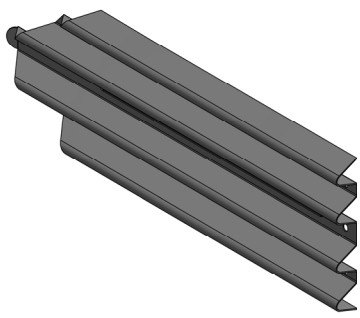
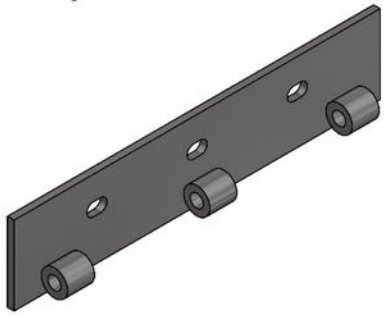
System Components

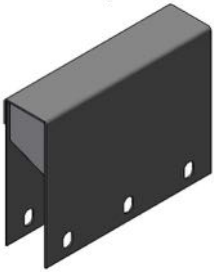

Below is a list of system components that may be used in your particular QuadGuard® Elite M10 Wide configuration. Verify parts delivered and system details with the BOM (Bill of Materials) and system drawings shipped with your system. Please call Valtir if you have any system questions (p. 3).

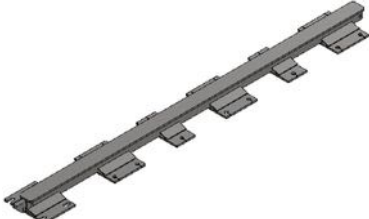

Note: Components are not shown to scale.



<p>Tension Strut Backup 69"</p>  <p>627531</p>		<p>Diaphragm Assembly, QG Elite M10</p>  <p>619120 - Varies</p>	
<p>Panel, Side, QG, Wide</p>  <p>611900</p>	<p>Panel, Fender, QG</p>  <p>611832</p>	<p>Hinge Plate, Fender Panel</p>  <p>610172</p>	
<p>Extension, Backup, M10, QGE</p>  <p>618536</p>	<p>Extension, Diaphragm, Angle</p>  <p>618526</p>	<p>Monorail Guide</p>  <p>611368</p>	

<p>Monorail, One Bay, QG</p> 	<p>Monorail, Three Bays, QG</p> 	<p>End Cap, Monorail, QG</p> 
611370	611379	608136

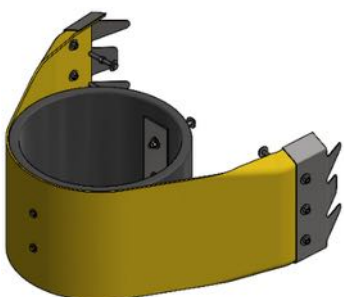
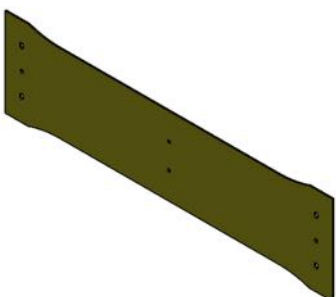
<p>Flt St 3/16X2X13, W/ Holes</p> 	<p>Die Spring, 1 1/2 ODX3/4X6</p> 	<p>Mushroom Washer</p> 
618652	117458	617045

<p>Clamp, Nose Belt</p> 	<p>Nose Cylinder Plate</p> 
606330	612253

<p>Belt Nose Assy QGE, 69</p> 	<p>Nose Belt</p> 	<p>Hit Indicator Assembly</p> 
618870	605108	610237

<p>Washer, 1/4X1</p> 	<p>Washer, Flat 1/2X1 3/8</p> 	<p>Washer, Flat, 5/8X1 3/4</p> 
118013	118009	003300

<p>Washer, Flat, 3/4X2</p>  <p>118027</p>	<p>Washer, Lock, 3/8</p>  <p>118092</p>	<p>Washer, Lock 1/2</p>  <p>118082</p>
<p>Washer, Lock, 5/8</p>  <p>118100</p>	<p>Washer, Lock, 3/4</p>  <p>118089</p>	<p>Nut, Hex 3/8, G2</p>  <p>115960</p>
<p>Nut, Hex 1/2</p>  <p>115939</p>	<p>Rail Nut, Hex, 5/8</p>  <p>003340</p>	<p>Nut, Hex, 5/8, A563A</p>  <p>003354</p>
<p>Nut, Heavy Hex, 3/4</p>  <p>003704</p>	<p>Screw, HWH, 1/4X1, Tap</p>  <p>116891</p>	<p>Bolt, Hex, 3/8X3 1/2, AT, G5</p>  <p>113612</p>
<p>Bolt, Hex, 1/2X1, G5</p>  <p>113467</p>	<p>Bolt, Hex 1/2X3, G2</p>  <p>113476</p>	<p>Rail Bolt, 5/8X2, A307</p>  <p>003400</p>

<p>Bolt, Hex, 5/8X3 1/2, G5</p> 	<p>Bolt, Hex, 5/8X4, G5</p> 	<p>Bolt, Hex, 5/8X5", G5</p> 
<p>113660</p>	<p>113666</p>	<p>113667</p>
<p>Flat Screw 5/8X8 1/2,G8</p> 	<p>Bolt, Hex 5/8X9 A325</p> 	<p>Bolt, Hex, 3/4X2, G8</p> 
<p>116879</p>	<p>004489</p>	<p>113555</p>
<p>Bolt, Hex,3/4X5,G5,G</p> 	<p>Stud, 3/4X6 1/2, G5</p> 	<p>Stud, 3/4X7, G5</p> 
<p>113573</p>	<p>117540</p>	<p>117542</p>
<p>Cylinder Nose, HDPE, 28X20</p> 	<p>Cylinder ME1 MASH</p> 	<p>Cylinder ME2 MASH</p> 
<p>606689</p>	<p>618538</p>	<p>618649</p>
<p>Cylinder Assy ME3 MASH</p> 	<p>Cylinder Segment, 18X9 1/2</p> 	<p>Tel 1 3/4X1 3/4X12GA, G, 10"</p> 
<p>618702</p>	<p>627504</p>	<p>615756</p>

Adhesive, HY200, Hilti 	Anchor Kit, Hilti 3/4X7 	Tel 2X2X12GA, H2S, G, 10" 
118710	619316	615765

Select Transition



Important: A proper Transition Panel or Side Panel must be used on each side of the Backup. A Side Panel is not needed when a Transition Panel is used. Several types of transitions are available for use with the QuadGuard® Elite M10 Wide (Figures 1 – 6). The correct Panel(s) to use will depend on the direction of traffic and what type of barrier or road feature the QuadGuard® Elite M10 Wide is shielding. Contact Customer Service for any transition questions (p. 3).

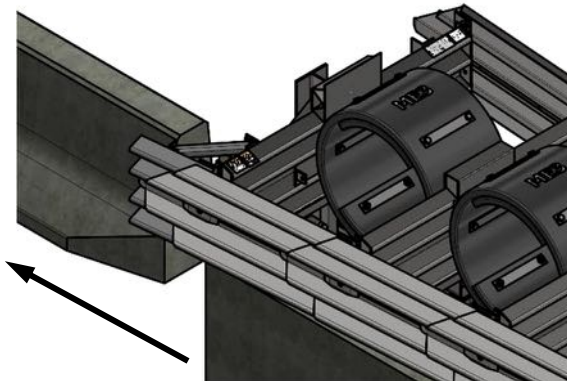

Figure 1
No Transition
(Unidirectional only)

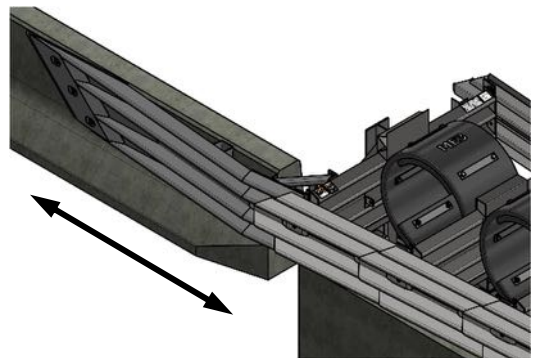

Figure 2
Safety Shape Barrier

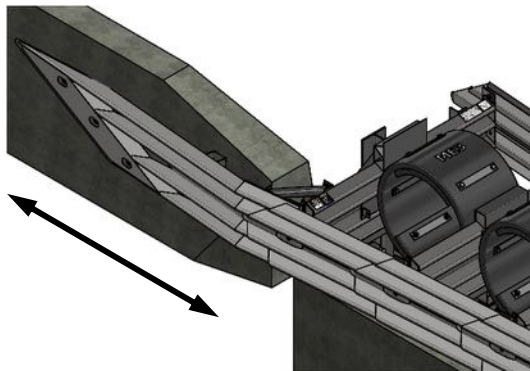

Figure 3
Single Slope Offset

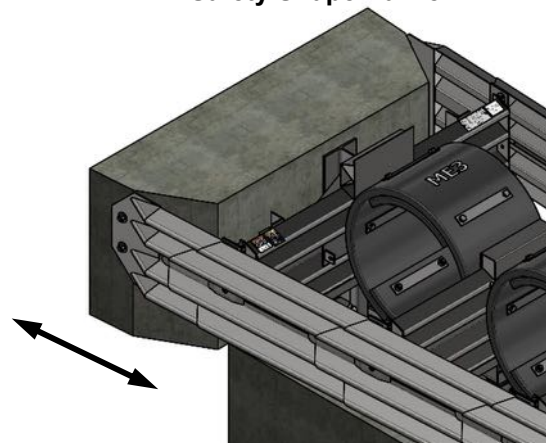

Figure 4
Vertical Barrier

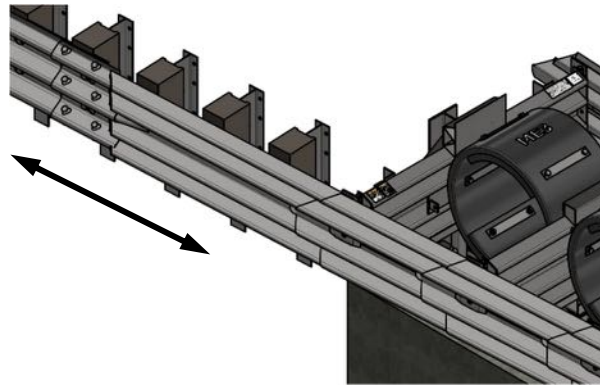

Figure 5
Quad to Thrie-Beam

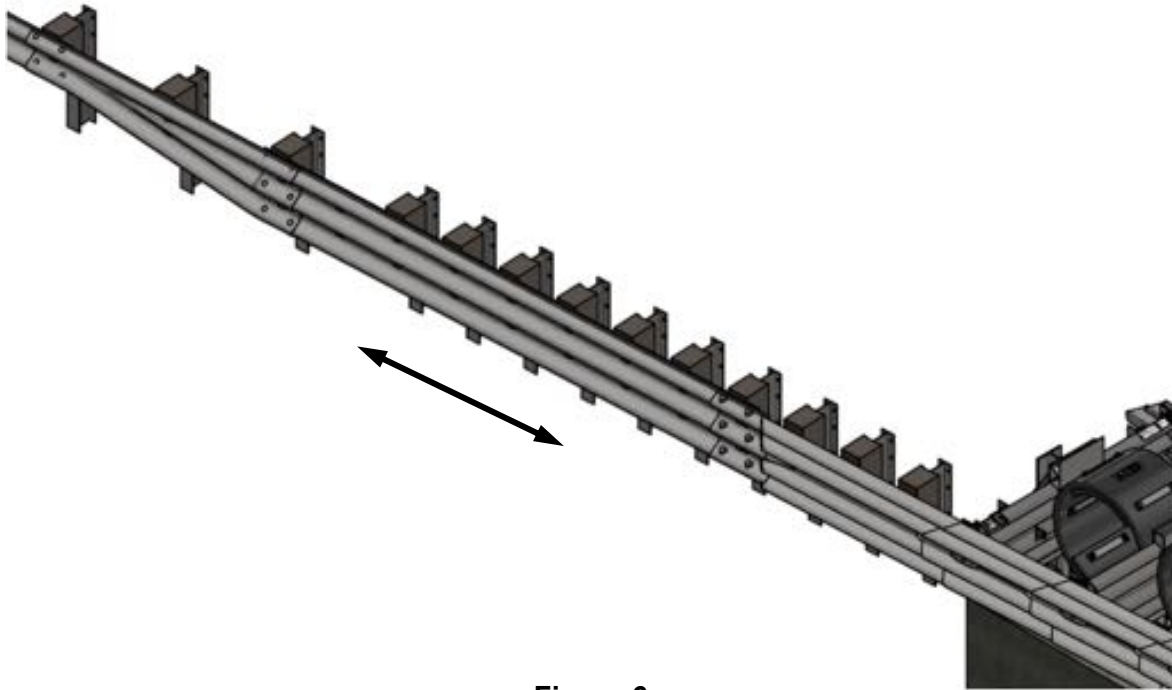

Figure 6
Quad to W-Beam Guardrail

Recommend Tools

Documentation

- Manufacturer's Assembly Manual
- Manufacturer's Drawing Package

Personal Protective equipment

- Eye Protection
- Gloves
- Safety Toe Shoes

Cutting equipment

- Rotary Hammer Drill
- Rebar cutting bit
- Concrete drill (Double Fluted*) bits –7/8" [22 mm]
- Grinder, Hacksaw or Torch (optional)
- Drill motor
- Drill bits 1/16" through 7/8"



Important: Valtir recommends using Double Fluted drills to achieve required tensile strength when assembling the approved anchoring system.

Hammers

- Sledgehammer
- Standard hammer

Wrenches

- Heavy duty impact wrench
- Standard adjustable wrench
- 1/2" drive Sockets: 9/16", 11/16", 3/4", 15/16", 1 1/8", 1 1/4"
- 1/2" drive Deep Sockets: 15/16", 1 1/4"
- 1/2" drive Ratchet and attachments
- 1/2" drive Breaker Bar - 24" long
- 1/2" drive Torque Wrench: 200 ft.-lbf.
- Crescent Wrench: 12" [300 mm]
- Allen Wrench: 3/8"
- Impact Wrench: 1/2"

Miscellaneous

- Traffic control equipment
- Lifting and moving equipment - Minimum 5,000 lb. capacity required
- Air Compressor (100 psi) and Generator (5 kW)
- Pry bar
- Drift pin 300 mm [12"]
- Center punch
- Tape measure 25' [7.5 m]
- Chalk line
- Concrete marking pencil
- Nylon bottle brush for cleaning 7/8" drilled holes
- Rags, water, and solvent for touch-up
- Chain, 3/8" grade 40, 20' [6 m] with 1/2" [13 mm] hooks
- Acetylene torch

Note: The above list of tools is a general recommendation and should not be considered a complete list. Depending on specific site conditions and the complexity of the assembly specified by the appropriate highway authority, the required tools may vary. Decisions as to what tools are needed to perform the job are entirely within the discretion of the specifying highway authority and the authority's selected contractor performing the assembly of the system at the authority's specified assembly site.

Site Preparation/Foundation

A QuadGuard® Elite M10 Wide should be assembled only on an existing or freshly placed and cured concrete foundation (4000 psi [28 MPa] minimum). Location and orientation of the concrete base and attenuator must comply with project plans or as otherwise determined by the resident project engineer.

Recommended dimension and reinforcement specifications for new concrete foundations are provided in Valtir Concrete Foundation drawing, supplied with the system. The system may be assembled on a non-reinforced concrete roadway (minimum 8" [203 mm] thick). Assembly cross-slope shall not exceed 8% and should not twist more than 2% over the length of the system; the foundation surface shall have a light broom finish.

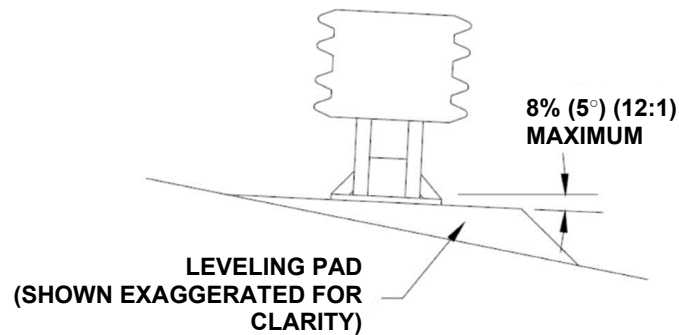

Figure 7
Cross-Slope



Caution: Accurate placement of all steel rebar is critical to avoid interference with the concrete anchor bolts.



Warning: Location of the Backup in relation to nearby objects will affect the operation of the attenuator. Upon impact, the Fender Panels telescope rearward and extend beyond the rigid Backup as much as 25" [635 mm]. Position the Backup so that the rear ends of the last Fender Panels are a minimum of 25" [635 mm] forward of objects that would otherwise interfere with movement of the rearmost Fender Panels. Failure to comply with this requirement is likely to result in system performance which has not been crash tested pursuant to MASH criteria and may also cause component damage which will necessitate maintenance or replacement of the system.



Warning: It is the responsibility of the installer to ensure proper site grading for the QuadGuard® Elite M10 Wide as directed by the state or specifying agency pursuant to the AASHTO Roadside Design Guide.

Foundation/Anchoring



Warning: It is the responsibility of the local DOT or appropriate highway authority to ensure that this assembly conforms to the AASHTO Roadside Design Guide.



Warning: It is the responsibility of the installer to ensure that your assembly procedure meets all appropriate Occupational Safety and Health Administration (“OSHA”) and local standards.

Asphalt Installations



Warning: QuadGuard® Elite M10 Wide has not been tested on asphalt.

Concrete Installations

Recommended dimension and reinforcement specifications for new concrete pads can be found on the standard drawings.

The QuadGuard® Elite M10 69” may be installed on any of the following foundations using the specified anchorage:

Foundation A: Reinforced Concrete Pad or Roadway

Foundation: 6” [152 mm] (reinforced) **with Anchor Block** minimum thickness P.C.C.

Anchorage: Approved adhesive with 7” [178 mm] studs 5 1/2” [140 mm] embedment

Foundation B: Reinforced or Non-Reinforced Concrete Pad or Roadway

Foundation: 8” [203 mm] minimum thickness P.C.C.



Important: To prevent sliding during impact, the pad must be placed against or tied to an existing structure. Additional below grade supports may also be necessary as the project engineer directs.)

Anchorage: Approved adhesive with 7” [178 mm] studs 5 1/2” [140 mm] embedment

Valtir Approved Adhesive Anchoring System

A Valtir approved adhesive anchoring system is required to securely anchor crash cushions. Each approved adhesive kit contains adhesive, studs, nuts and washers. Both vertical and horizontal assemblies are possible using an approved adhesive anchoring system.

Vertical Anchors

Note: Read all Valtir approved adhesive instructions before starting.

1) Prepare the Concrete Foundation



Warning: Do not allow anchoring adhesive to contact skin or eyes. See material safety data sheet supplied with adhesive kit for first-aid procedures. Use only in well-ventilated area. Do not use near open flame.



Warning: It is the responsibility of the installer to maintain a safe work area including the use of standard work zone safety equipment & PPE: gloves, safety-toe shoes, and eye / ear protection.

The anchor bolts (studs) that anchor the QuadGuard® Elite M10 Wide Backup and/or Monorail sections to the concrete foundation must be those shipped in the kit or of high strength steel (120,000 psi [830 MPa] minimum tensile strength or equal). These studs must be set in minimum 4000 psi [28 MPa] concrete. Allow the concrete to cure a minimum of seven days before applying anchoring adhesive.

2) Drill Boreholes



Caution: It is the responsibility of the installer to consult OSHA silica respiratory standard 29 CFR 1910.134 for debris removal from borehole(s) and use Valtir approved adhesive to achieve optimum tensile strength. Do not use diamond drill bits for drilling boreholes.

Use the Monorail(s) and Tension Strut Backup as drilling templates. Use a rotary hammer drill to drill the boreholes 7/8" [22 mm] diameter to the recommended depth. See the approved adhesive instructions provided with adhesive kit. Check ensure each borehole is drilled to the proper depth and aligned with the part to be anchored per Anchoring Information table.

Anchor Information					
Stud Size:	Orientation	Bit Size	Minimum Depth	Torque	Medium
3/4X6 1/2"	Horizontal	7/8" [22 mm]	5 1/4" [133 mm]	Adhesive Manufacturer's Spec	Concrete
3/4X7"	Vertical	7/8" [22 mm]	5 3/4" [146 mm]	Adhesive Manufacturer's Spec	Concrete

3) Clean the Boreholes

Blow the concrete dust from the borehole using (90 psi) oil-free compressed air. Thoroughly brush the borehole with a 7/8" diameter steel bristle tube brush and then blow it out again. If the borehole is wet, completely flush it with water while brushing and then blow it clean to remove all water using oil-free compressed air.

Note: Use of the Valtir approved vacuum drilling equipment is authorized to replace the blowing and brushing requirement of Step 3.

4) Apply Approved Adhesive

Fill the borehole 100% full.



Caution: Fill borehole 100% full so it is even with the pavement surface per the adhesive manufacturer's instructions.

5) Add the Washers and Nuts

Place a flat washer onto the stud then thread a nut on until the end of the stud is flush with the nut (Figure 8).

6) Insert Studs in Boreholes and Wait for Adhesive to Cure

Push the stud down through the part to be anchored and into the borehole.



Warning: Do not disturb or load the stud until the approved adhesive material has fully cured (reference instructions supplied with the approved adhesive kit).

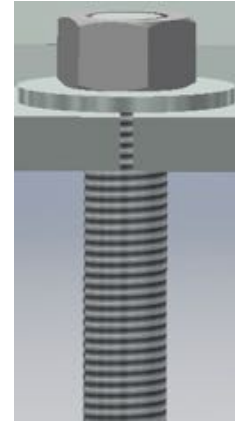

Figure 8
Anchor Application
(Before Applied Torque)

7) Torque the Nuts

Once the adhesive has fully cured, torque the nut to the adhesive manufacturer's recommended values.

Steel Rebar Anchor Assembly Cautions

If steel rebar is encountered while drilling an anchor bolt borehole, apply one of the following solutions:

A) Use a rebar drill bit for the rebar only and then switch back to the concrete bit to finish drilling into the underlying concrete until the proper borehole depth is reached.



Caution: Do not drill through rebar without first obtaining permission to do so from the project engineer.

B) Drill a new borehole down at an angle past the rebar to the proper depth. Anchor the stud by completely filling both boreholes with an approved adhesive.

Horizontal Anchors

The horizontal approved adhesive kit is the same as the vertical kit.



Caution: Fill borehole 100% full so it is even with the vertical concrete surface per manufacturer's instructions.

1) Follow the instructions supplied with your approved adhesive kit

Apply approved adhesive to each anchor per instructions.

2) Add the Washers and Nuts

Put washer and nut on stud so the **nut is flush with end of stud**.

3) Insert each Stud with Washer and Nut into Borehole

Push stud with washer and nut into borehole.



Important: The stud should be flush with the top of the nut in both **vertical** and **horizontal** applications prior to tightening (Figure 9).

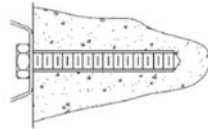

CORRECT

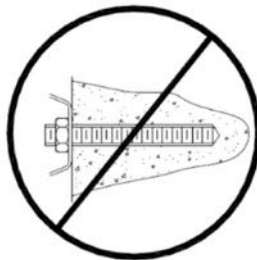

INCORRECT

Figure 9
Horizontal Application
(Before Applied Torque)



Caution: Do not disturb or load the stud until the approved adhesive material has hardened (reference approved adhesive kit instructions for hardening times).

4) Torque the nuts

Once the adhesive has fully cured, torque nut(s) to the approved adhesive manufacturer's specification.

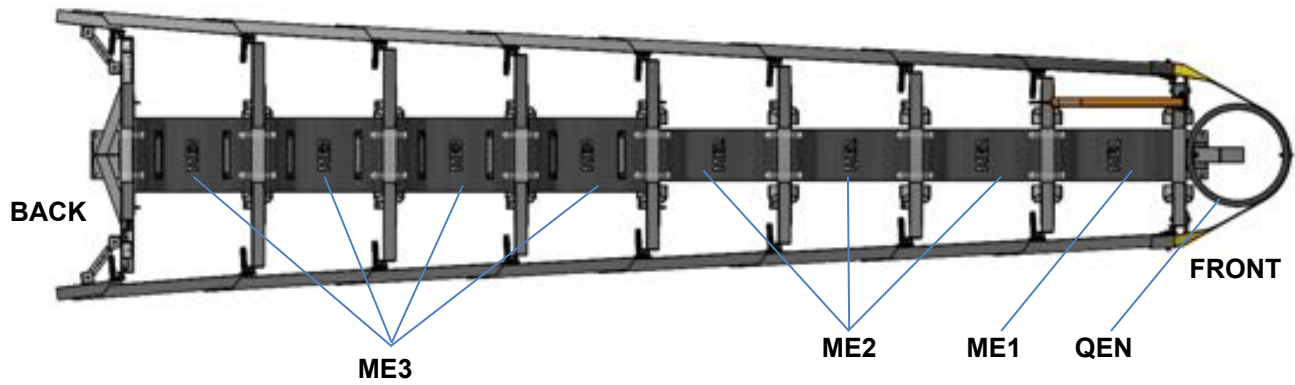

Figure 10 Plan View

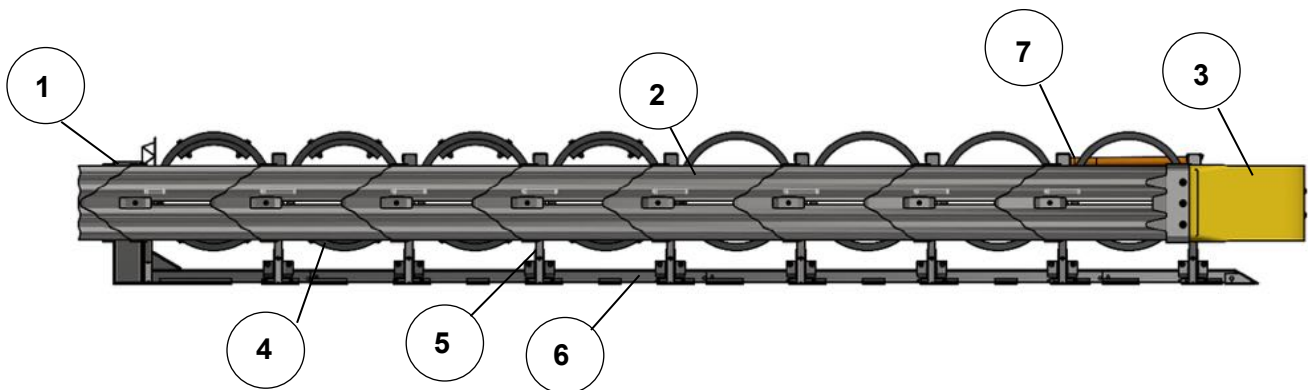

Figure 11 Elevation View

KEY

- 1) Backup
- 2) Quad-Beam Fender Panel
- 3) Belt Nose
- 4) Cylinder
- 5) Diaphragm
- 6) Monorail
- 7) Hit Indicator

How to Determine Left/Right

To determine left from right when ordering parts, stand in front of the system facing the hazard. Your left is the system's left and your right is the system's right.

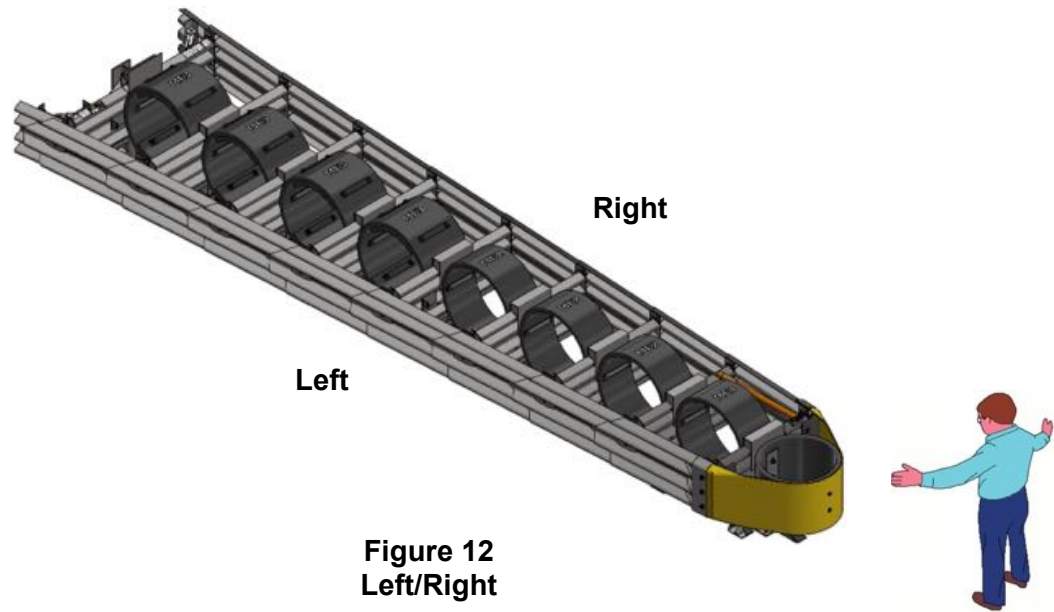

Figure 12
Left/Right

Counting the Number of Bays

One Bay consists of one Diaphragm, two Fender Panels, etc. The Nose Assembly is not considered a Bay (Figure 13).

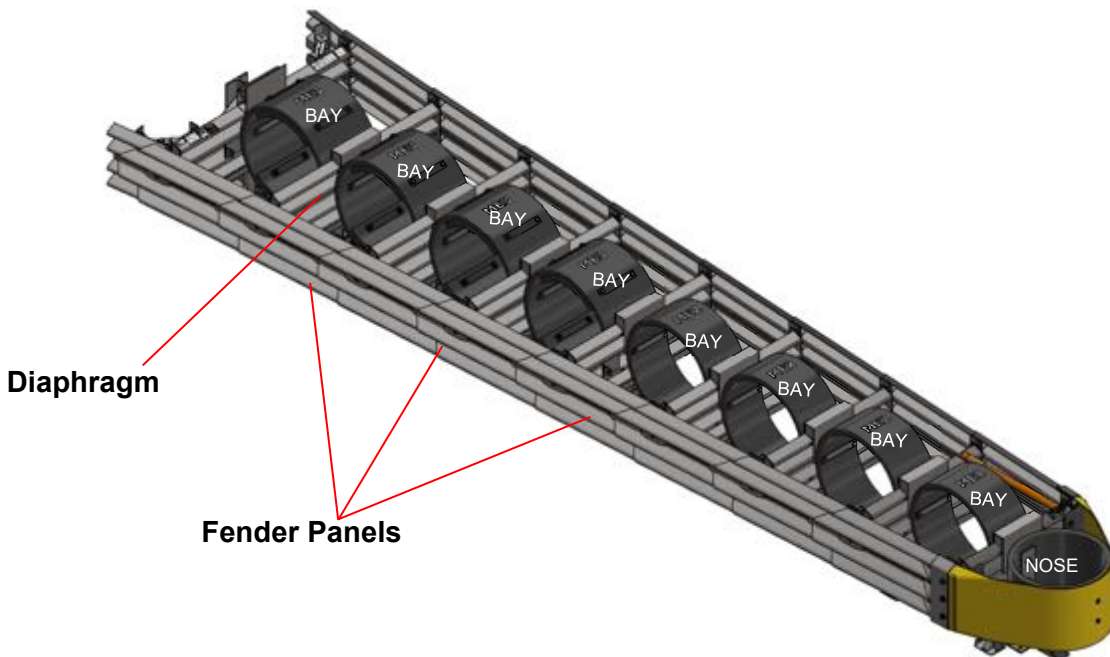

Figure 13
Number of Bays (8 Bay System Shown)

QuadGuard® Elite M10 System Chart	
Width	8 Bay - 62 mph [100 kph]
69" [1,753 mm]	QM10069E

The nominal width of the **Tension Strut Backup** is the width between Side panels behind the Backup (Figure 14). The outside width of the system is approximately 6" [152 mm] to 9" [229 mm] wider than this measurement. The width of the system is not the same as the width of the Backup.



Figure 14
Width of System with Tension Strut Backup

System Assembly

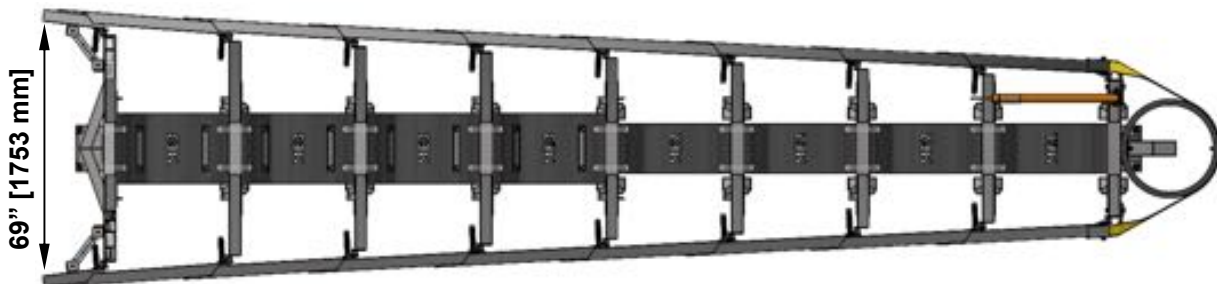

Figure 15

Note: The Drawing Package supplied with the QuadGuard® Elite M10 Wide must be used with these instructions for proper assembly and should take precedence over these general instructions.

1) Determine Transition Type with Tension Strut Backup

The QuadGuard® Elite M10 Wide uses a Tension Strut Backup.

A Transition Panel or Side Panel must be used on each side of the Backup. A Side Panel is not needed when a Transition Panel is used. Several types of transitions are available for use with the QuadGuard® Elite M10 Wide.

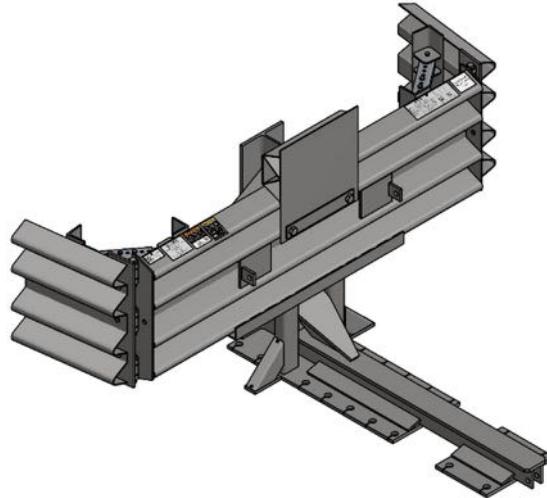

Figure 16
Tension Strut Backup

- A. Locate the centerline of the system by measuring the proper offset from the hazard. See the drawing package supplied with the system.
- B. Mark the centerline of the system with a chalk line.
- C. Mark a construction line parallel to the center line and offset 6.5" [165 mm] to one side as shown in Figure 17.
- D. The edge of the Monorail will be placed on this line.

Note: The concrete pad must comply with the manufacturer's drawing package supplied with the system.



Warning: Only Strong Soil, AASHTO M147 with static performance >90% is to be used with the assembly of a transition in soil.



Warning: Location of system with respect to the hazard is critical and dependent on the type of Transition Panel used. See the project plans supplied with the system for details.

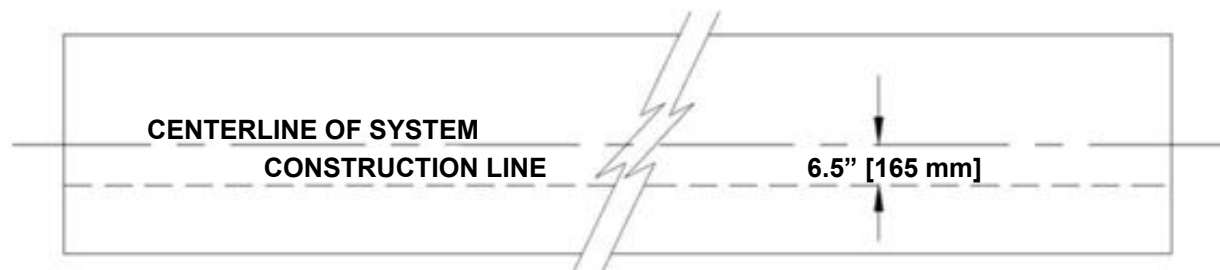

Figure 17
(Top view of concrete pad)
Locating Construction Line

2) Anchor the Backup and Monorail

See Figure 18 (showing Backup Assembly) and Figure 20 (showing Monorail deployment). Also refer to the drawing package and the approved anchoring instructions (p. 16).



Warning: Location of the system is critical and dependent on the type of Transition Panel used. Consult project plans supplied by the applicable highway authority with the system for details.

Step 1. Tension Strut Backup Assembly (Figure 18)

Locate the Backup and Monorail on the pad with the side of the Monorail on the construction line (Figure 20). Verify that applicable Transition Panels fit properly before anchoring the Backup. Drill 7/8" [22mm] diameter by 5 3/4" [146 mm] deep anchor holes in the pad using the Backup as a template. Do not drill through pad. Anchor the Backup to the concrete pad using approved adhesive kits (p. 16).

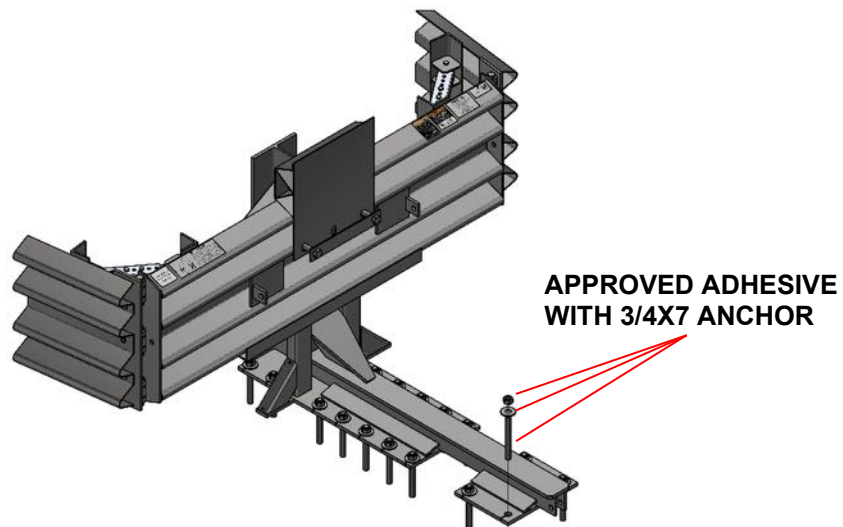

Figure 18
Anchoring Tension Strut Backup to Foundation

Step 2. Monorail Assembly

Locate the Monorail on the construction line as shown in the Monorail Assembly drawings. Drill 7/8" [22mm] diameter by 5 3/4" [146 mm] deep anchor holes using the Monorail as a template (Figure 20). Do not drill through the pad. Anchor each Monorail section using the provided approved adhesive kits (p. 16). It is important to attach each segment of Monorail in alignment from the back to the front of the system ($\pm 1/4$ " [6 mm]).



Warning: Improper alignment at the Monorail Splice Joints will prevent proper system collapse during an impact.



Warning: Every hole and slot in Backup and Monorail must have an approved adhesive stud anchoring it.

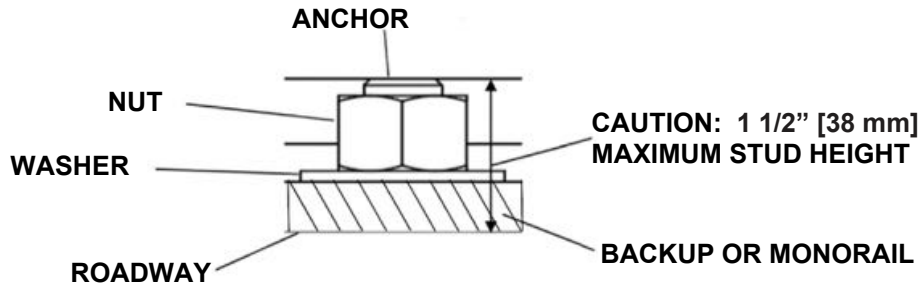

Figure 19
Proper Stud Height

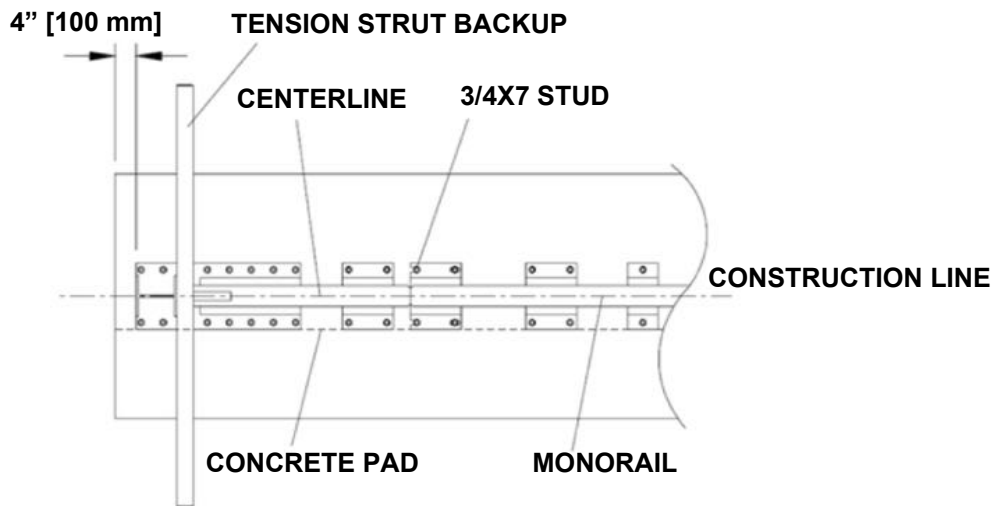

Figure 20
Backup and Monorail Placement for Tension Strut Backup

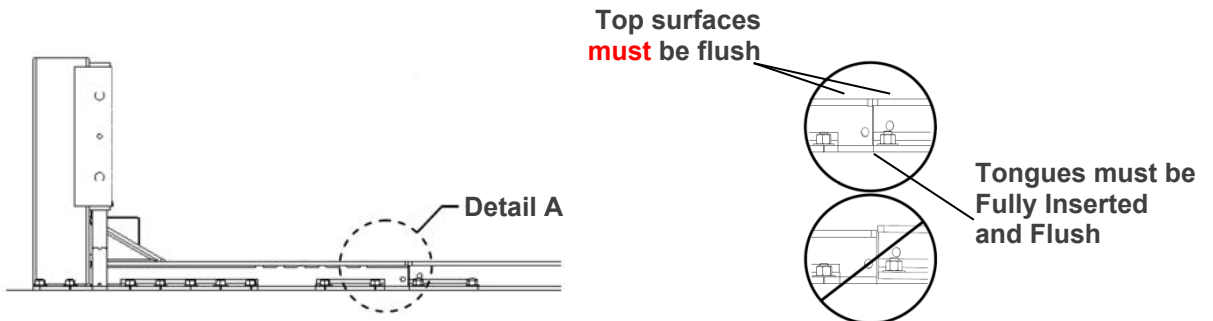

Figure 21
Rail Height and Alignment

Detail A

3) Attach Side Panels / Transition Panels to Backup Assembly

Attach the Transition Panel or Side Panel as appropriate to each side of the Backup. Refer to Figure 22 and the drawing package for more information.

Note: A Side Panel is not needed when a Transition Panel is used.

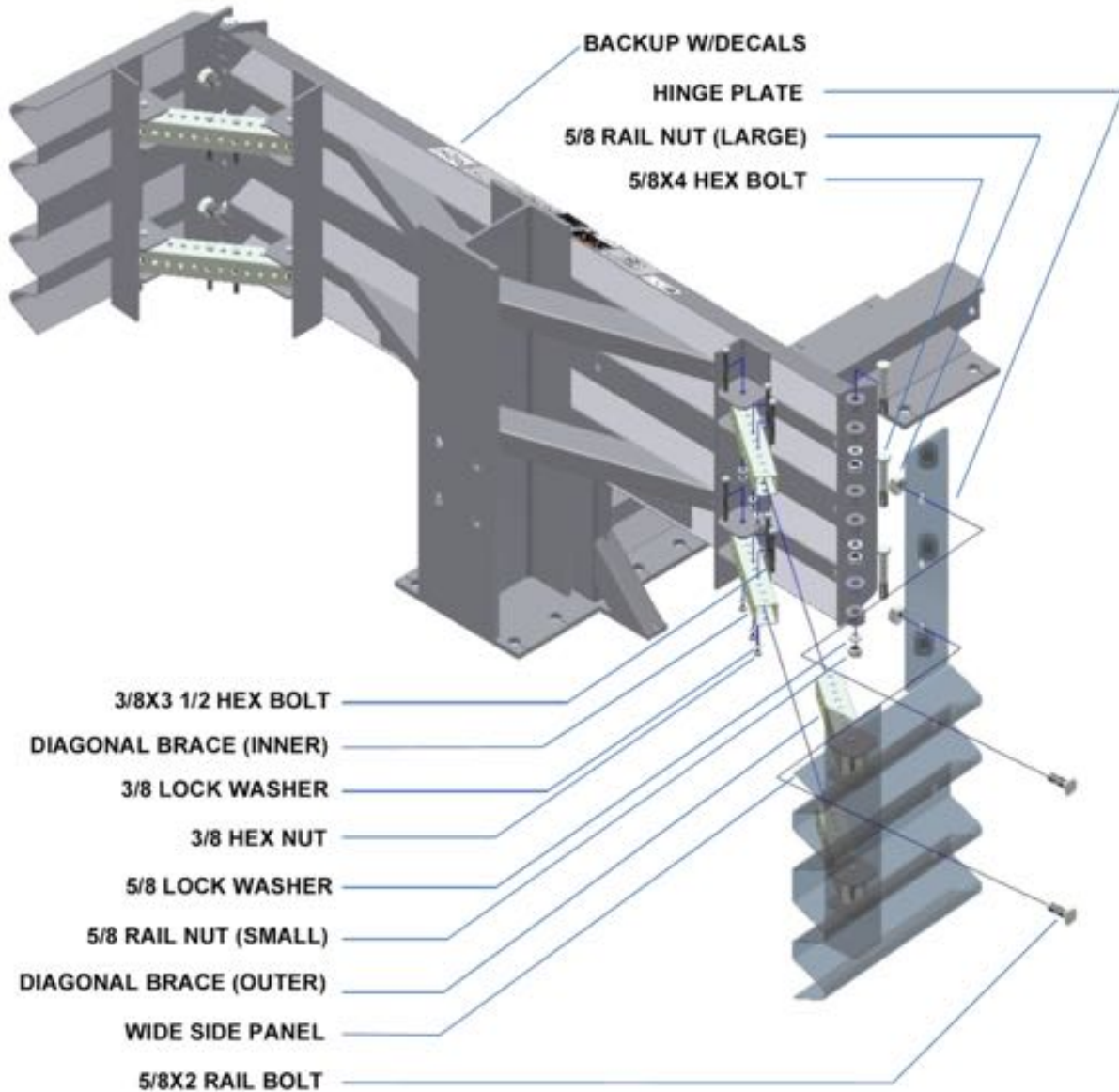

Figure 22
Side Panel/Transition Panel Attachment

4) Attach Monorail Guides

Attach Monorail Guides to Diaphragms as shown in Figure 23, and the Diaphragm Assembly drawing (p. 49).

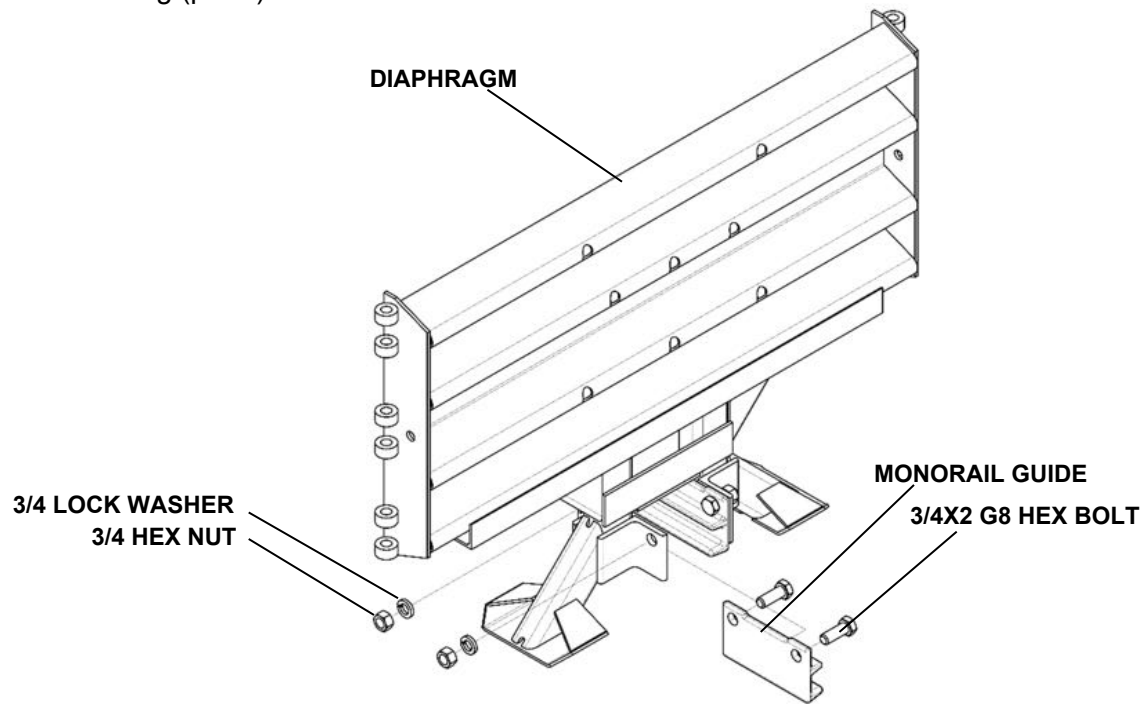

Figure 23
Monorail Guide Attachment One Side

5) Deploy Diaphragms

Orient a Diaphragm so that the front face of the Quad-Beam shape faces toward the Nose of the system as shown in Figure 24. Slide one Diaphragm all the way to the Backup to ensure the system is able to collapse properly during impact. Once this has been verified, slide the Diaphragm forward to approximately 32" [813 mm] in front of the Backup. Orient and slide all Diaphragms onto Monorail and position each approximately as shown below (Figure 25).

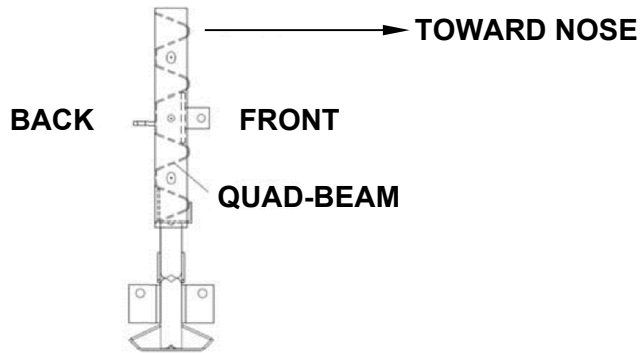

Figure 24
Diaphragm Orientation

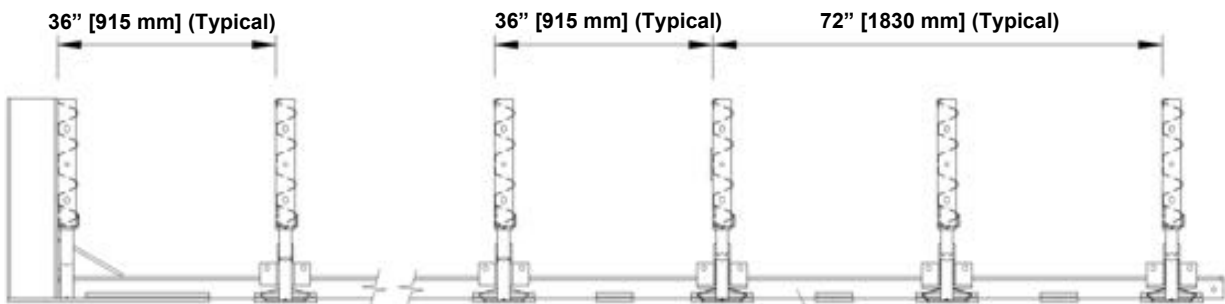

Figure 25
Diaphragm spacing

6) Attach End Cap

Attach End Cap to the Monorail as shown in Figure 26 and the Monorail Assembly drawing.

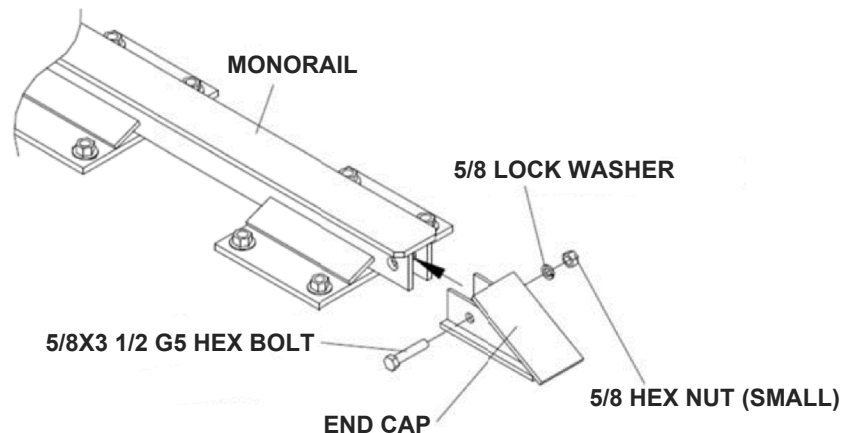

Figure 26
End Cap Attachment

7) Cylinder Attachment

All QuadGuard® Elite M10 Wide systems utilize three Cylinder types. Bay 1 contains a Cylinder with ME1 stenciled on the outer surface. The Nose Assembly contains a single walled 28" outside diameter Cylinder with QEN stenciled on the surface. All remaining Bays have Cylinders with ME2 or ME3 stenciled on the outer surface.



Warning: Placing the wrong Cylinder in the nose or any Bay may result in unaccepted crash performance as described in MASH.

8) Attach Rear Most ME3 Cylinder

With Backup Extension in place, position a ME3 Cylinder so it is centered on the mounting holes. Fasten Cylinder to Backup using 3/4X5" hex bolts, hex nuts, and bar washers. Tighten ME3 Cylinder to Backup. Slide the next Diaphragm against the Cylinder so no gaps exist between the Backup, Cylinder, and Diaphragm. Tighten all fasteners.

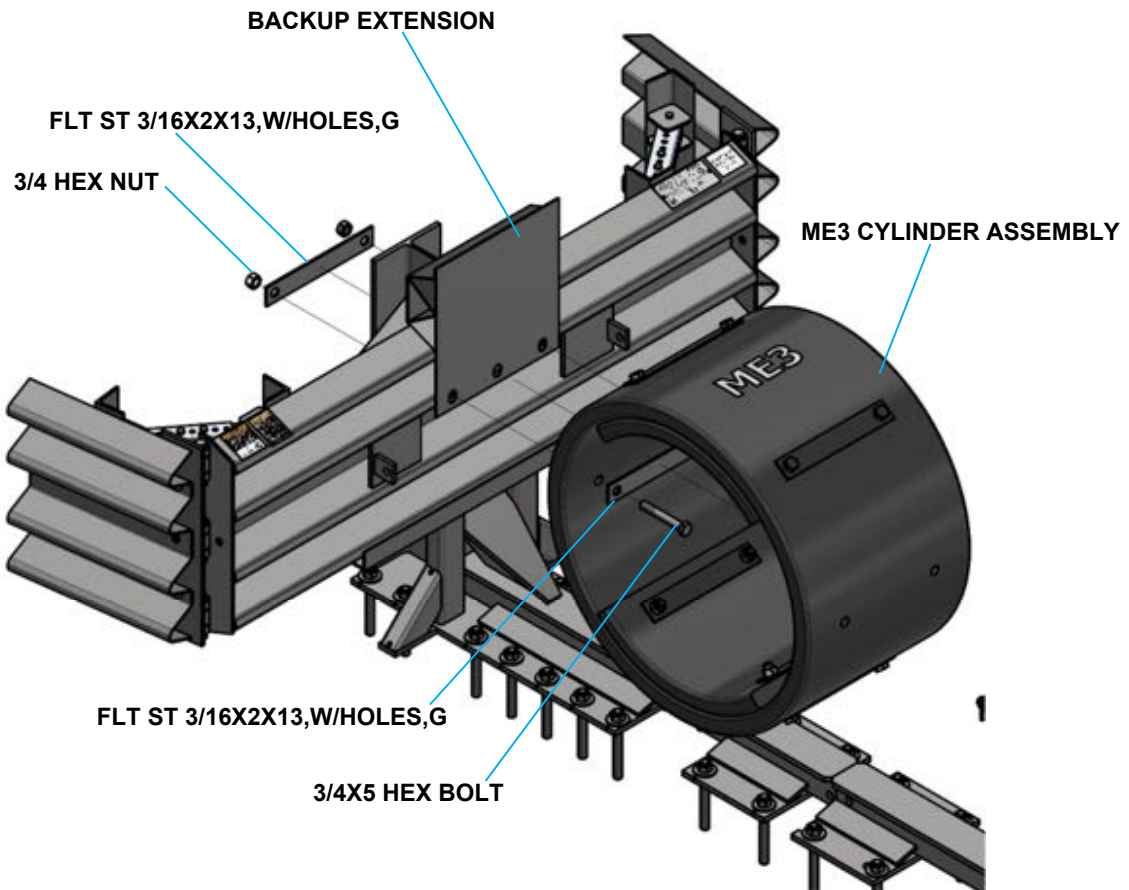

Figure 27
Typical Backup ME3 Cylinder Assembly

9) Attach Remaining ME3 Cylinders

Continue attaching the ME3 Cylinders to Diaphragms using 3/4X9" hex bolts, hex nuts and bar washers. Remove any clearance between the ME3 Cylinders and Diaphragms as you work forward from the Backup. Tighten all fasteners.



Important: Diaphragm Extensions must be in place before Cylinder attachment.

10) Attach the ME2 Cylinders

Attach ME2 Cylinders in the same way as ME3 Cylinders. Tighten all fasteners.



Important: Diaphragm Extensions must be in place before Cylinder attachment.

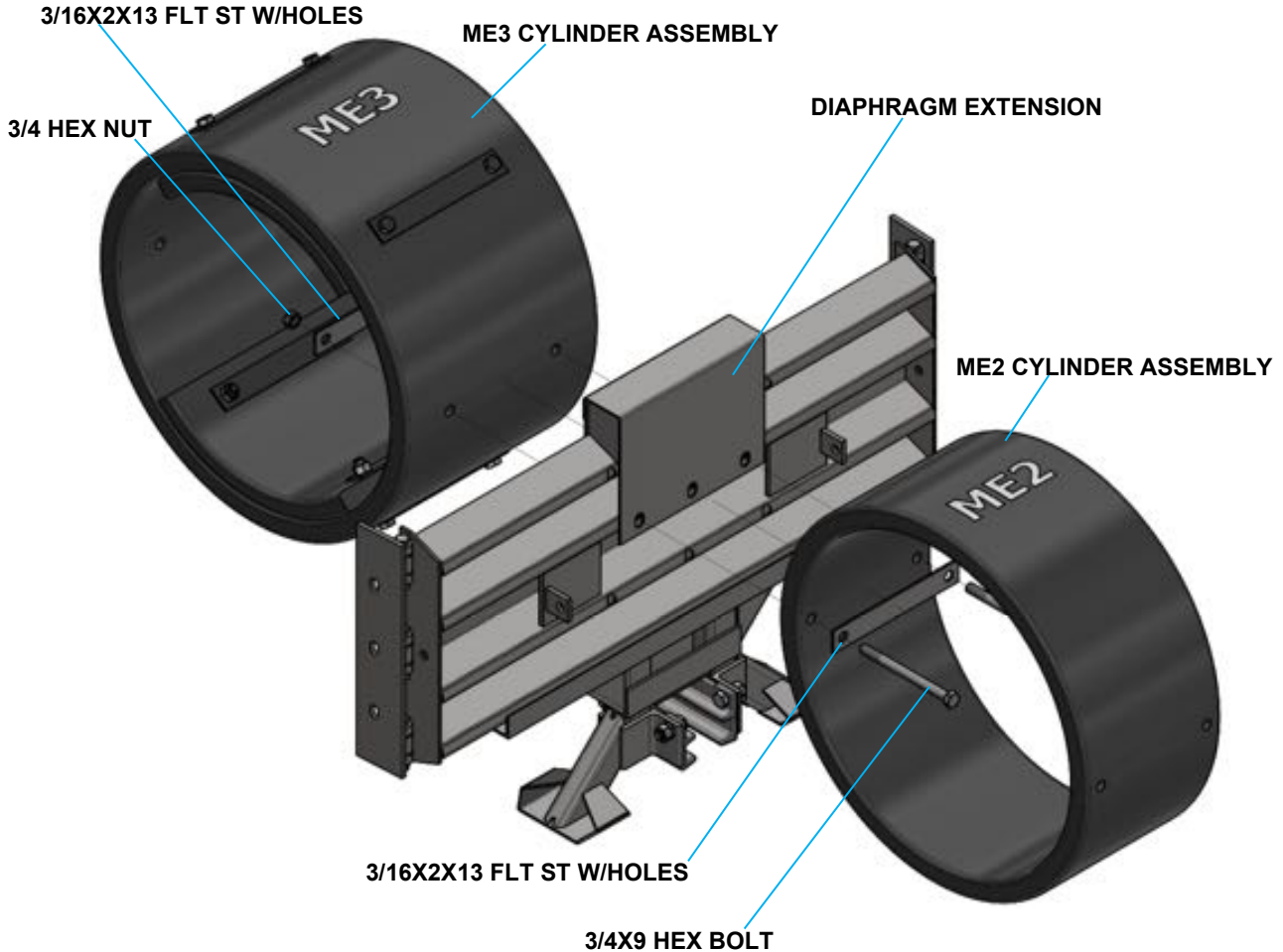

Figure 28
Typical ME3 Cylinder Mounting

11) Attach the ME1 Cylinder in Bay 1

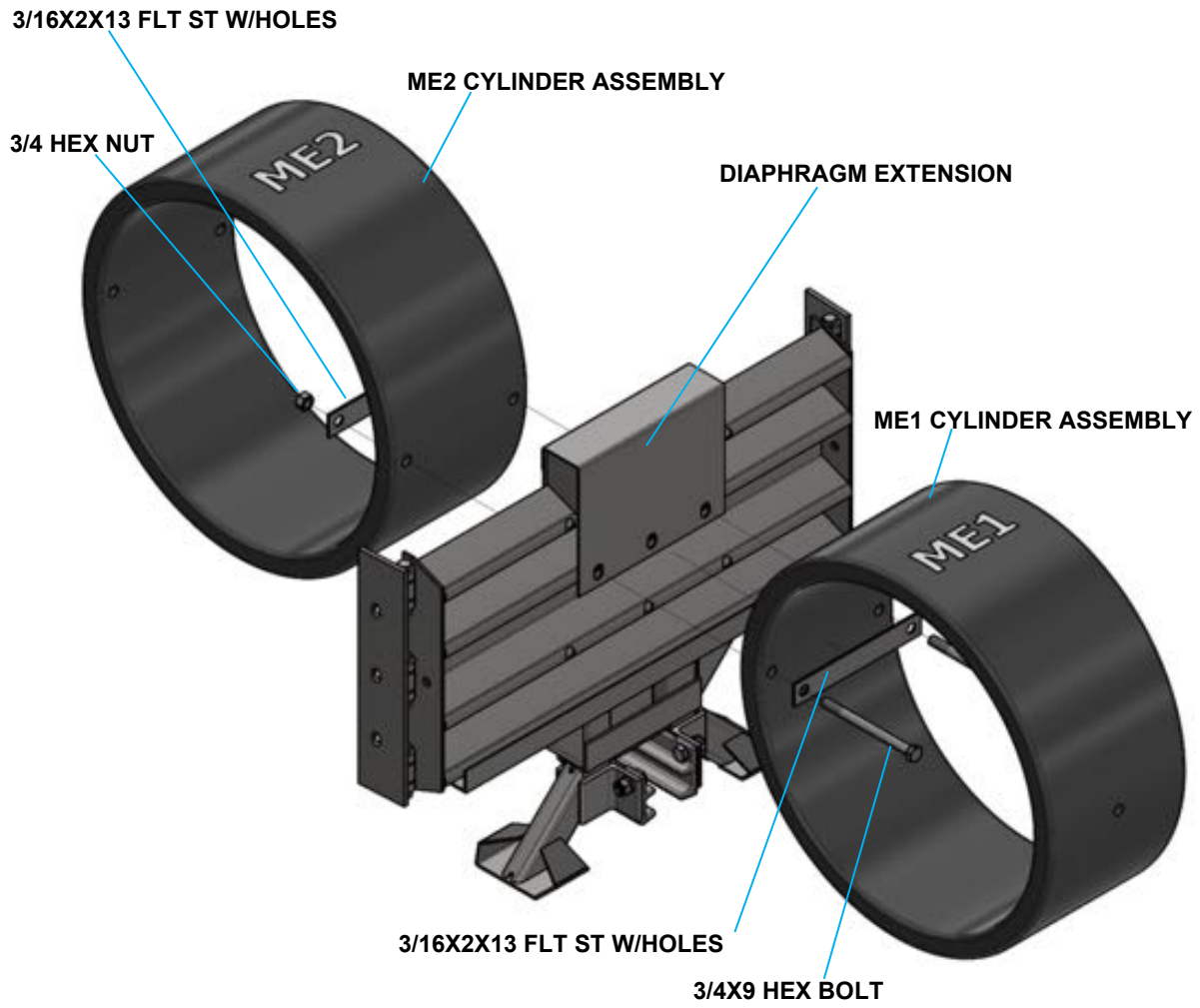

Figure 29
Typical ME1 to ME2 Mounting

12) Attach Nose Cylinder

Attach the Nose Cylinder using two 5/8" bolts rods through the Nose Cylinder Plate, Nose Cylinder, and Diaphragm (Figure 30). Secure each 5/8" hex bolt with flat washers, lock washers, and hex nuts. Tighten all fasteners.

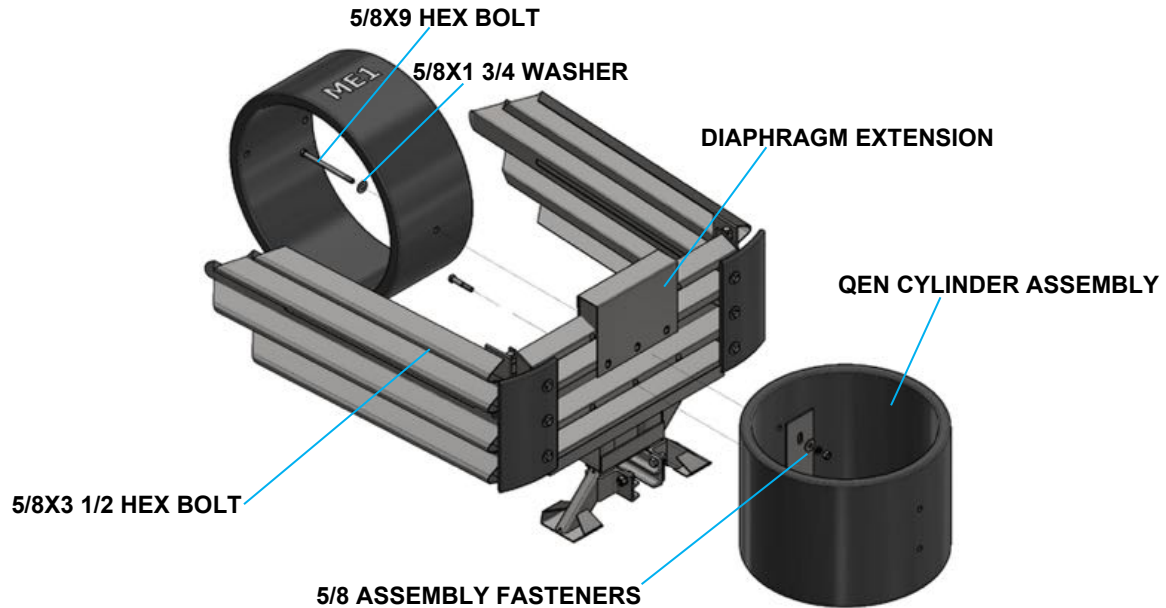

Figure 30
Attach Nose Cylinder to First Diaphragm

13) Attach Hinge Plates to Diaphragm

Orient Hinge Plate with holes rearward and hinges toward the front. Insert 5/8X4" hex bolts through all hinges. Secure each bolt with 5/8" lock washer and hex nut (Figure 31). (Typical three places per side on all Diaphragms) The First Diaphragm has additional Cylinder Segments fastened with 5/8" heavy hex nuts, flat washers and 5/8X5" hex bolts (Figure 32). See pages 48 and 49 for additional information.

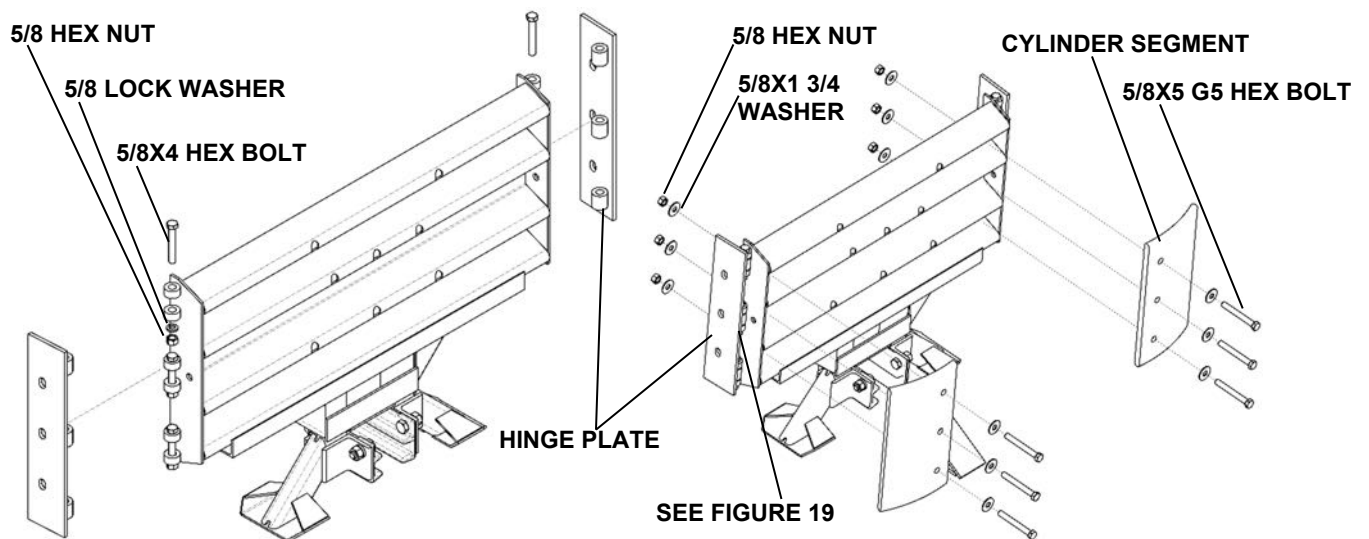

Figure 31 - Hinge Plate Diaphragms 2-6

Figure 32 - Hinge Plate 1st Diaphragm

14) Fender Panel Attachment

Starting at the Backup and working forward, assemble Left and Right Fender Panels as shown in Figure 34.

Step 1. Place the Fender Panel so that the center hole of the rearward Diaphragm is lined up with the approximate center of the slot in the Fender Panel.

Attach the Mushroom Washer Assembly as shown in Figure 35 but do not torque at this time. (This helps to balance the Fender Panel.)

Step 2. Slide the Fender Panel forward until the holes in the Fender Panel line up with the holes in the forward Diaphragm.

Step 3. Use a drift pin to align the center hole of the Fender Panel with the center hole of the Diaphragm.

Step 4. Attach the front of the Fender Panels to the next Diaphragm using two rail bolts and large rail nuts per side. Use only the top and bottom holes; leave the center hole open until the next Fender Panel is attached.

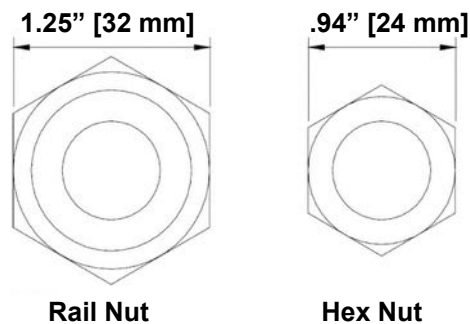

Figure 33
Rail Nuts are Oversize

Note: Do not mix the 5/8" rail nuts (large) with the 5/8" hex nuts (small) (Figure 33).

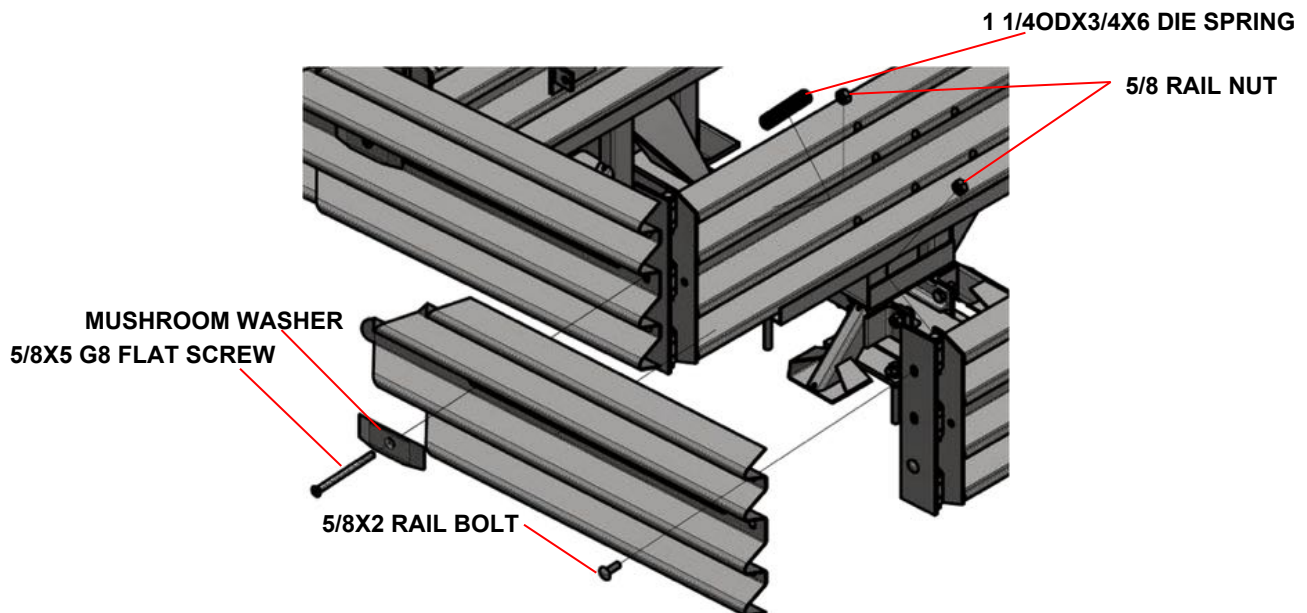

Figure 34
Fender Panel Assembly

Note: Mushroom Washers lay flat against the Fender Panel as shown below. Mushroom Washer Stand-off must be seated completely through slot (Figure 35).

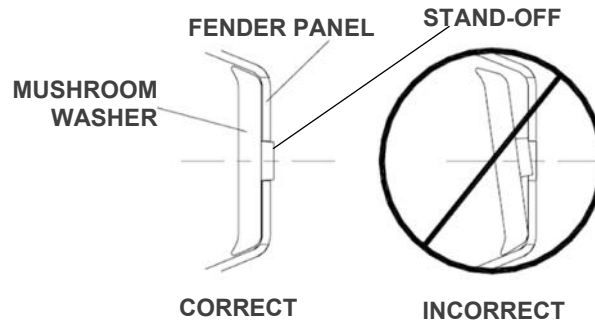

Figure 35

Continue attaching Fender Panels until you reach Diaphragm No. 1 (Figure 36).

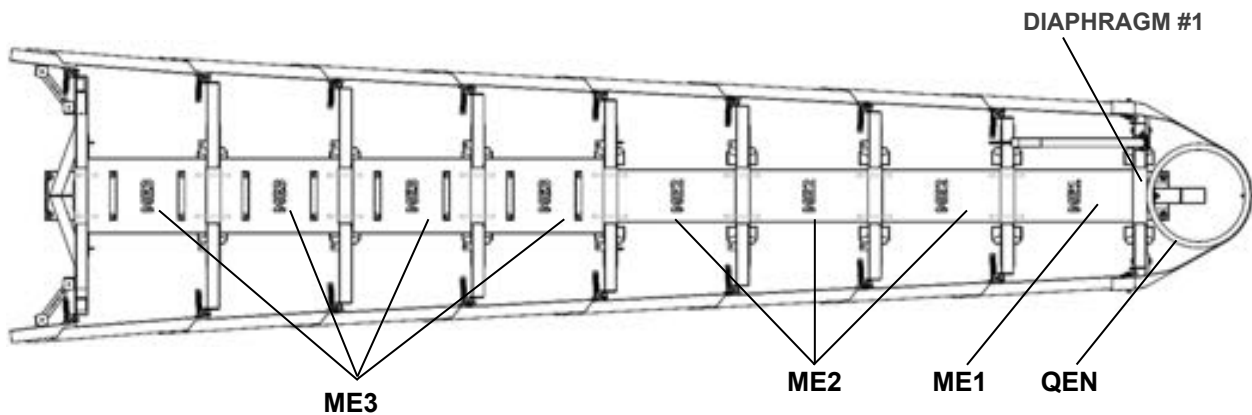

Figure 36
Diaphragm No. 1 & Cartridge Placement

15) Belt Nose Assembly

- a. Using 5/8X5" hex bolts, 5/8X1 3/4" flat washers, and 5/8" hex nuts, attach Fender Panels to Diaphragm Hinge Plates on three places per side (Figure 37 and 38). Tighten all fasteners.
- b. Thread additional 5/8" nuts onto the 5/8X5" hex bolts. Slide 5/8X1 3/4" flat washers onto bolts (three places per side). Adjust the nuts so the outside of the washers are even with the Fender Panel humps (Figure 37).
- c. Place Belt Nose over Diaphragm/Fender Panel attachment bolts.
- d. Align holes in Belt Clamps with bolts and place onto bolts against belt.
- e. Secure with 5/8X1 3/4" washers and 5/8" hex nuts in three places per side. Adjust Belt Nose Assembly so belt height is 32.0" above grade. Tighten all fasteners.
- f. Complete Belt Nose Assembly by attaching Belt to Nose Cylinder with 1/2X3" hex bolt, 1/2" washer, lock washer, and hex nut.

The Nose can be delineated to comply with local codes (chevron, reflectorized sign, etc.).



Warning: Placing the wrong type Cylinder in the Nose or any Bay will result in unacceptable crash performance as described in MASH.

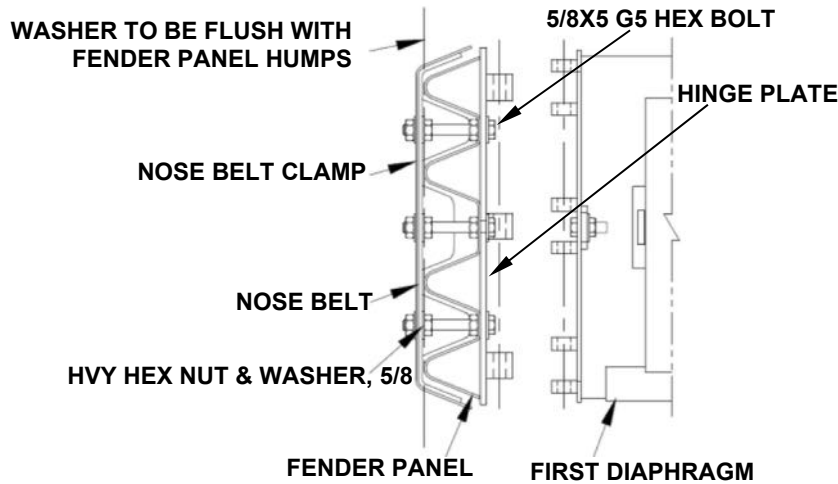

Figure 37

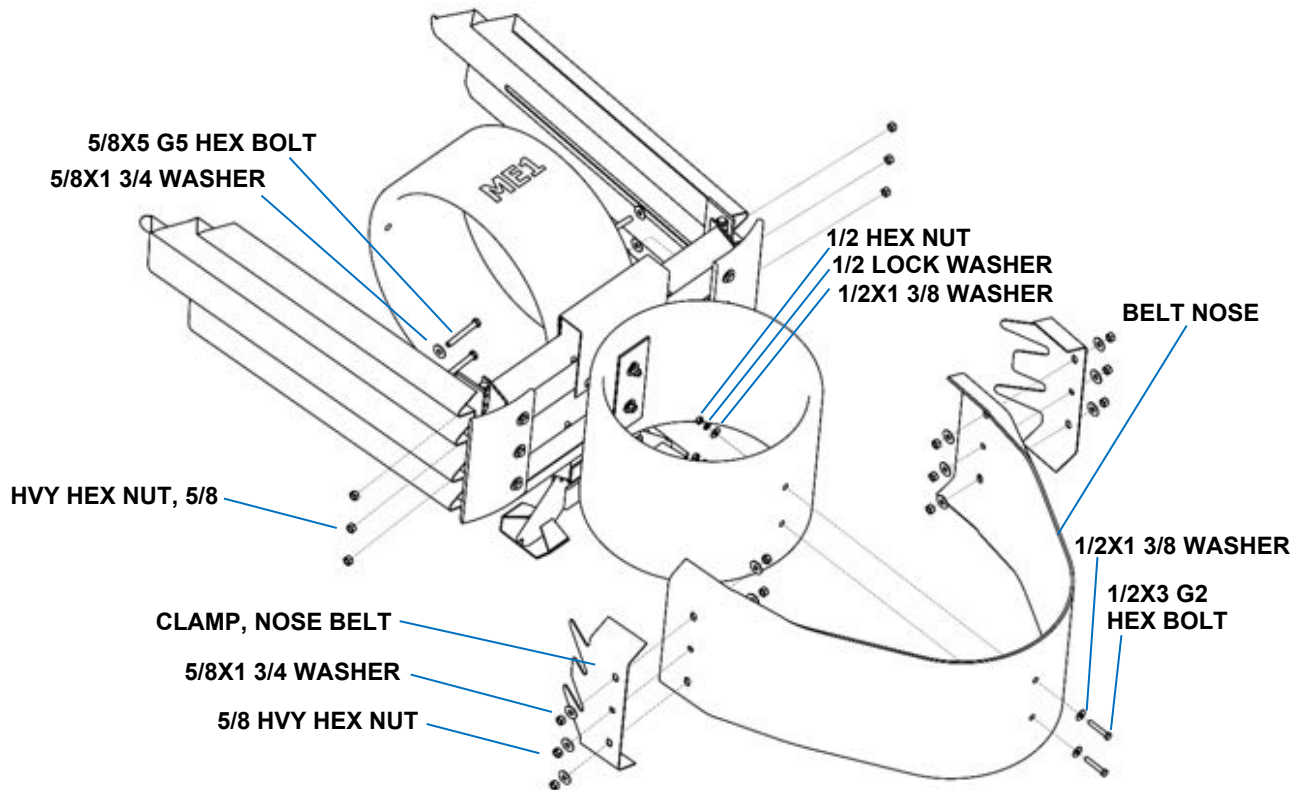

Figure 38
Attach Nose Belt to Fender Panels

16) Attach Hit Indicator to Diaphragm No. 1

The Hit Indicator should be the last component attached to the system. Fasten the Hit Indicator to the first Diaphragm as shown in Figure 39. Offset component to right side of Diaphragm.

Step 1. Position Hit Indicator on 1st Diaphragm. Center Hit Indicator between Diaphragm Extension and edge of Diaphragm. Drill one 1/4" hole as needed to set bracket tab in Diaphragm.

Step 2. Attach hit indicator to 1st Diaphragm.

Option 1. Match drill two 9/16" holes as needed in Diaphragm. Use 1/2" hex bolts, 1/2" lock washers, and 1/2" hex nuts to attach bracket (p. 53).

Option 2. Use 1/4" self-drilling + tap screws along with flat washer to attach bracket.

Step 3. Rotate Hit indicator to horizontal position and bend trigger clip around top of 2nd Diaphragm (Figure 40).

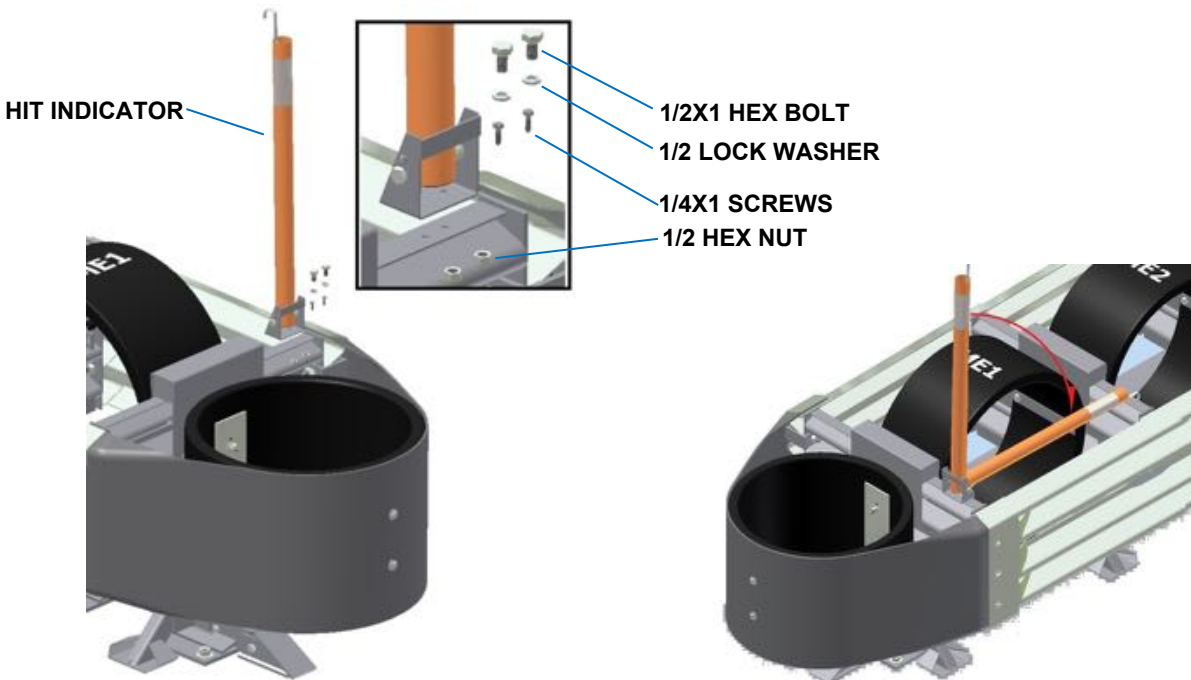

Figure 39
Attach Hit Indicator

Figure 40
Rotate Hit Indicator/Bend Trigger Clip

17) Checking The System Assembly

At this point tighten all Mushroom Washer Assembly nuts until they bottom out on the threads of screws and recheck to ensure that all fasteners are properly tightened throughout the system (anchor bolts, etc.). Check all Fender Panels. If they do not fit tightly against the underlying panel, system realignment may be necessary (Figure 41).



Bolt Torque Specifications	
Warning:	
Anchor Studs	Torqued to Adhesive Manufacturer's Specification Shall Not Extend Above Concrete Pad More than 1 1/2" (p. 24)
All Other Bolts	Tightened
Fender Panel	Maximum gap allowed: WIDE Systems – 1.0" [25 mm]

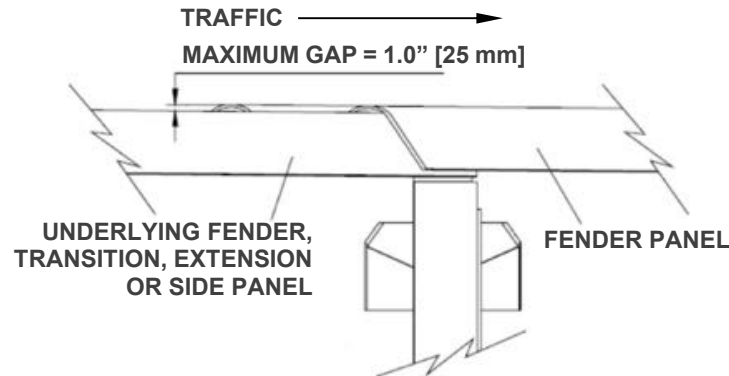

Figure 41
Fender Panel Gap

18) Inspect System

Inspect the system in accordance with Maintenance Flow Chart (p. 40).

QuadGuard® Elite M10 Wide Final Inspection Checklist

Site Location: _____

Date: _____

Inspector: _____

Refer to the QuadGuard® Elite M10 Wide manual and/or drawing package.

- € Proper Transition Panel is used for barrier type (p. 11)
- € If no transition is used, side panels are used with backup (p. 11)
- € Minimum clearance of 25" behind rear Fender Panels for movement (p. 14)
- € Anchor nuts are torqued to adhesive manufacturer's specification (p. 16)
- € Cylinder types are properly placed (p. 19)
- € Every borehole and slot in Backup and Monorail is utilized (pp. 23, 24)
- € Anchor stud(s) height is 1 1/2" [38 mm] or less above the pad (p. 24)
- € Monorail guides are attached to the Diaphragms (p. 26)
- € Cylinder Segments are fastened on each side of the 1st Diaphragm (p. 27)
- € Monorail End Cap Assembly in place (p. 27)
- € Mushroom Washer Assembly nuts must be tightened to the bolt shank. (p. 32)
- € Mushroom Washers tabs lay flat within Fender Panel slots (pp. 33, 39)
- € Belt Nose Assembly and is 32" above grade (p. 33)
- € Fender Panel gap is 1.0" [25 mm] or less for Wide systems (p. 43)
- € Bolts and nuts are properly tightened throughout the system (p. 43)
- € System is clear of debris

Maintenance and Repair



Important: Inspections are recommended, as needed, based upon volume of traffic and impact history. Visual Drive-By Inspections are recommended at least once a month. Walk-Up Inspections are recommended at least once a year.

Visual Drive-By Inspection

- 1) Encountering a system with the Hit Indicator in the vertical position mandates inspection of the system. A walk-up inspection will be necessary.
- 2) Inspect the system in accordance with the QuadGuard® Elite M10 Wide Maintenance Flow Chart (p. 40).



Caution: It is important to inspect a system after it has been impacted even if it appears to be self-restored and fully maintained. In particular, check the Fender Panels/Diaphragm attachment bolts to be sure none have failed.

- 3) Be sure the Nose assembly is in place and in good condition.
- 4) Note the location and condition of the QuadGuard® Elite M10 Wide and the date of visual drive-by inspection.

Walk-Up Inspection



Warning: A system that has been impacted can store energy in collapsed Cylinders and may spring back unexpectedly causing possible serious injury. Use caution when inspecting, disassembling or restoring systems that are collapsed or compressed by any amount.

Maintenance Checklist

- 1) Clear and dispose of any debris on the site. Check along length of Monorail and remove any debris.
- 2) All bolts are tight and rust free.
- 3) Monorail Anchor Nuts are securely anchored.
- 4) Diaphragm Legs are straight.
- 5) All Mushroom Washer Assemblies are properly aligned and positioned (p. 43).
- 6) Fender Panels and Transition Panels should nest tightly against the system. For wrong way traffic, the maximum gap allowed is 1.0" [25 mm].
- 7) All Cylinders are in good condition and are properly positioned within each Bay.
- 8) Always inspect system if the Hit Indicator is in the UP position even if it appears normal.

Note: The energy absorbing HDPE Cylinders lose their ability to absorb energy with increasing number of system impacts. After multiple full capacity design impacts, the system will no longer be able to meet the requirements as specified in MASH. To ensure that Cylinder replacement is accomplished before this condition occurs, it is essential that this part of the inspection be conducted every time the Hit Indicator indicates the system has been impacted.

The rear-most Cylinder must measure at least 26" [660 mm] for proper impact performance (Figure 42). If distance is less than 26" [660 mm], replace all ME1 and ME2 Cylinders. If distance is greater than 26" [660 mm], inspect all Cylinders for major cracks, tears or cuts. Replace any damaged Cylinders. Please call Customer Service if you have any questions (p. 3).

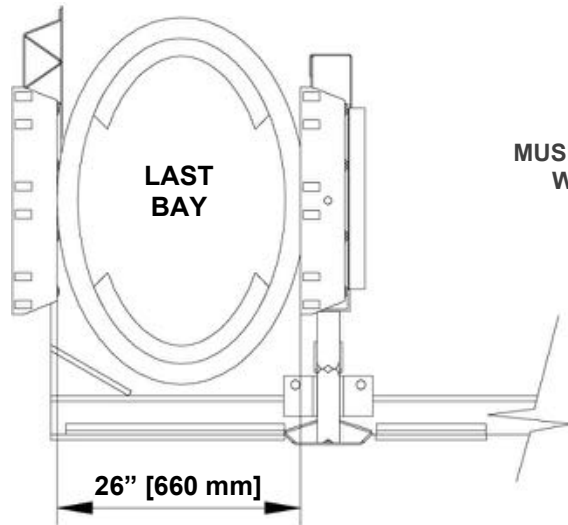

Figure 42
Distance Across
Minor Axis of ME2 Cylinder

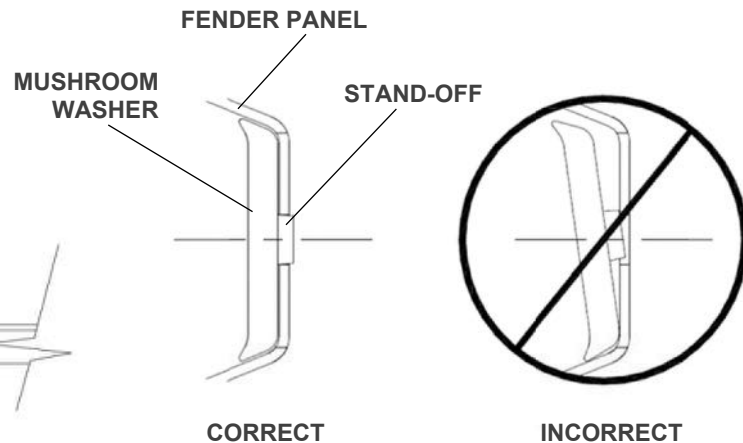

Figure 43
Mushroom Washer Orientation

- 9) Ensure the system is deployed to its full length.



Caution: Systems that are not restored to their full length may not perform to impact performance standards of MASH.

- 10) Make all necessary repairs as described above and see the following page for Post-Impact Instructions.
- 11) Reset Hit Indicator if necessary.
- 12) Note the location and condition of the QuadGuard® Elite M10 Wide, and any work done, in your **Impact Attenuator Inspection Logbook** under the date of this inspection. If further repair is required, note repair request date in logbook. Walk-up inspections are recommended as needed based upon volume of traffic and impact history. Refer to Post-Impact Instructions for more information (p. 41).

Maintenance Flow Chart

Refer to the appropriate sections of this manual for specific procedures.

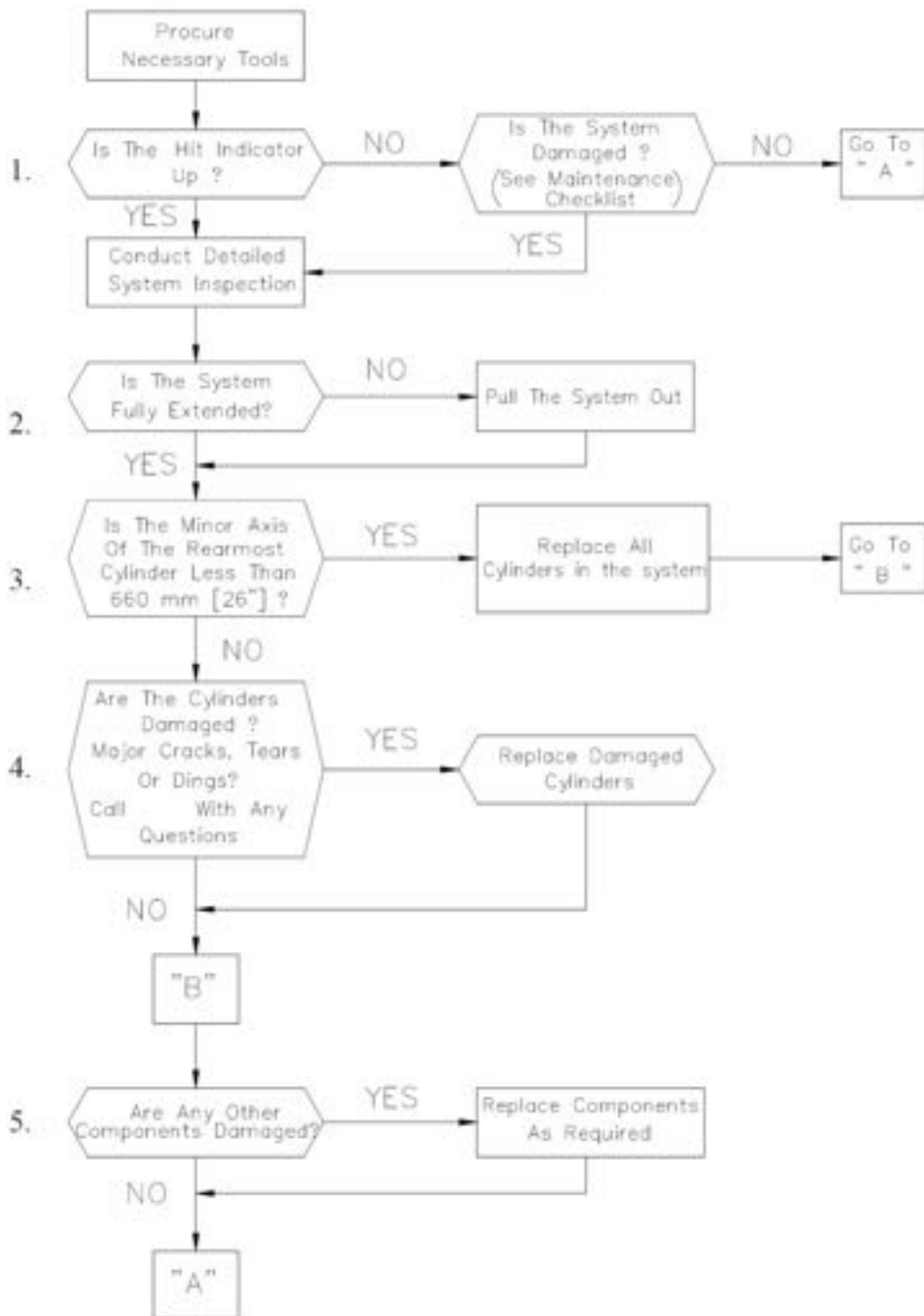

Post-Impact Instructions

- 1) Deploy the appropriate traffic-control devices to protect your crew.



Warning: An impacted system can store energy in collapsed Cylinders and **may spring back unexpectedly** causing serious injury. Use caution during post-impact inspections for repair or refurbishment.



Warning: It is the responsibility of the worker to keep hands and other body parts clear of system interaction. Be aware of tools (pry bar, etc.) that could move unexpectedly if a bind is suddenly released.

- 2) Position a minimum 1 ton pickup truck on the system just in front of the Nose Assembly. Place the truck bumper against the system. The truck bumper height, approximately 24" [610 mm], should rest against the middle center of the Nose Assembly.



Warning: Once the bumper is over the system's Monorail, the vehicle may be subject to pushing force due to unexpected restoration. The driver should be wearing a seat belt and have the vehicle in the lowest possible gear when approaching the system. In the event that the system unexpectedly deploys before Step 2 is complete, the driver should apply the brakes immediately to bring the vehicle to a controlled stop. The vehicle must be in neutral while still applying the brakes and then gradually release the brakes to allow the system to restore against the truck bumper in a safe and controlled way.

- 3) Once in place, carefully move the truck so the bumper displaces the Nose Cylinder 6". In the absence of the Nose assembly, place protective material between the bumper and the first Diaphragm leaving a 1.00" gap between the protective material and the truck bumper. It is the responsibility of the driver to remain in the vehicle to apply the brake during initial system displacement.



Caution: Use a pry bar with a 1 ton truck to release additional mechanical binds in a safe and controlled manner.

- 4) Wrap a chain, 3/8"X20' Grade 40 minimum, around the first Diaphragm (Figure 44). Attach both ends of chain to truck bumper anchor points.



Important: Wrap chain around the first Diaphragm so the pull force is aligned with the long slots in the Fender Panels to ensure a smoother extension.



Warning: Stand clear in case chain breaks or becomes disconnected.



Important: Have someone watch during repositioning to ensure undetected damage does not cause the Diaphragms to bind or pull out improperly. Wait ten minutes after full extension for Cylinders to regain their former shape.

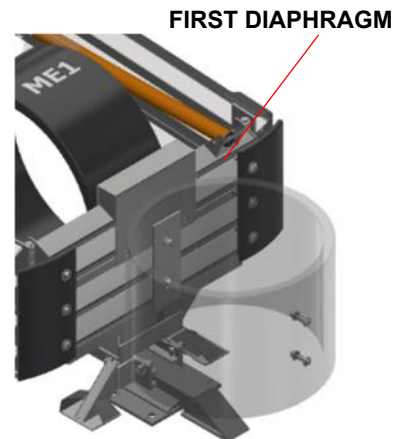

Figure 44
Attach Chain to First Diaphragm

- 5) Ensure the Mushroom Washer Assemblies holding the Fender Panels together are still intact and the system has not been deformed to prevent it from pulling back fully to its original position.



Caution: Use eye protection and gloves when repairing any Mushroom Washer Die Spring Assembly. Do not place fingers underneath an assembled Mushroom Washer. Parts may suddenly shift and fingers may be pinched. If the Die Spring is still under compression, then secure it with a clamp to ensure safe action and release when the nut is removed.

- 6) The system should now be safe to approach for debris removal and further mechanical binding inspection. Binding is typically located at the Monorail Guides near the front Diaphragms or Fender Panels.
- 7) Verify all Anchor Bolts are firmly anchored to the roadway surface. Replace any loose, broken, or pulled out Anchors. Proper performance of the system depends on the Monorail Anchors being properly deployed.
- 8) All Diaphragm Support Legs must be properly attached to the Monorail.
- 9) Inspect the system in accordance with the QuadGuard® Elite M10 Wide Maintenance Flow chart (p. 40). The Cylinders are potentially reusable after typical design speed impacts. See the Limitations and Warnings section on page 5.
- 10) Diaphragms that are bowed or have bent legs must be replaced.
- 11) Each Fender Panel must be properly attached with a Mushroom Washer Assembly. Check all Fender Panel to Diaphragm bolt connections. All damaged bolts, Fender Panels and Transition Panels must be replaced.
- 12) The maximum gap allowed for overlapping Fender Panels on the side of the system with traffic approaching from the rear (including Fender Panels overlapping components behind the system) is 1.0" [25 mm]. Mushroom Washer Assembly nuts must be tightened to the bolt shank. Replace damaged parts if a gap between any Fender Panel exceeds 1.0" [25 mm] (p. 43).
- 13) Replace all damaged Cylinders. If a Cylinder's condition is questionable, a photo of the Cylinder may be forwarded to Valtir for evaluation (p. 3).
- 14) Tighten and torque all fasteners on the system (p. 36).
- 15) Clear site debris.
- 16) The QuadGuard® Elite M10 Wide is ready for use.



Important: Because every impact is different, Valtir makes no recommendation whether use or reuse of any part of the system is appropriate or acceptable following an impact. It is the sole responsibility of the project engineer and/or the local highway authority and its engineers to make that determination. It is critical that you inspect this product after assembly is complete to make certain that the instructions provided in this manual have been strictly followed.



CAUTION:

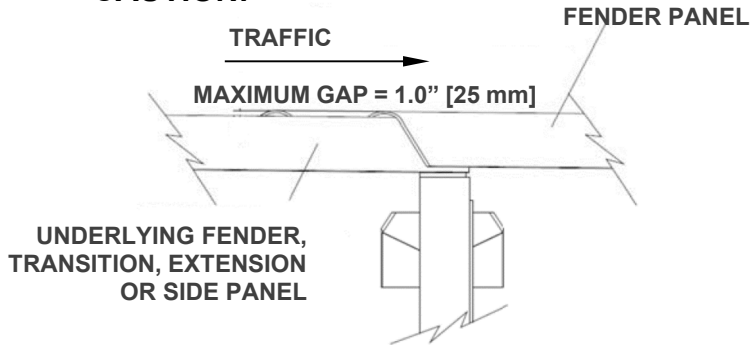

**Figure 45
Fender Panel Gap**



Torque Specifications	
Warning:	
Mushroom Bolt Assemblies	Tighten nut to bolt shank
Anchor Studs	Torqued to adhesive manufacturer's specification. Shall Not Extend Above Concrete Pad More than 1 1/2" (p. 24)
All Other Bolts	Tightened
Fender Panel	Maximum Gap Allowed
WIDE System	1.00" [25 mm]

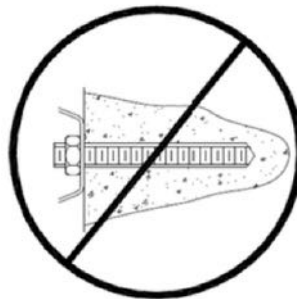
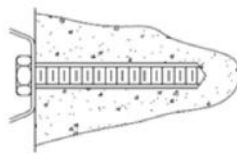

**Figure 46
Horizontal Anchor**

Parts Ordering Procedure and Drawings

Make a list of all damaged parts using part descriptions illustrated on drawings in the back. Answer the following questions in the spaces provided. This information is necessary to receive the proper parts.

QuadGuard® Elite M10 Wide Ordering Information Chart		
Description:	Choices	Fill in this section
Transition Panel Type Right side, left side, or no Transition (p. 11)	W-Beam Thrie Beam Guardrail Safety Shape Barrier Single Slope Barrier Verticle Concrete	
Width of Backup	4" [100 mm] Offset Panel	

Parts List(s) & Quantities

PN	Description	Count
118710	Adhesive, HY200, 330, Hilti	17
618847	Backup, TS, 64, QGE, G, W/Decals	1
605108	Belt, Nose, 96, QGE, 90, 7 Bay, Y	1
113467	Bolt, Hex, 1/2x1, G5, G	2
113476	Bolt, Hex, 1/2x3, G2, G	2
113555	Bolt, Hex, 3/4x2, G8, G	32
113573	Bolt, Hex, 3/4x5, G5, G	2
113612	Bolt, Hex, 3/8x3 1/2, All Thread, G5, G	16
113660	Bolt, Hex, 5/8x3 1/2, G5, G	1
113666	Bolt, Hex, 5/8x4, G5, G	54
113667	Bolt, Hex, 5/8x5, G5, G, All Thread	12
004489	Bolt, Hex, 5/8x9, A325	15
003400	Bolt, Rail, 5/8x2, G	6
606330	Clamp, Nose Belt, QG, G	2
618702	Cylinder Assy, ME3, MASH, QGE	4
627504	Cylinder Seg, 18x9 1/2x0.8	2
618538	Cylinder, ME1, MASH, QGE	1
618649	Cylinder, ME2, MASH, QGE	3
606689	Cylinder, Nose, HDPE, 28x20	1
627503	Diaphragm, QG, 0993, QGE	1
619120	Diaphragm, QG, 1073, QGE	1
619121	Diaphragm, QG, 1153, QGE	1
619122	Diaphragm, QG, 1233, QGE	1
619124	Diaphragm, QG, 1313, QGE	1

PN	Description	Count
619125	Diaphragm,QG,1393,QGE	1
619126	Diaphragm,QG,1473,QGE	1
619128	Diaphragm,QG,1553,QGE	1
608136	Endcap,Monorail,QG	1
618526	Extension,Diaphragm,Angle	8
618536	Extension,Backup,M10,QGE	1
618652	Flt St 3/16x2x13,W/Holes	16
610172	Hinge Plate,Fender Panel,QG	18
610238	Hit Indicator,LMC/Elite	1
611368	Monorail Guide,QG,G	16
611370	Monorail,1 Bay,QG	1
611379	Monorail,3 Bay,QG	2
003704	Nut,Heavy Hex,3/4,A563DH	116
003354	Nut,Heavy Hex,5/8,A563A	81
115939	Nut,Hex,1/2,G	4
115960	Nut,Hex,3/8,G	16
003340	Nut,Hex,5/8,G,Rail	52
611832	Panel,Fender,QG	16
611900	Panel,Side,QG,Wide,G	2
612253	Plate,Nose Cylinder	1
116879	Screw,FL,5/8x8 1/2,G8,G,Socket	16
116891	Screw,HWH,1/4x1,Self Drill/Tapping,G	2
117458	Spring,Die,1 1/2ODx3/4x6,G	16
117542	Stud,3/4x7,G5,G	68
615756	Tel St,1 3/4x1 3/4x12 GAx10,H4S,G	4
615765	Tel St,2x2x12 GAx10,H4S,G	4
118009	Washer,Flat,1/2x1 3/8,G	4
118013	Washer,Flat,1/4x1,G	2
003300	Washer,Flat,5/8x1 3/4,G	33
118027	Washer,Flat,Hvy,3/4x2,G	68
118082	Washer,Lock,1/2,G	4
118089	Washer,Lock,3/4,G	32
118092	Washer,Lock,3/8,G	16
118100	Washer,Lock,5/8,G	57
617045	Washer,Mushroom,Forged,QG,G	16



Warning: Use only Valtir parts that are specified herein for assembling, maintaining, or repairing the QuadGuard® Elite M10 Wide. **Do not utilize or otherwise comingle parts from other Valtir systems.** Such configurations have not been tested, nor have they been deemed eligible for use. Assembly, maintenance, or repairs using unspecified parts or accessories is strictly prohibited.

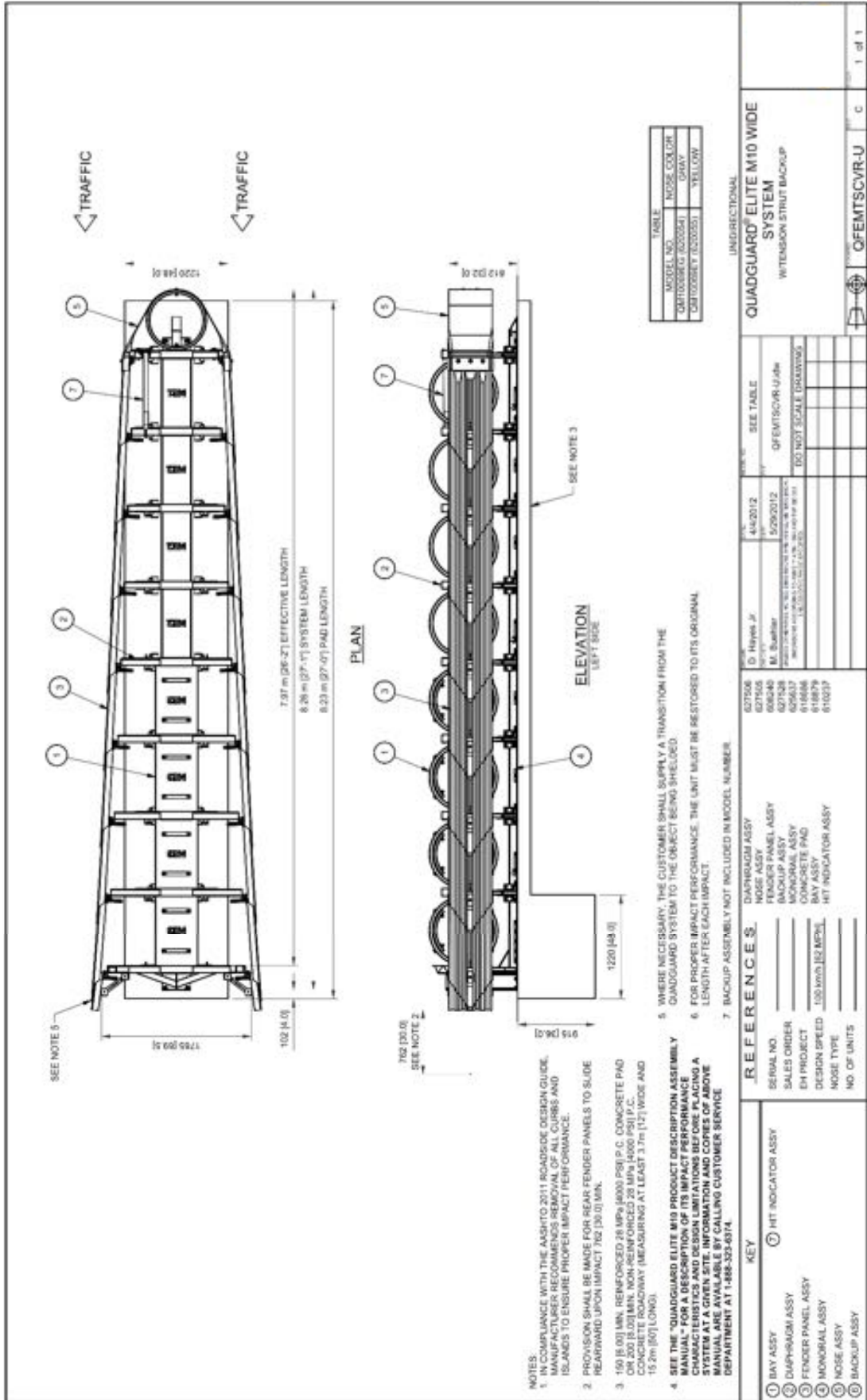

QuadGuard® Elite M10 Wide QFEMTSCVR-U

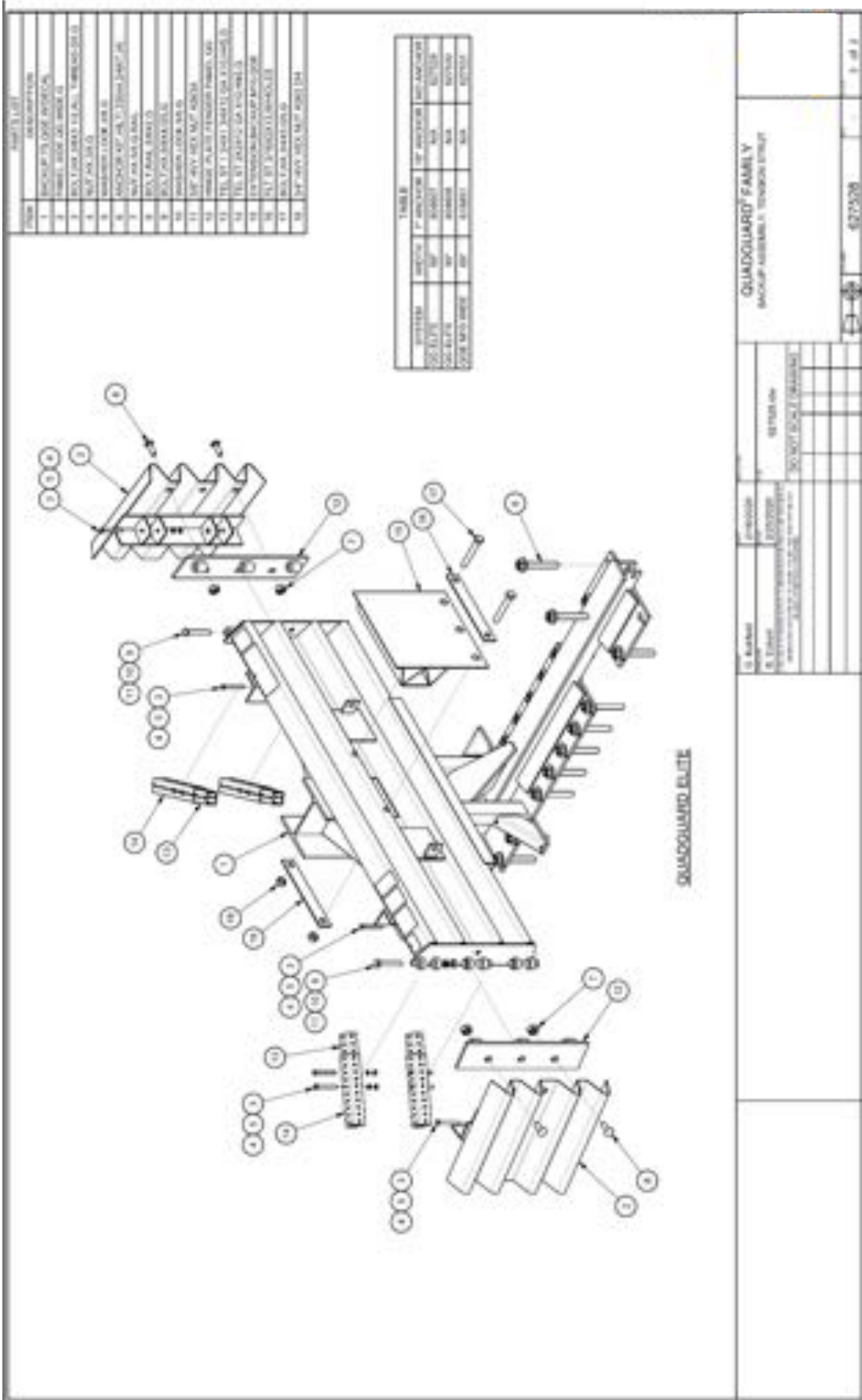

Backup Assembly, Tension Strut 627528

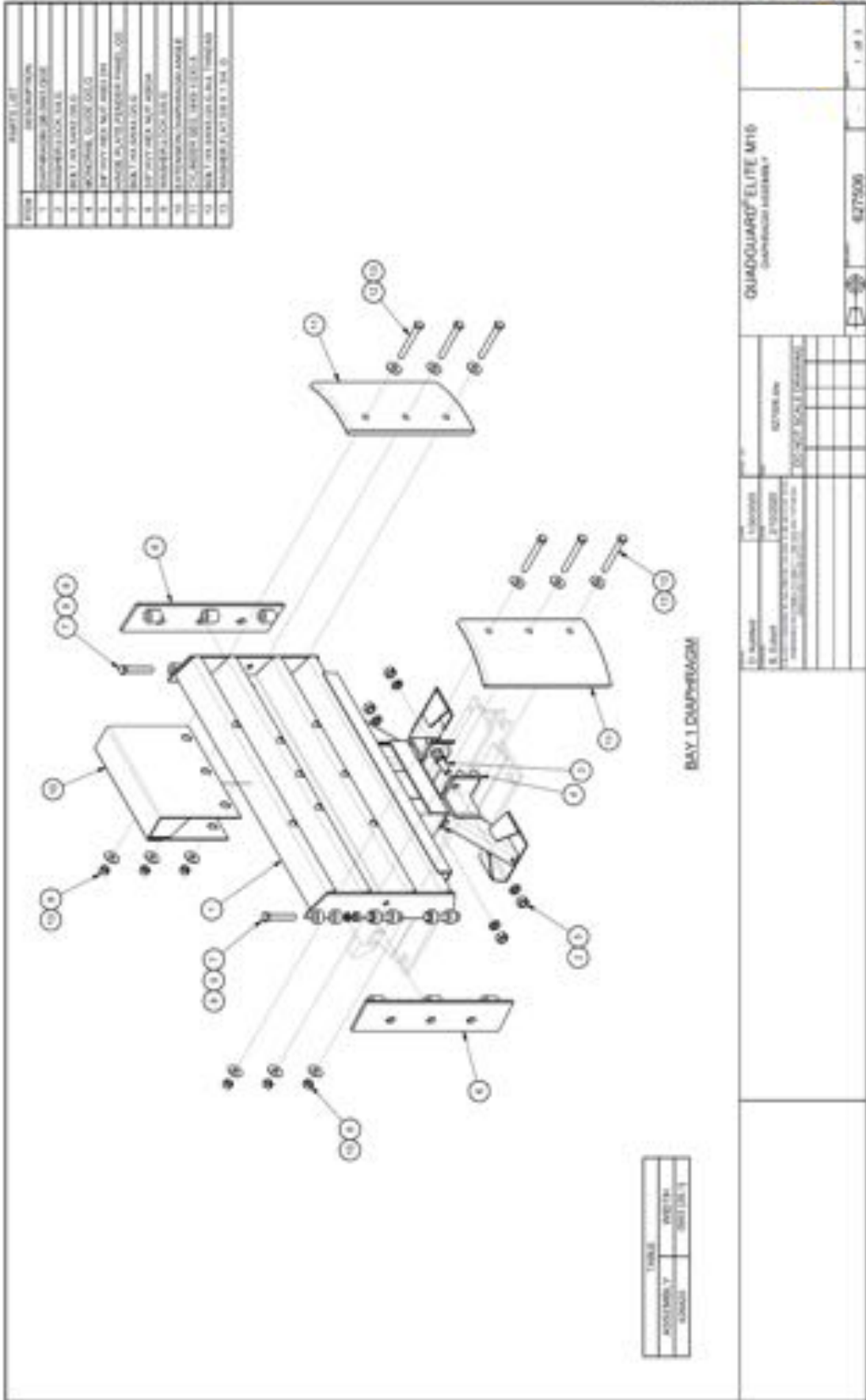

ITEM	DESCRIPTION
1	DIAPHRAGM
2	SUPPORT PLATE
3	SCREW
4	SCREW
5	SCREW
6	SCREW
7	SCREW
8	SCREW
9	SCREW
10	SCREW
11	SCREW
12	SCREW
13	SCREW
14	SCREW
15	SCREW
16	SCREW
17	SCREW

Bay 1 Diaphragm Assembly 627506

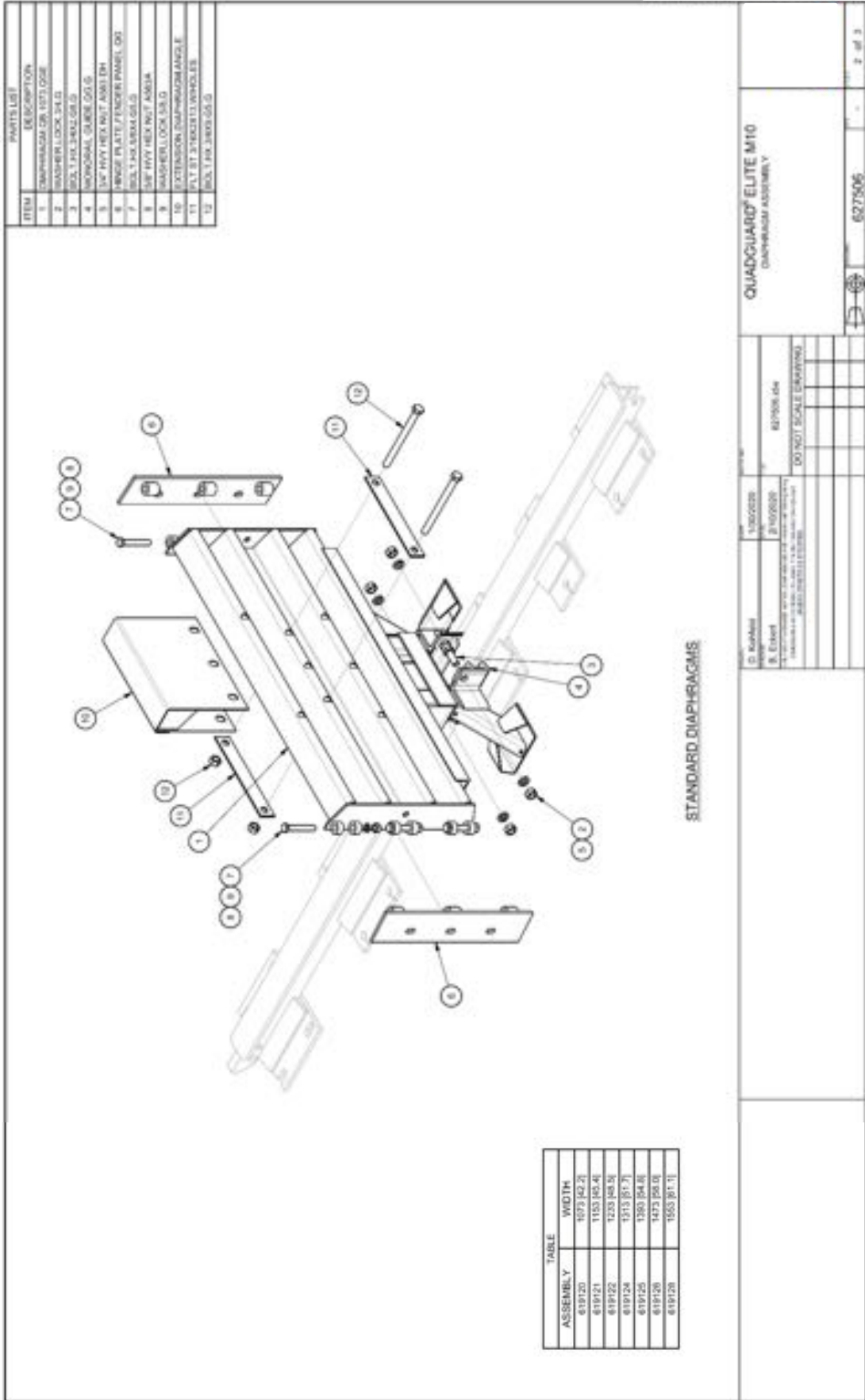

Standard Diaphragm Assembly 627506

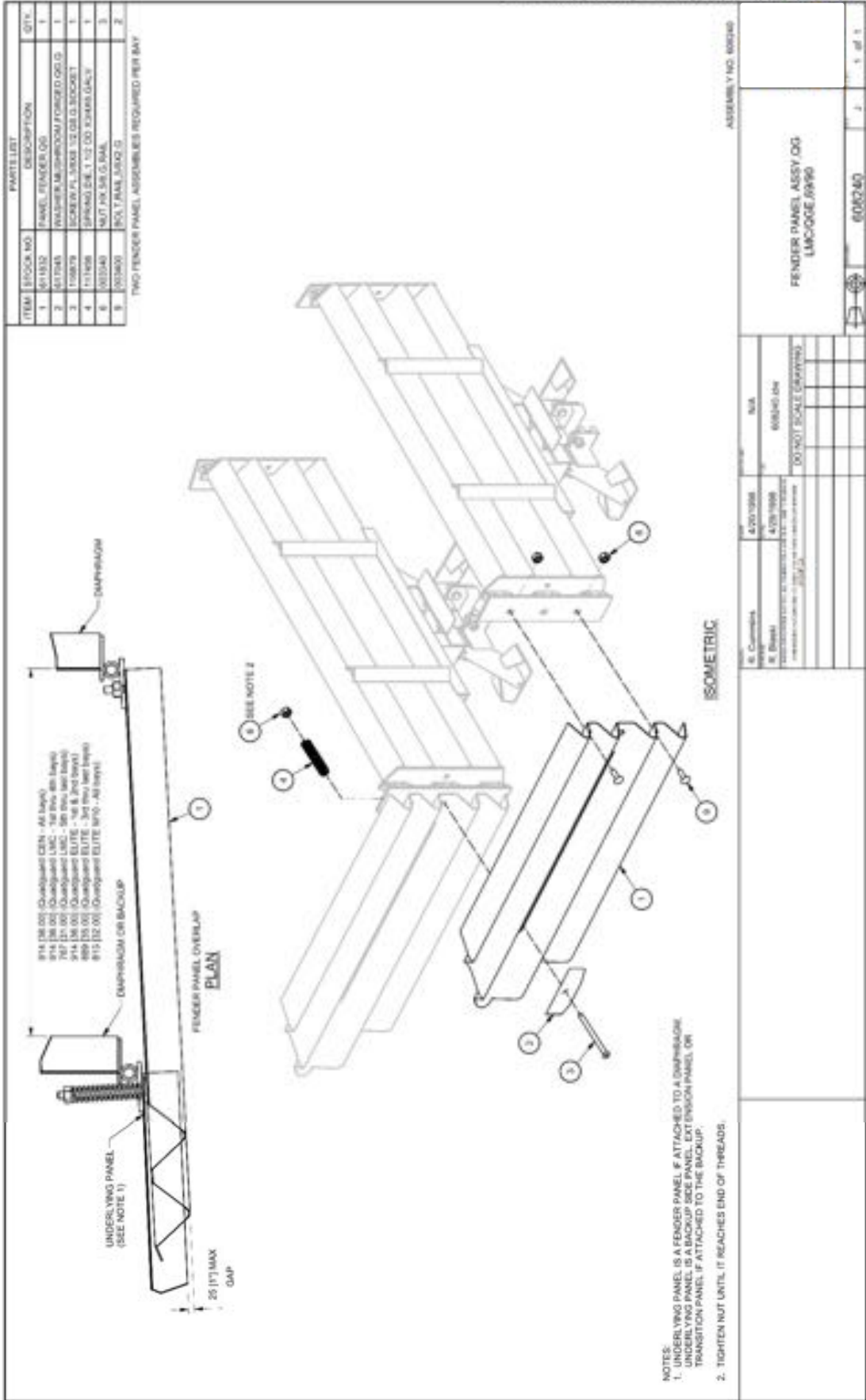

Fender Panel Assembly 608240

ITEM	PARTS LIST	DESCRIPTION
1	BOLT NOSE GAGE	
2	CYLINDER NOSE HOPE BRACK	
3	NUT M6 X 12.0	
4	WASHER FLAT 42X31 3H.6	
5	SCREW PAN.50X5.0X1.0 ALL THREADED	
6	WASHER FLAT 48 X 11 3H.10	
7	BOLT PHX 12X3.02.0	
8	BOLT PHX 12X3.02.0	
9	CLAMP NOSE BELT 50.0	
10	PLATE NOSE CYLINDER	
11	SPACER HEX BOLT ASST	
12	NUT WTY HEX NUT ASST	
13	WASHER LOCK 15.0	
14	WASHER LOCK 15.0	

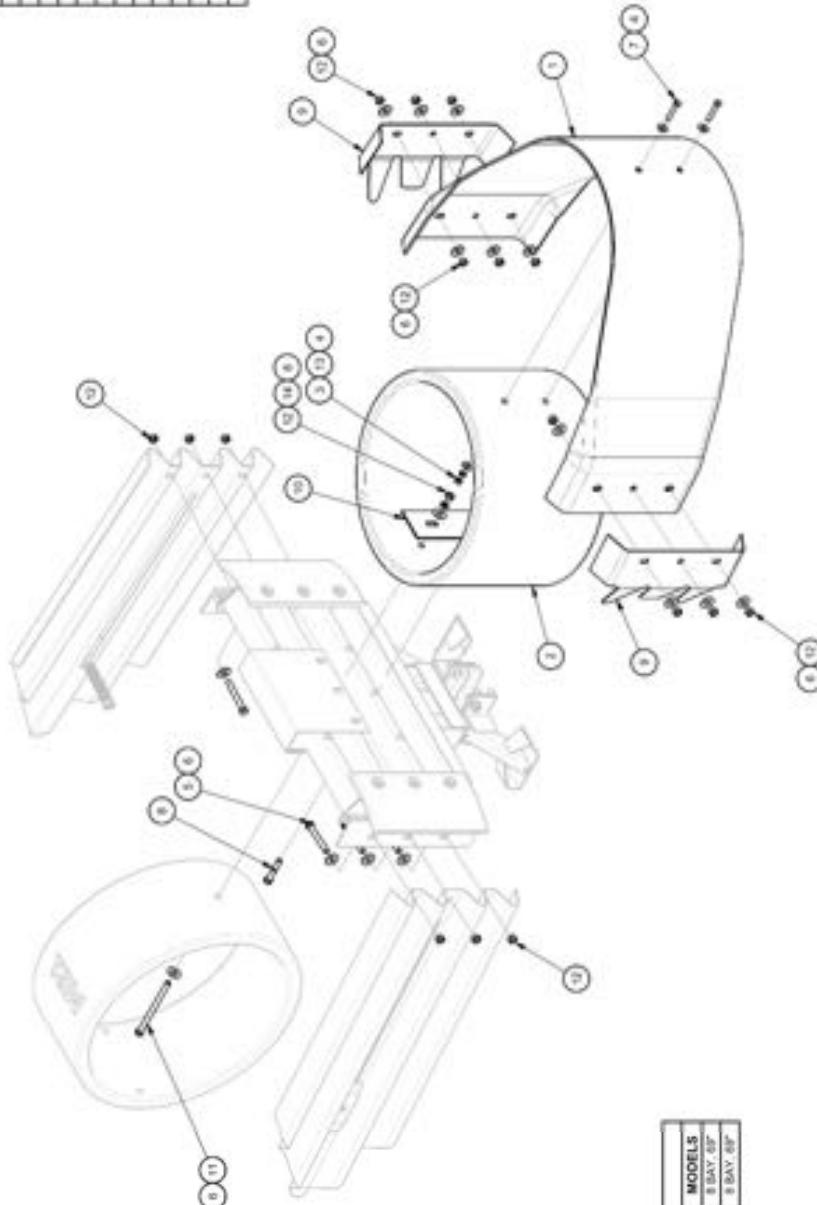

ASSEMBLY	COLOR	MODELS
620028	GRAY	8 BAY, 6P
618870	YELLOW	8 BAY, 8P

QUADGUARD [®] ELITE M10 NOSE ASSY M10.06		627505	1 of 1
REV. NO.	REV. DATE	REV. BY	REV. DATE
1	1/10/2020	B. Eshel	627505-000
(DO NOT SCALE DIMENSIONS) DIMENSIONS ARE IN MILLIMETERS UNLESS OTHERWISE SPECIFIED			

Nose Assembly 627505

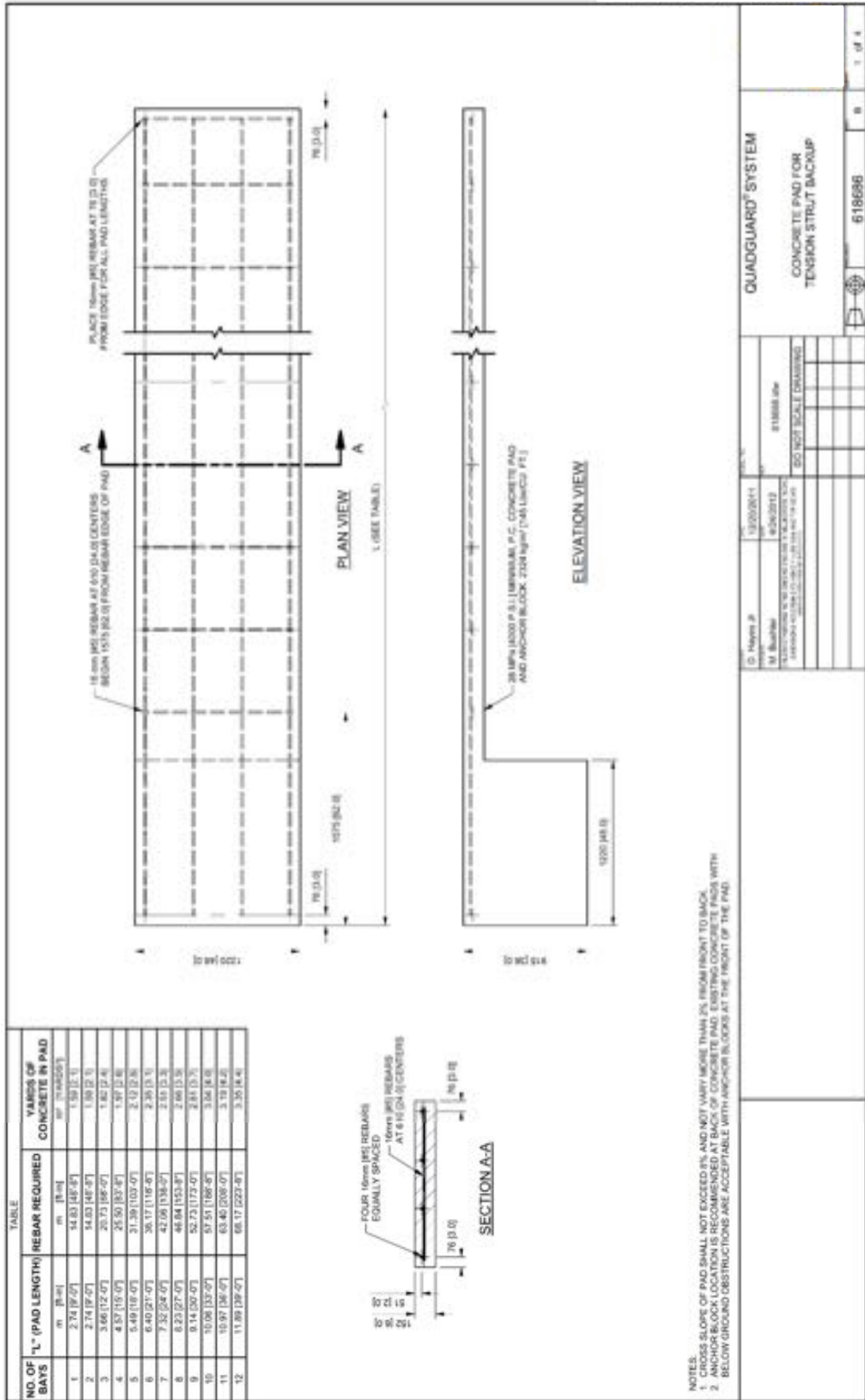

TS Concrete Pad 618686

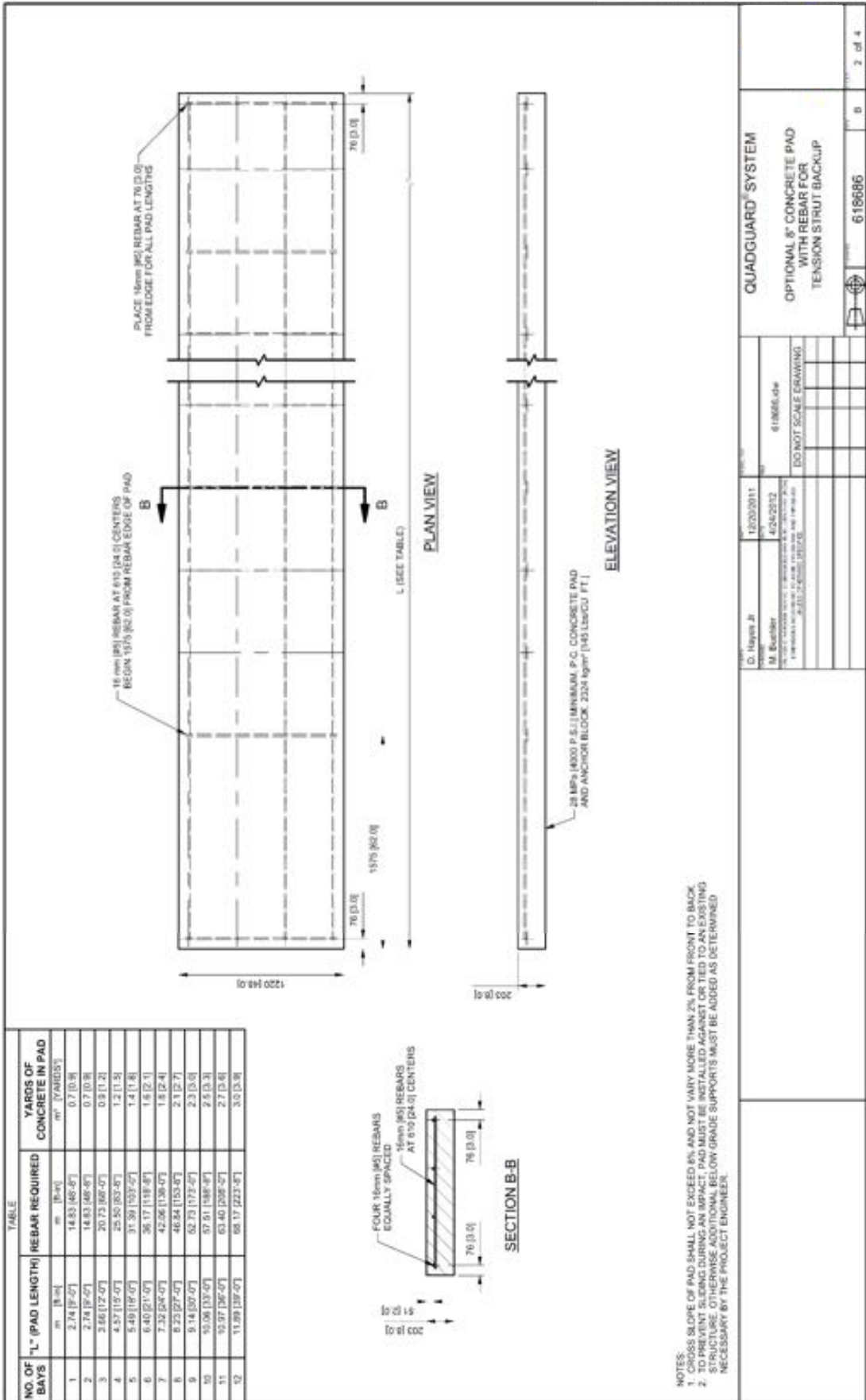

TS Concrete Pad 8" w/Rebar 618686

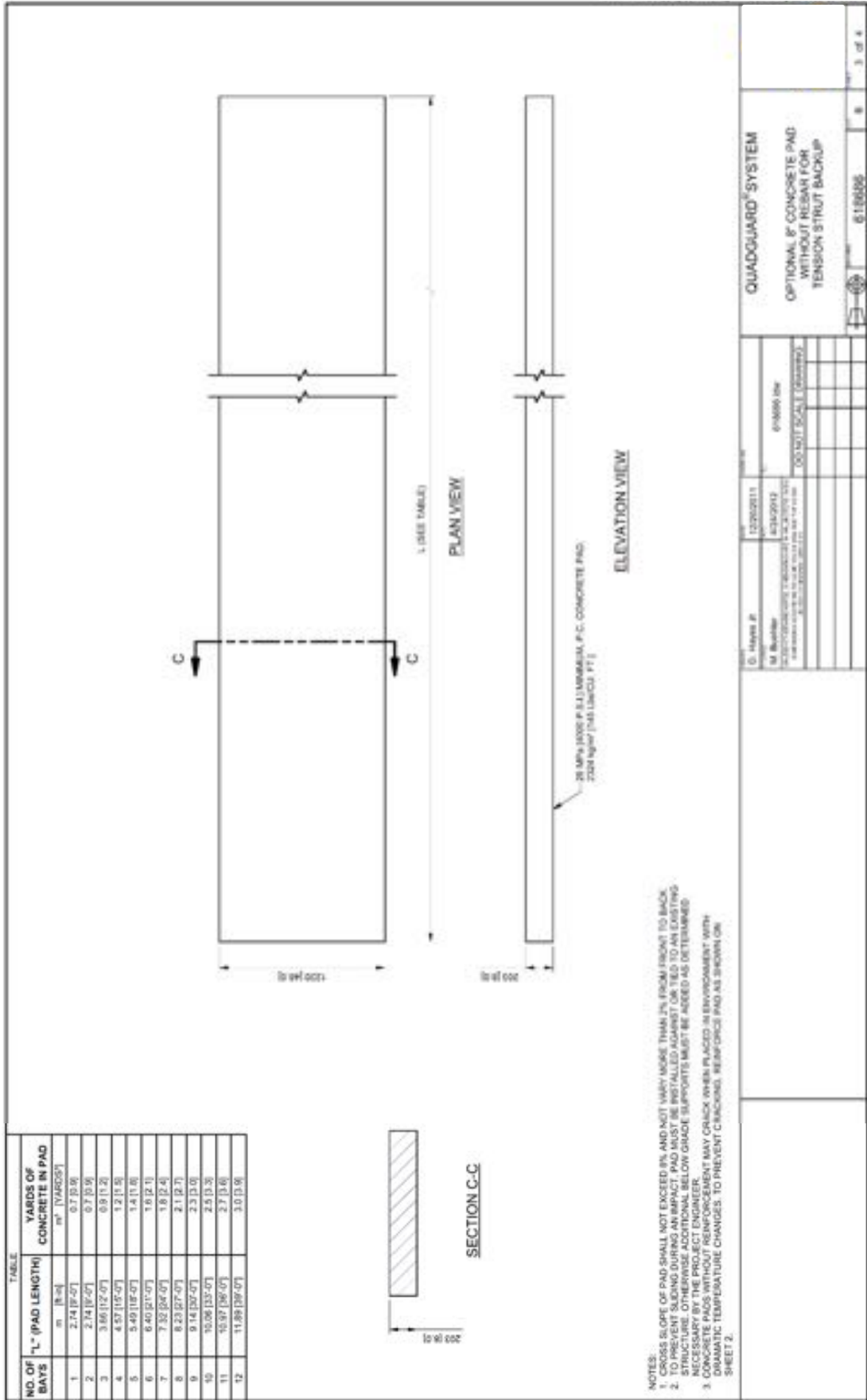

TS Concrete Pad 8" wo/Rebar 618686

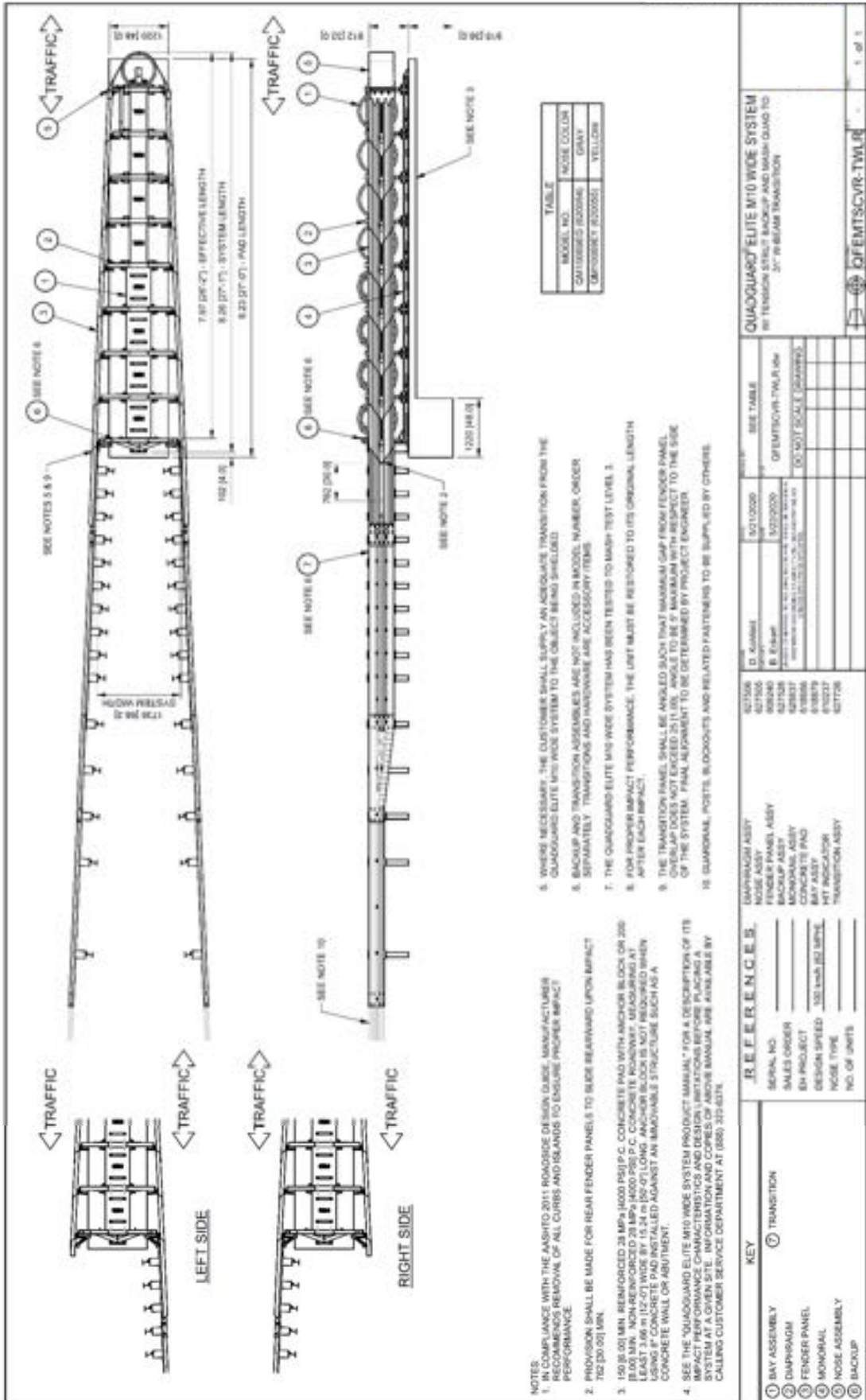

31' W-Beam Transition QFEMTSCVR-TWLR

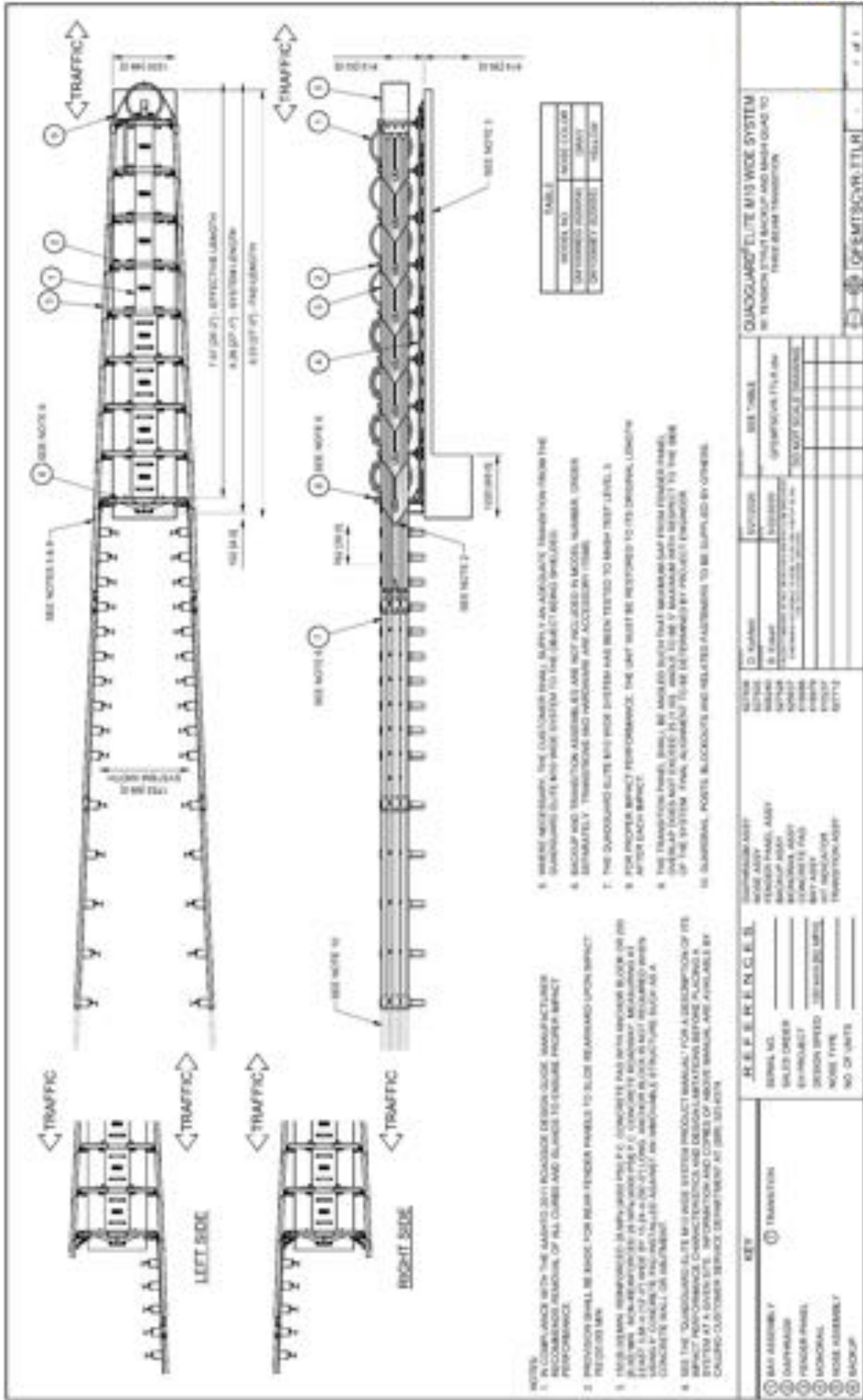

Thrie-Beam Transition QFEMTSCVR-TTLR

QUADROGLITE M13 WIDE SYSTEM
 RE TENSION STAY BACKUP AND MARK OADS TO
 THREE BEAM TRANSITION

OFEMTSCVR-TTLR

1 of 1

TABLE NO.	NOTE COLUMN
1	1
2	2
3	3
4	4
5	5
6	6
7	7
8	8
9	9
10	10
11	11
12	12
13	13
14	14
15	15
16	16
17	17
18	18
19	19
20	20
21	21
22	22
23	23
24	24
25	25
26	26
27	27
28	28
29	29
30	30
31	31
32	32
33	33
34	34
35	35
36	36
37	37
38	38
39	39
40	40
41	41
42	42
43	43
44	44
45	45
46	46
47	47
48	48
49	49
50	50
51	51
52	52
53	53
54	54
55	55
56	56
57	57
58	58
59	59
60	60
61	61
62	62
63	63
64	64
65	65
66	66
67	67
68	68
69	69
70	70
71	71
72	72
73	73
74	74
75	75
76	76
77	77
78	78
79	79
80	80
81	81
82	82
83	83
84	84
85	85
86	86
87	87
88	88
89	89
90	90
91	91
92	92
93	93
94	94
95	95
96	96
97	97
98	98
99	99
100	100

- 1. IN COMPLIANCE WITH THE AASHTO 3011 ROADSIDE DESIGN GUIDE, MANUFACTURER RECOMMEND REMOVAL OF ALL CURBS AND SLABS TO ENSURE PROPER IMPACT PERFORMANCE.
- 2. PROVISION SHALL BE MADE FOR REAR TENSION PILES TO SLIDE REARWARD UPON IMPACT.
- 3. FULL SYSTEM REBARWORK IS TO BE CAST IN PLACE WITH REBAR WORK FOR THE PILES AND ACCESSORIES IN PLACE AND THE PILES AND ACCESSORIES TO BE CAST IN PLACE WITH REBARWORK IN PLACE. THE QUADROGLITE M13 WIDE SYSTEM SHALL BE CAST IN PLACE WITH REBARWORK IN PLACE.
- 4. THE QUADROGLITE M13 WIDE SYSTEM PRODUCT MANUAL FOR A DESCRIPTION OF ITS IMPACT PERFORMANCE CHARACTERISTICS AND DESIGNATIONS BEFORE PLACING THE SYSTEM AT A GIVEN SITE. INFORMATION AND COPIES OF ABOVE MANUAL ARE AVAILABLE BY CALLING CUSTOMER SERVICE 1-877-875-3379 AT 9AM-5PM EST.
- 5. WHERE NECESSARY, THE CUSTOMER SHALL SUPPLY AN AUGMENTED TRANSITION FROM THE QUADROGLITE M13 WIDE SYSTEM TO THE (RIGHT BEAM) SPREADERS.
- 6. BACKUP AND TRANSITION ASSEMBLIES ARE NOT INCLUDED IN MODEL NUMBER, ORDER SEPARATELY, TRANSITIONS AND WORKMAN AND ACCESSORY ITEMS.
- 7. THE QUADROGLITE M13 WIDE SYSTEM HAS BEEN TESTED TO MEET TEST LEVEL 3.
- 8. FOR PROPER IMPACT PERFORMANCE, THE DET MUST BE RESTORED TO ITS ORIGINAL LENGTH AFTER EACH IMPACT.
- 9. THE TRANSITION PILES SHALL BE ANCHORED SUCH THAT MINIMUM GAP FROM PILEHEAD (MINIMUM GAPS NOT EXCEEDED) IS 10% UNLESS TO BE V. MAXIMUM WITH REFERENCE TO THE BAR OF THE SYSTEM. PILE ANCHORS TO BE DETERMINED BY PRODUCT ENGINEER.
- 10. SUBMERGED PORTS, BLOCKOUTS AND RELATED ASSEMBLIES TO BE SUPPLIED BY OTHERS.

KEY		J.E.P.E.R.E.L.C.E.S.		SEE TABLE	
①	BAR ASSEMBLY	QUADROGLITE M13 WIDE SYSTEM	TRANSITION	TRANSITION PILES	TRANSITION PILES
②	DEPRESSION	TRANSITION PILES	TRANSITION PILES	TRANSITION PILES	TRANSITION PILES
③	FRONT PANEL	TRANSITION PILES	TRANSITION PILES	TRANSITION PILES	TRANSITION PILES
④	MONITOR	TRANSITION PILES	TRANSITION PILES	TRANSITION PILES	TRANSITION PILES
⑤	NOSE ASSEMBLY	TRANSITION PILES	TRANSITION PILES	TRANSITION PILES	TRANSITION PILES
⑥	BACKUP	TRANSITION PILES	TRANSITION PILES	TRANSITION PILES	TRANSITION PILES

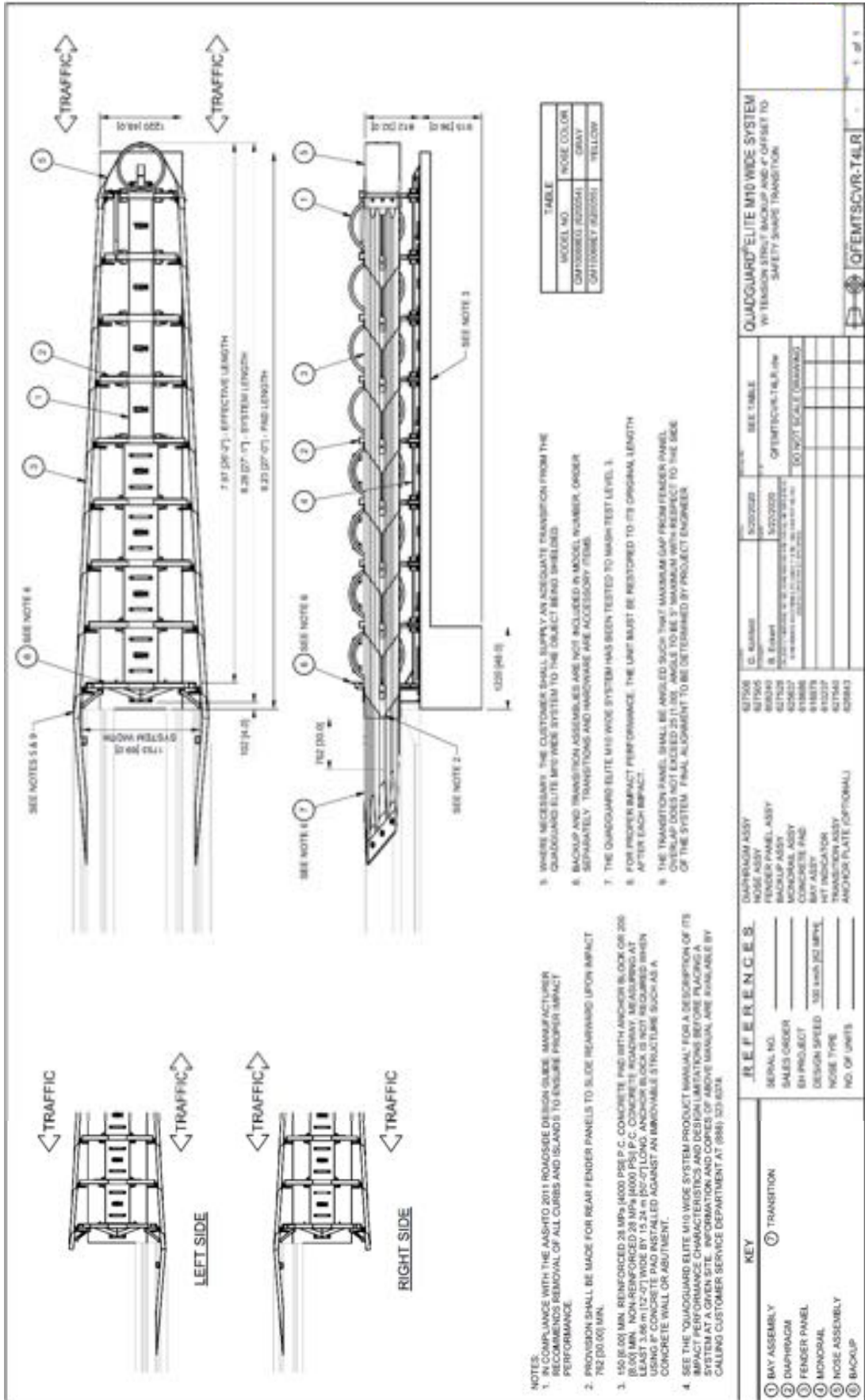

4" Safety Shape Transition QFEMTSCVR-T4LR

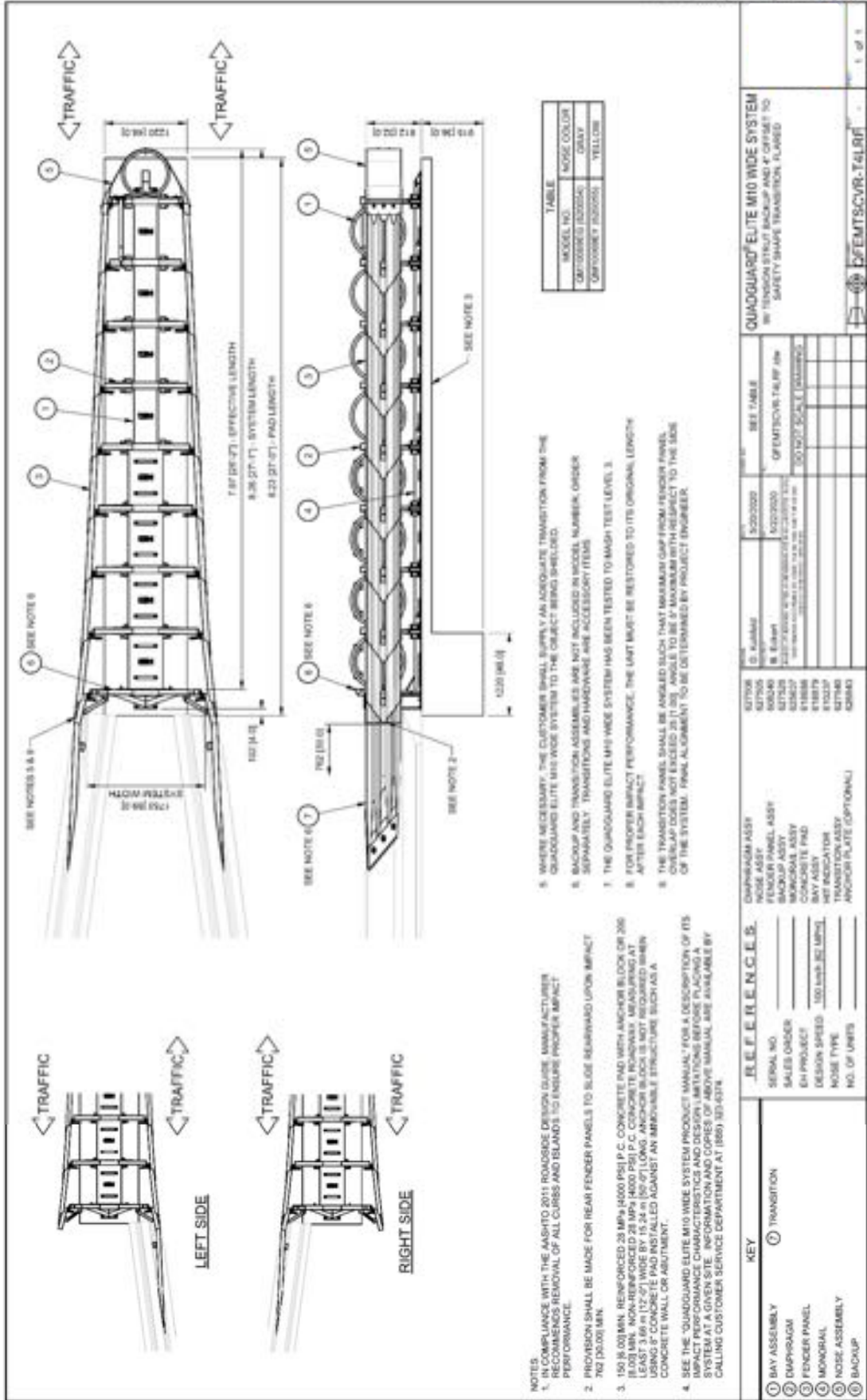

- NOTES**
- IN COMPLIANCE WITH THE AASHTO 2011 ROADSIDE DESIGN GUIDE, MANUFACTURER RECOMMENDS REMOVAL OF ALL CURBS AND ISLANDS TO ENSURE PROPER IMPACT PERFORMANCE.
 - PROVISION SHALL BE MADE FOR REAR FENDER PANELS TO SLIDE REARWARD UPON IMPACT 702 (26.00) MIN.
 - 150 (4.00) MIN. REINFORCED 28 MPa (4000 PSI) P.C. CONCRETE PAD WITH ANCHOR BLOCK OR 206 (6.00) MIN. NON-REINFORCED 28 MPa (4000 PSI) P.C. CONCRETE ROADWAY MEASURING AT 150 (4.00) MIN. FROM THE END OF THE CONCRETE PAD. THE CONCRETE PAD SHALL BE INSTALLED AGAINST AN IMMovable STRUCTURE SUCH AS A CONCRETE WALL OR ABUTMENT.
 - SEE THE "QUAARDGUARD ELITE M10 WIDE SYSTEM PRODUCT MANUAL" FOR A DESCRIPTION OF ITS IMPACT PERFORMANCE CHARACTERISTICS AND DESIGN LIMITATIONS BEFORE PLACING A SYSTEM AT A GIVEN SITE. INFORMATION AND COPIES OF ABOVE MANUAL ARE AVAILABLE BY CALLING CUSTOMER SERVICE DEPARTMENT AT (866) 593-6374.

- WHERE NECESSARY, THE CUSTOMER SHALL SUPPLY AN ADEQUATE TRANSITION FROM THE QUAARDGUARD ELITE M10 WIDE SYSTEM TO THE OBJECT BEING SHIELDED.
- BACKUP AND TRANSITION ASSEMBLIES ARE NOT INCLUDED IN MODEL NUMBER, ORDER SEPARATELY. TRANSITIONS AND HARDWARE ARE ACCESSORY ITEMS.
- THE QUAARDGUARD ELITE M10 WIDE SYSTEM HAS BEEN TESTED TO MASH TEST LEVEL 3.
- FOR PROPER IMPACT PERFORMANCE, THE GART MUST BE RESTORED TO ITS ORIGINAL LENGTH AFTER EACH IMPACT.
- THE TRANSITION PANEL SHALL BE ANGLED SUCH THAT MAXIMUM GART FROM FENDER PANEL OVERLAP DOES NOT EXCEED 25 (1.00) INCHES. ANGLE TO BE 5° MAXIMUM WITH RESPECT TO THE SIDE OF THE SYSTEM. FINAL ALIGNMENT TO BE DETERMINED BY PROJECT ENGINEER.

TABLE

MODEL NO.	HOSE COLOR
QFEMTSCVR-T4LR	GRAY
QFEMTSCVR-T4LRF	YELLOW

KEY		REFERENCES		MATERIALS		QUAARDGUARD ELITE M10 WIDE SYSTEM	
①	BAY ASSEMBLY	SERIAL NO.	EMPRAGRAM	QFEMTSCVR-T4LR	SEE TABLE	BY TENSION STRUT BACKUP AND 4" OFFSET TO SAFETY SHAPE TRANSITION FLARED	
②	FENDER PANEL	SALES ORDER	EMPRAGRAM	QFEMTSCVR-T4LR	SEE TABLE		
③	FENDER PANEL	EM PROJECT	EMPRAGRAM	QFEMTSCVR-T4LR	SEE TABLE		
④	MONORAIL	DESIGN SPEED	EMPRAGRAM	QFEMTSCVR-T4LR	SEE TABLE		
⑤	NOSE ASSEMBLY	NOSE TYPE	EMPRAGRAM	QFEMTSCVR-T4LR	SEE TABLE		
⑥	BACKUP	NO. OF UNITS	EMPRAGRAM	QFEMTSCVR-T4LR	SEE TABLE		

4" Safety Shape Flared Transition QFEMTSCVR-T4LR

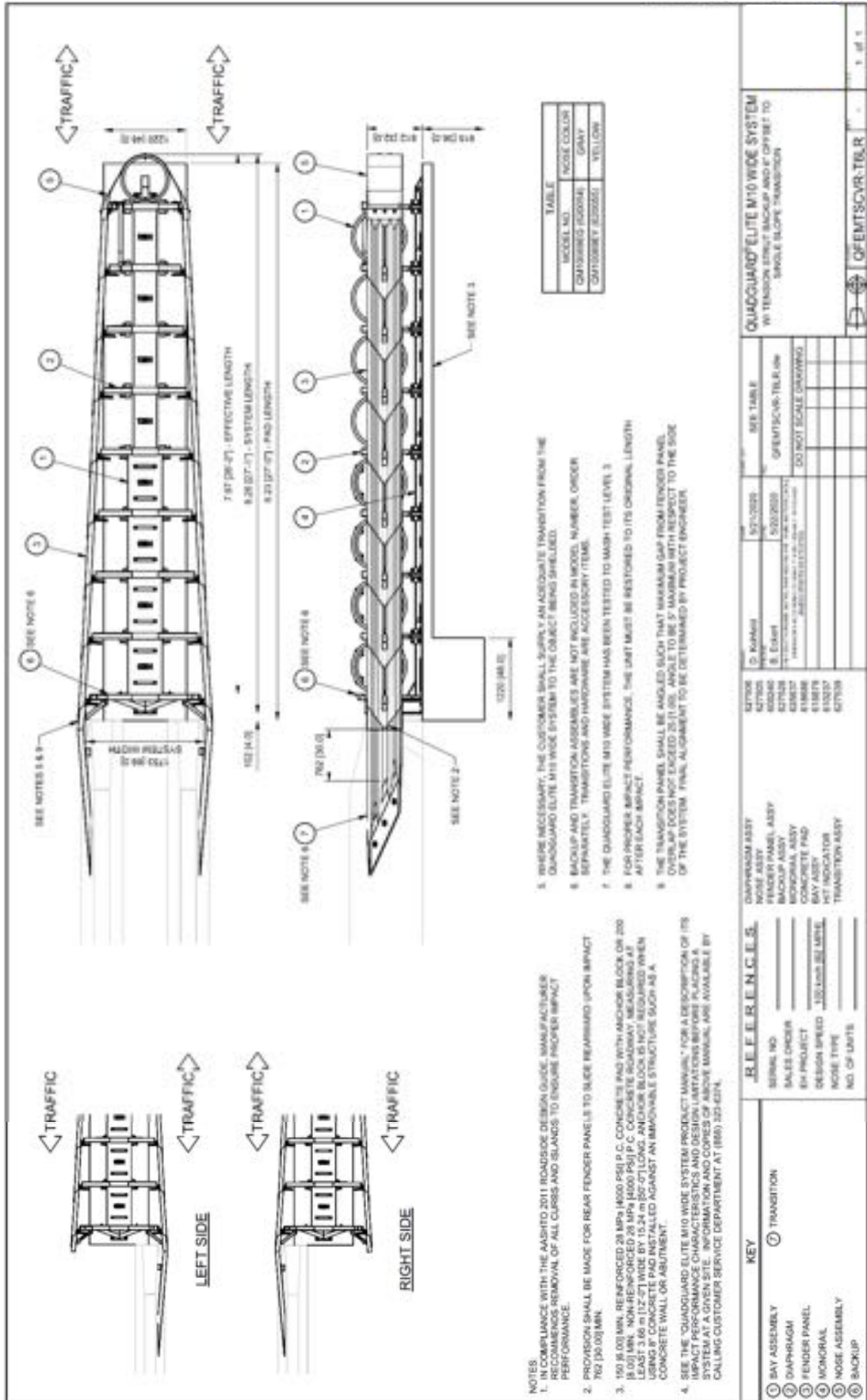

6" Single Slope Transition QFEMTSCVR-T6LR

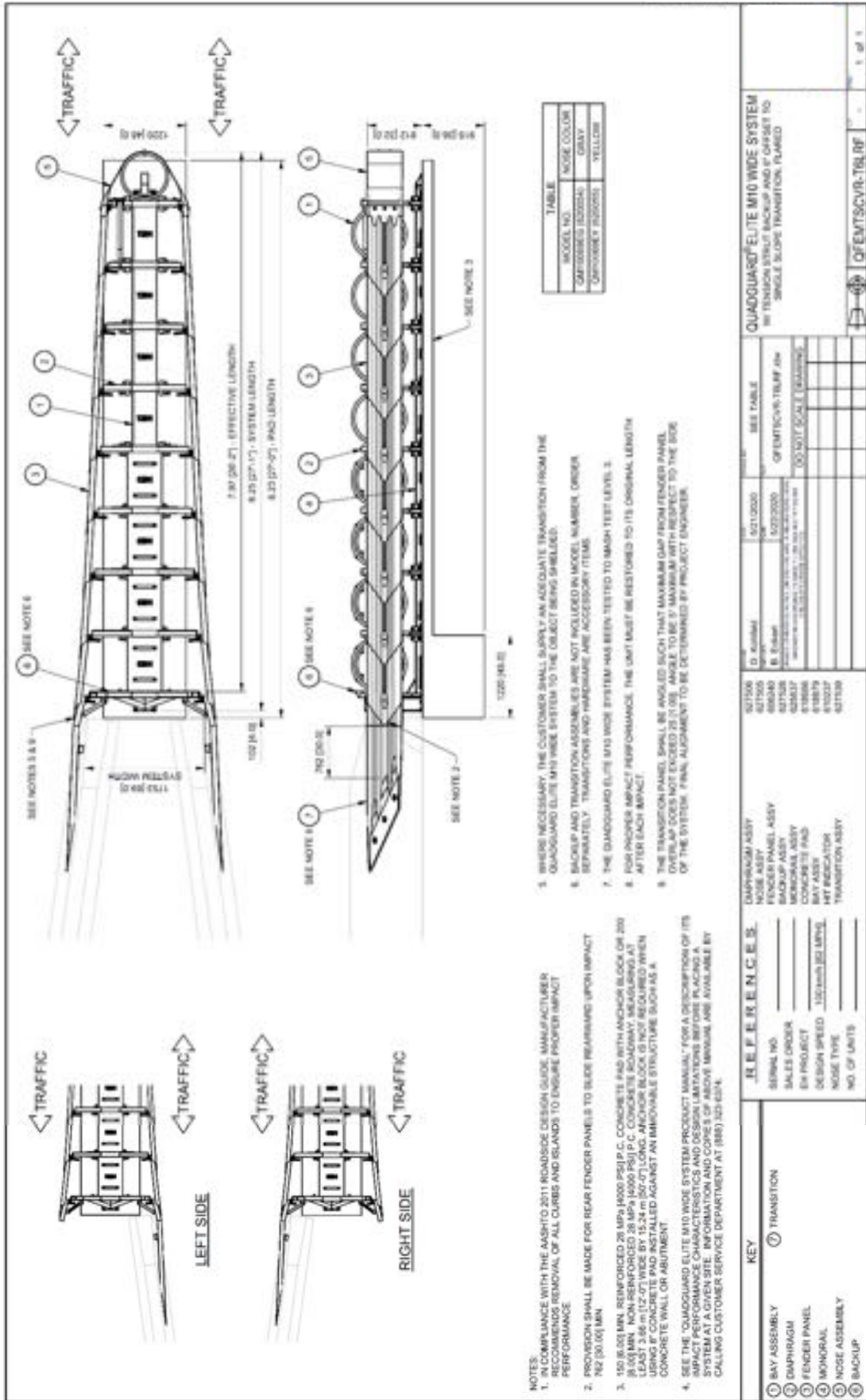

TABLE	
MODEL NO.	NOSE COLOR
CARBON FIBER BOARD	GRAY
CONCRETE FIBERS	YELLOW

- WHERE NECESSARY, THE CUSTOMER SHALL SUPPLY AN ADEQUATE TRANSITION FROM THE QUADGUARD ELITE M10 WIDE SYSTEM TO THE OBJECT BEING PROTECTED.
- BACKUP AND TRANSITION ASSEMBLY ARE NOT INCLUDED IN MODEL NUMBER, ORDER SEPARATELY. TRANSITIONS AND HARDWARE ARE ACCESSORY ITEMS.
- THE QUADGUARD ELITE M10 WIDE SYSTEM HAS BEEN TESTED TO MATCH TEST LEVEL 3.
- FOR IMPACT PERFORMANCE, THE UNIT MUST BE RESTORED TO ITS ORIGINAL LENGTH AFTER EACH IMPACT.
- THE TRANSITION PANEL SHALL BE ANGLED SUCH THAT MAXIMUM GAP FROM FENDER PANEL OVERLAP DOES NOT EXCEED 25 (1.0) INCHES, AND TO BE 5' MAXIMUM WITH RESPECT TO THE SIDE OF THE SYSTEM. FINAL ADJUSTMENT TO BE DETERMINED BY PROJECT ENGINEER.

- IN COMPLIANCE WITH THE AASHTO 2011 ROADSIDE DESIGN GUIDE, MANUFACTURER RECOMMENDS REMOVAL OF ALL CURBS AND ISLANDS TO ENSURE PROPER IMPACT PERFORMANCE.
- PROVISION SHALL BE MADE FOR REAR FENDER PANELS TO SLIDE REARWARD UPON IMPACT.
- 150 (6.0) MIN. REINFORCED 28 MPa (4000 PSI) P.C. CONCRETE PAD WITH ANCHOR BLOCK OR 200 (8.0) MIN. NON-REINFORCED 28 MPa (4000 PSI) P.C. CONCRETE PAD WITH ANCHOR BLOCK. AT ALL TIMES, THE TRANSITION SHALL BE INSTALLED AGAINST AN IMMOVABLE STRUCTURE SUCH AS A CONCRETE WALL OR ABUTMENT.
- SEE THE "QUADGUARD ELITE M10 WIDE SYSTEM PRODUCT MANUAL" FOR A DESCRIPTION OF ITS IMPACT PERFORMANCE CHARACTERISTICS AND DESIGN LIMITATIONS BEFORE PLACING A SYSTEM AT A GIVEN SITE. INFORMATION AND COPIES OF ABOVE MANUAL ARE AVAILABLE BY CALLING CUSTOMER SERVICE DEPARTMENT AT (888) 423-6244.

KEY		REFERENCES	
①	BAY ASSEMBLY	QUADGUARD ELITE M10 WIDE SYSTEM	BY TENSION STRUT BACKUP AND 4" OFFSET NO. SINGLE SLOPE TRANSITION, FLARED
②	DAMPBRAGM		
③	FENDER PANEL		
④	MONORAIL		
⑤	NOSE ASSEMBLY		
⑥	BACKUP		
⑦	TRANSITION		

REV.	DATE	BY	APP'D.	DESCRIPTION
1	07/10/2020	D. KUMAR		ISSUE FOR CONSTRUCTION
2	07/20/2020	B. ELLER		ISSUE FOR CONSTRUCTION
3	08/10/2020			ISSUE FOR CONSTRUCTION
4	08/10/2020			ISSUE FOR CONSTRUCTION
5	08/10/2020			ISSUE FOR CONSTRUCTION
6	08/10/2020			ISSUE FOR CONSTRUCTION
7	08/10/2020			ISSUE FOR CONSTRUCTION
8	08/10/2020			ISSUE FOR CONSTRUCTION
9	08/10/2020			ISSUE FOR CONSTRUCTION
10	08/10/2020			ISSUE FOR CONSTRUCTION

NO.	DESCRIPTION	DATE
1	QUADGUARD ELITE M10 WIDE SYSTEM	07/10/2020
2	BY TENSION STRUT BACKUP AND 4" OFFSET NO. SINGLE SLOPE TRANSITION, FLARED	07/10/2020
3	QUADGUARD ELITE M10 WIDE SYSTEM	07/10/2020
4	BY TENSION STRUT BACKUP AND 4" OFFSET NO. SINGLE SLOPE TRANSITION, FLARED	07/10/2020
5	QUADGUARD ELITE M10 WIDE SYSTEM	07/10/2020
6	BY TENSION STRUT BACKUP AND 4" OFFSET NO. SINGLE SLOPE TRANSITION, FLARED	07/10/2020
7	QUADGUARD ELITE M10 WIDE SYSTEM	07/10/2020
8	BY TENSION STRUT BACKUP AND 4" OFFSET NO. SINGLE SLOPE TRANSITION, FLARED	07/10/2020
9	QUADGUARD ELITE M10 WIDE SYSTEM	07/10/2020
10	BY TENSION STRUT BACKUP AND 4" OFFSET NO. SINGLE SLOPE TRANSITION, FLARED	07/10/2020

6" Single Slope Flared Transition QFEMTSCVR-T6LRF

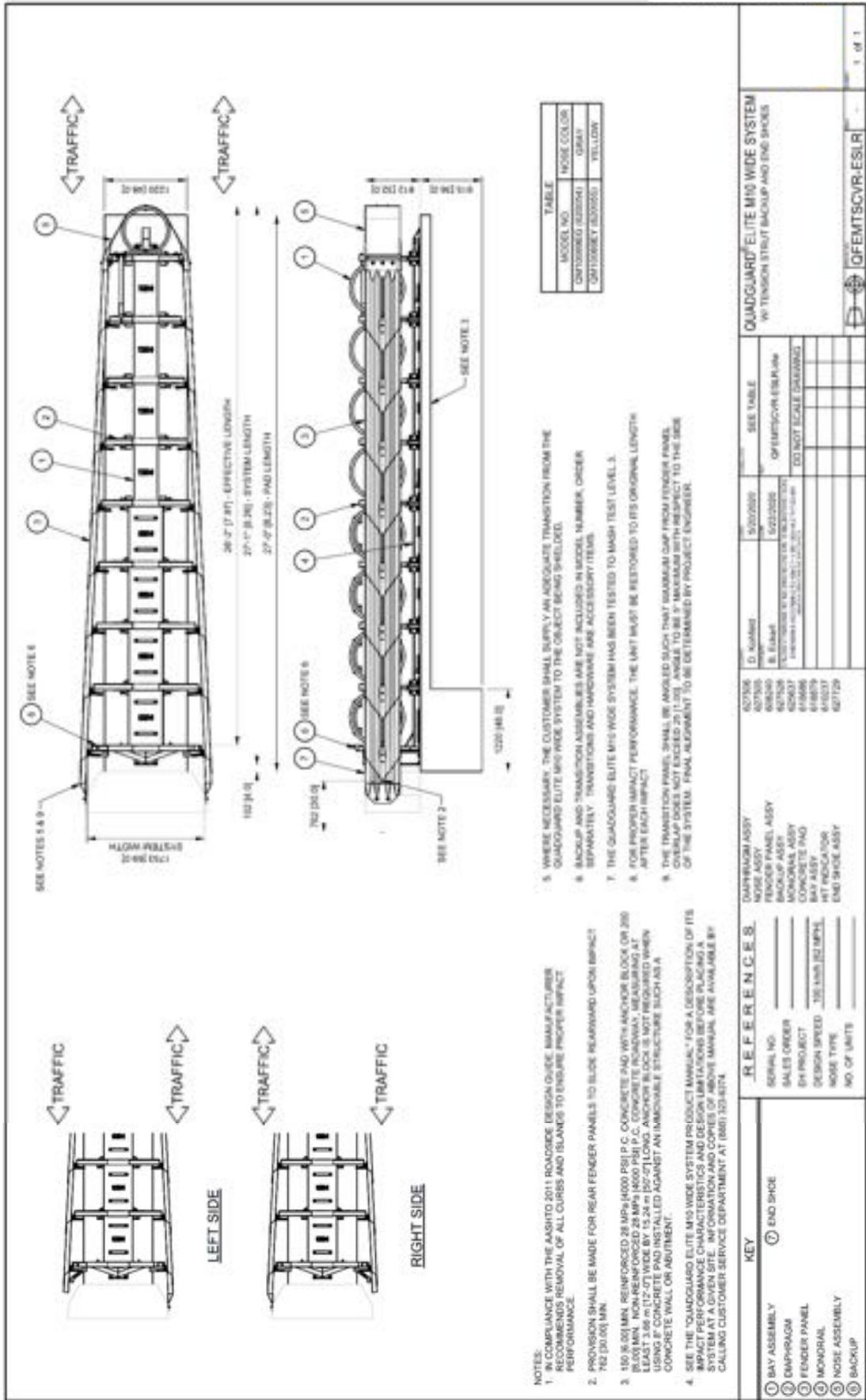

TABLE	
MODEL NO.	NOISE COLOR
QFEMTSCVR-ESLRI	GRAY
QFEMTSCVR-ESLRS	YELLOW

- WHERE NECESSARY, THE CUSTOMER SHALL SUPPLY AN ADEQUATE TRANSITION FROM THE QUADGUARD ELITE M10 WIDE SYSTEM TO THE OBJECT BEING PROTECTED.
- BACKUP AND TRANSITION ASSEMBLIES ARE NOT INCLUDED IN MODEL NUMBER. ORDER SEPARATELY. TRANSITIONS AND HARDWARE ARE ACCESSORY ITEMS.
- THE QUADGUARD ELITE M10 WIDE SYSTEM HAS BEEN TESTED TO WASH TEST LEVEL 3.
- FOR PROPER IMPACT PERFORMANCE, THE UNIT MUST BE RESTORED TO ITS ORIGINAL LENGTH AFTER EACH IMPACT.
- THE TRANSITION PANEL SHALL BE ANGGLED SUCH THAT MAXIMUM GAP FROM FENDER PANEL OVERLAP DOES NOT EXCEED 20 (1.00), AVAILBLE TO BE 3" MAXIMUM WITH RESPECT TO THE SIDE OF THE SYSTEM. FINAL ALIGNMENT TO BE DETERMINED BY PROJECT ENGINEER.

- IN COMPLIANCE WITH THE AASHTO 2011 ROADSIDE DESIGN GUIDE, MANUFACTURER RECOMMENDS REMOVAL OF ALL CURBS AND ISLANDS TO ENSURE PROPER IMPACT PERFORMANCE.
- PROVISION SHALL BE MADE FOR REAR FENDER PANELS TO SLIDE REARWARD UPON IMPACT. 162 (6.40) MIN.
- 150 (6.00) MIN. REINFORCED 28 MPa (4000 PSI) P.C. CONCRETE PAD WITH ANCHOR BLOCK OR 200 (8.00) MIN. NON-REINFORCED 28 MPa (4000 PSI) P.C. CONCRETE ROADWAY. MEASURING AT LEAST 3.06 m (10'-07") WIDE BY 15.24 m (50'-0") LONG. ANCHOR BLOCK IS NOT REQUIRED WHEN USING P.C. CONCRETE PAD INSTALLED AGAINST AN IMMOVABLE STRUCTURE SUCH AS A CONCRETE WALL OR ADJUTMENT.
- SEE THE "QUADGUARD ELITE M10 WIDE SYSTEM PRODUCT MANUAL" FOR A DESCRIPTION OF ITS IMPACT PERFORMANCE CHARACTERISTICS AND DESIGN LIMITATIONS BEFORE PLACING A SYSTEM AT A GIVEN SITE. INFORMATION AND COPIES OF ABOVE MANUAL ARE AVAILABLE BY CALLING CUSTOMER SERVICE DEPARTMENT AT (866) 333-8174.

KEY		REFERENCES	
①	BAY ASSEMBLY	DESIGN NO.	5007020
②	DAMPFRAGM	SALES ORDER	QFEMTSCVR-ESLRI-14
③	FENDER PANEL	EN PROJECT	DO NOT SCALE DRAWING
④	MONORAIL	DESIGN SPEED	105 MPH (52 MPH)
⑤	NOISE ASSEMBLY	NOISE TYPE	
⑥	BACKUP	NO. OF UNITS	

REV.	DESCRIPTION	DATE	BY	APP.	DATE	BY	APP.
01	ISSUE FOR CONSTRUCTION	05/07/2020	D. KAMRAT		05/07/2020		
02	REVISED TO ADD DAMPFRAGM	05/07/2020	B. TAMM		05/07/2020		
03	REVISED TO ADD MONORAIL ASSEMBLY	05/07/2020			05/07/2020		
04	REVISED TO ADD CONCRETE PAD	05/07/2020			05/07/2020		
05	REVISED TO ADD BAY ASSEMBLY	05/07/2020			05/07/2020		
06	REVISED TO ADD END SHOE ASSEMBLY	05/07/2020			05/07/2020		

QUADGUARD ELITE M10 WIDE SYSTEM W/ TENSION STRUT BACKUP AND END SHOES		SEE TABLE	
DAMPFRAGM ASSEMBLY		QFEMTSCVR-ESLRI-14	
BACKUP ASSEMBLY		QFEMTSCVR-ESLRI-14	
MONORAIL ASSEMBLY		QFEMTSCVR-ESLRI-14	
BAY ASSEMBLY		QFEMTSCVR-ESLRI-14	
HT INDICATOR		QFEMTSCVR-ESLRI-14	
END SHOE ASSEMBLY		QFEMTSCVR-ESLRI-14	

End Shoe Transition QFEMTSCVR-ESLR

Notes:

Notes:



For more complete information on Valtir products and services, visit us on the web at www.valtir.com. Materials and specifications are subject to change without notice. Please contact Valtir to confirm that you are referring to the most current instructions.

WWW.VALTIR.COM
1.888.323.6374